

**TOYOTA
INDUSTRIAL
VEHICLE**

PARTS CATALOG

FBA30

No.G210-1

**TOYOTA MOTOR CORPORATION
TOYODA AUTOMATIC LOOM WORKS, LTD.**

TOYOTA

FORKLIFT TRUCK

PARTS CATALOG

MODEL	F B A 3 0	
FRAME NO.	F B A 3 0	
LIFTING HEIGHT	_____	mm

DESCRIPTION

UL-approved Model Type E	
UL-approved Model Type EE	
Cold Storage Model Type 45S	
Deadman Seat Brake	
Fully Oil Charged Lift Cylinder	

TOYOTA MOTOR CORPORATION
TOYODA AUTOMATIC LOOM WORKS, LTD.

QUICK REFERENCE INDEX	
INTRODUCTION	
ELECTRICAL SYSTEM	
CHASSIS	
BODY	
ELECTRICAL SYSTEM	
MAST	
HYDRAULIC SYSTEM	

GENERAL INFORMATION

This parts catalog has been prepared for the customers of Toyota Industrial Vehicles and this shows only the part name codes instead of parts numbers.

When ordering parts from your local Toyota dealer, please specify the complete model number of the truck, the engine number or frame number. Also it is essential that you specify the part name codes described in the pages of illustrations and text.

The complete model number and frame number are shown in the front page of this catalog. All the columns in this quick reference index are supposed to be filled out by both the factory and your local dealer.

For the industrial vehicle with optional equipment, which is described in the lower part of the DESCRIPTION, it is imperative for you to specify optional equipment when ordering parts.

Your Toyota dealer has always been furnished with enough information to decode the correct part numbers based on your information of model number, engine number or frame number as well as part name code.

INFORMATIONS D'ORDRE GENERAL

Ce catalogue de pièces a été préparé pour les propriétaires de Véhicules Industriels Toyota. On n'y trouvera que les codes de désignation de pièces au lieu des numéros de pièces.

Pour la commande de pièces auprès de votre concessionnaire Toyota, prière de spécifier le numéro de modèle complet de l'engin, le numéro du moteur ou le numéro du châssis. Il est aussi nécessaire de spécifier les codes de désignation de pièces comme ils sont décrits dans les pages d'illustrations et dans le texte.

Le numéro de modèle complet et le numéro de châssis sont indiqués en première page de ce catalogue. Toutes les colonnes de l'index de référence rapide devraient être remplies par l'usine et par votre concessionnaire.

Pour le véhicule industriel avec équipement optionnel, décrit en bas de page sous la rubrique "DESCRIPTION", il convient de bien spécifier qu'il s'agit de cet équipement lors de commande de pièces.

Votre concessionnaire Toyota est toujours suffisamment informé pour décoder les numéros de pièces sur la base de votre information du numéro de modèle, du numéro de moteur ou de châssis, et des codes de désignation de pièces.

INFORMACION GENERAL

Este catálogo de piezas ha sido preparado para los clientes de vehículos industriales de TOYOTA, e incluye tan sólo los códigos de nombre de pieza en lugar de los números de pieza.

Cuando solicite piezas a su distribuidor local de TOYOTA especifique por favor el número de modelo completo del vehículo, el número de motor o el número de bastidor. Asimismo, es esencial que Ud. especifique los códigos de nombre de pieza descritos en las páginas de ilustraciones y de texto.

El número completo de modelo y el número de bastidor se indican en la portada de este catálogo. Se supone que todas las columnas de este índice de referencia se han rellenado, tanto por parte de la fábrica como por parte de su distribuidor local.

En lo que concierne a los vehículos industriales con equipos opcionales, que se describen en la parte baja de la DESCRIPCION, es absolutamente necesario que especifique equipos opcionales cuando solicite piezas de repuesto.

Su distribuidor local de TOYOTA posee la información necesaria para descifrar los números correctos de cada pieza a base de su información de número de modelo, número de motor o número de bastidor, así como el código de nombre de la pieza.

ALLGEMEINE INFORMATION

Dieser Teilkatalog wurde für die Benutzer von Toyota Industriefahrzeugen zusammengestellt und zeigt anstelle von Teilenummern nur die Teilennamen-Kodes.

Geben Sie bei Teilebestellungen von Ihrem Toyota-Händler am Platz bitte die vollständige Modellnummer des Fahrzeugs, die Motornummer oder Fahrgestellnummer an. Es ist auch erforderlich, daß Sie die in den Illustrationen und im Text beschriebenen Teilennamen-Kodes angeben.

Die vollständige Modellnummer und Fahrgestellnummer finden Sie auf der Vorderseite dieses Katalogs. Alle Spalten in dieser Bezugsabelle sollen sowohl vom Werk als von Ihrem Händler am Platz ausgefüllt werden.

Für Industriefahrzeuge mit Sonderausrüstung, welche im unteren Teil der BESCHREIBUNG erläutert ist, müssen Sie bei der Bestellung von Teilen unbedingt diesbezügliche Angaben machen.

Ihr Toyota-Händler verfügt stets über genügend Information, um die richtigen Teilenummern zu entschlüsseln, basiert auf Ihren Angaben zu Modellnummer, Motornummer oder Fahrgestellnummer und den Teilennamen-Kodes.

ILLUSTRATION ET COMPOSITION DU DE TEXTE DE CODE DE DESIGNATION DE PIECE

Une (1) page contiendra essentiellement une illustration et ses codes de désignation de pièce. Toutefois, lorsque l'espace réservé au texte est insuffisant, la continuation se trouvera sur la page suivante.



ABBILDUNG UND TEXTSEITENAUFBAU FÜR TEILENAMEN-KODE

Grundsätzlich finden Sie auf einer (1) Seite sowohl die Abbildung als auch den Teilnamen-Kode.

Wenn für den Text jedoch nicht genügend Platz vorhanden ist, wird er auf der nächsten Seite fortgesetzt.

- **Numéro de figure**
Ce catalogue de pièces a été préparé en fonction des numéros de figures.
- **Titre de figure**
Une désignation de pièce représentative, celle d'une pièce d'un ensemble important, est indiquée comme titre de figure de l'illustration.
- **Sous-titre**
La désignation optionnelle ou les spécifications spéciales de chaque illustration sont indiquées.
- **Code de désignation de pièce**
Obtenu en combinant le numéro de figure et les codes des illustrations inhérents à chaque pièce. Ce code permettra à votre concessionnaire Toyota de trouver les numéros de pièces corrects.
- **Désignation de pièce**
La désignation de la pièce est indiquée pour chacun des codes de désignation de pièce.
- **Q'ty (quantité)**
La colonne quantité indique les pièces utilisées de l'unité de code de désignation de pièce. La quantité maximum est indiquée quand la quantité utilisée diffère pour chacun des véhicules. Quand la quantité de pièces utilisées diffère ou lorsqu'elle dépasse 100 pièces, la quantité 99 est indiquée.
- **Numéros de pièces standard**
Les pièces standard comme les boulons, les écrous, les rondelles, etc. sont décrits dans les numéros de pièces. Pour commander ces pièces, priez de spécifier les numéros de pièces.

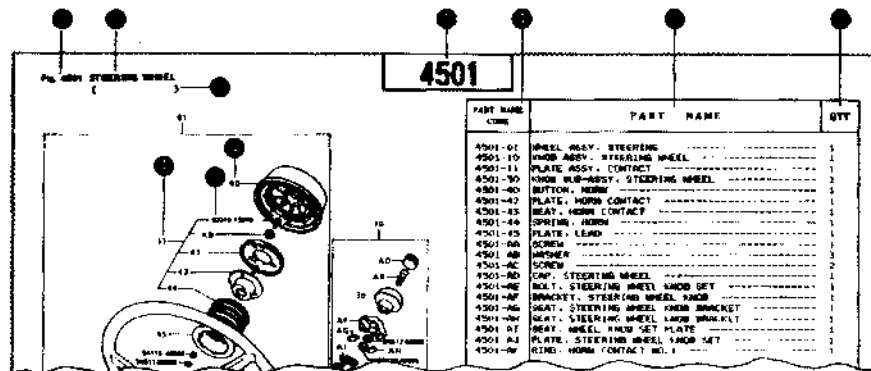
- **Abbildungsnummer**
Dieser Teilekatalog wurde nach Abbildungsnummern zusammengestellt.
- **Abbildungstitel**
Ein stellvertretender Teilname, welcher zugleich die Bezeichnung für die Hauptbaugruppe ist, wird als Abbildungstitel der Illustration angegeben.
- **Untertitel**
Ein zusätzlicher Name oder eine besondere Kennzeichnung werden für jede Illustration angegeben.
- **Teilnamen-Kode**
Dies ist eine Kombination von ziffern und Abbildungskodes, die jedes Teil betreffen. Es ist ein Schlüssel für Ihren Toyota-Händler, um die richtigen Teilenummern zu finden.
- **Teilname**
Grundsätzlich wird der Teilname für alle Teilnamen-Kodes angegeben.
- **QTY (Menge)**
Die Mengenspalte gibt die benutzte Stückzahl von Teilnamen-Kode-Einheiten an.
Wenn die benutzte Stückzahl je nach Fahrzeug Verschieden ist, wird die Höchstmenge angegeben.
Wenn die benutzte Menge 100 Stück überschreiten kann, wird als Menge 99 angegeben.
- **Standardteile-Nummern**
Die Standardteile, wie Schrauben, Muttern, Unterlegscheiben usw., sind in den Teilenummern beschrieben. Geben Sie bei Bestellung dieser Teile die Teilenummern an.

ILLUSTRATION AND PART NAME CODE TEXT PAGE COMPOSITION

Essentially, one (1) page will present both the illustration and part name code. However, when the space for text page is not enough the next page will be used in succession.

COMPOSICION DE LAS PAGINAS DE ILUSTRACIONES Y DE TEXTO DE CODIGOS DE NOMBRE DE PIEZAS

Básicamente, una (1) página incluirá tanto la ilustración como el código de nombre de la pieza.

No obstante, si el espacio no fuese suficiente, se utilizará la página siguiente.

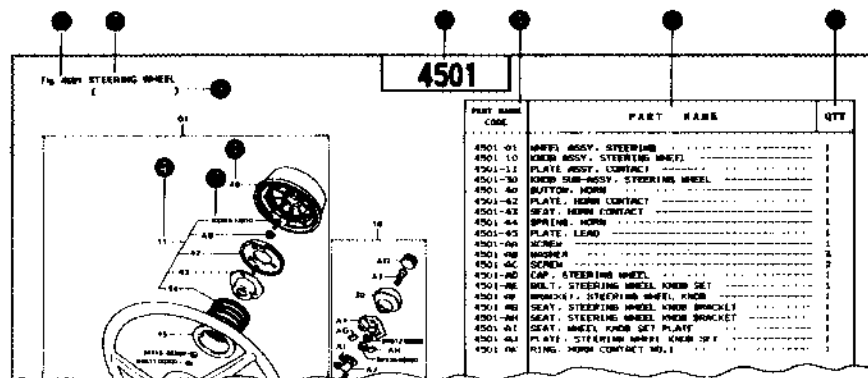

1. **Figure number**
This parts catalog has been prepared according to the figure numbers.
2. **Figure title**
A representative part name which is the major assembly part name is shown as the figure title of the illustration.
3. **Sub title**
The optional name or special specification of each illustration are indicated.
4. **Part name code**
This is a combination of figure number and codes of illustrations pertaining to each part. This is a key for your Toyota dealer to find the correct part numbers.
5. **Part name**
As a rule, the part name is indicated for each of the part name codes.
6. **QTY (Quantity)**
The quantity column indicates the utilized pieces of part name code unit. When the utilized quantity changes according to each of the vehicles, maximum is indicated. When the utilized quantity of the parts differs or is more than 100 pieces, quantity 99 is indicated.
7. **Standard parts numbers**
The standard parts such as the bolts, nuts, washer, etc. are described with parts numbers. When ordering these parts, specify parts numbers.

1. **Número de figura**
Este catálogo de piezas se ha preparado de acuerdo con los números de las figuras.
2. **Título de las figuras**
Como título de las figuras de la página de ilustraciones, se incluye un nombre que sea representativo del nombre del mayor conjunto.
3. **Subtítulo**
Se indican el nombre opcional o las especificaciones especiales de cada ilustración.
4. **Código de nombre de pieza**
Se trata de una combinación de número de figura y de código de las ilustraciones correspondientes a cada pieza. Esta es la clave para que su distribuidor local de TOYOTA pueda encontrar el número de pieza correcto.
5. **Nombre de la pieza**
Como norma, se indica el nombre de cada uno de los códigos de nombre de pieza.
6. **QTY (Cantidad)**
La columna de cantidad indica el número de piezas utilizadas de cada unidad de código de nombre de pieza. Cuando la cantidad utilizada es intercambiable entre cada uno de los vehículos, se indica el máximo. Cuando la cantidad de piezas utilizadas pueda diferir o ser superior a 100, se indica como cantidad 99.
7. **Números de piezas normalizadas**
Las piezas corrientes, tales como pernos, tuercas, arandelas etc., se describen con número de pieza. Cuando solicite tales piezas, indique su número de pieza.

DATA PLATE & SERIAL NUMBERS

For retrieving correct part numbers, it's indispensable to know the truck model, as well as frame number (or engine number).
Customers can obtain said information in the data plate on the truck or in this user parts catalog.

PLAQUE DE DONNEES TECHNIQUES & NUMEROS DE SERIE

Pour relever correctement le numéro des pièces, il est indispensable de connaître le modèle de l'engin, ainsi que le numéro du châssis (ou du moteur).
Les propriétaires peuvent trouver ladite information sur la plaque de données techniques de l'engin ou dans le présent ouvrage.

PLACA DE DATOS Y NUMEROS DE SERIE

Para obtener los números de pieza correctos, es indispensable conocer el modelo del vehículo, así como el número del bastidor (o del motor).
Los clientes pueden obtener dicha información por la placa de datos del vehículo o este catálogo de piezas para el usuario.

DATENPLATTE & SERIENNUMMERN

Um die richtige Teilenummer zu ermitteln, müssen unbedingt das Fahrzeugmodell sowie die Fahrgestellnummer (oder die Motornummer) bekannt sein.
Kunden können diese Angaben von der Datenplatte am Fahrzeug oder in diesem Teilkatalog für Benutzer entnehmen.

Data plate
Placa de datos
Plaque de données techniques
Datenplatte

	
TOYOTA LIFT TRUCK	
MODEL	<input type="text"/>
CODE NO. OF SPECIAL MODEL	<input type="text"/>
MODEL OF ATTACHMENT	<input type="text"/>
VOLTAGE	<input type="text"/>
FRAME NO.	<input type="text"/>
LIFTING HEIGHT	<input type="text"/>
CAPACITY	<input type="text"/>
WEIGHT	<input type="text"/>
PROD. YEAR	<input type="text"/>
TOYODA AUTOMATIC LOOM WORKS. LTD. KARIYA JAPAN	

Data plate
Placa de datos
Plaque de données techniques
Datenplatte

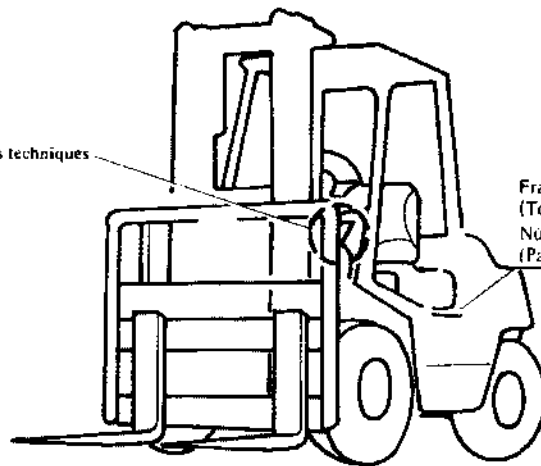

Frame Number
(Top of the frame)
Número de bastidor
(Parte superior del bastidor)

Número de châssis
(haut du châssis)
Fahrgestellnummer
(Oben am Fahrgestell)

FIG. INDEX







<p>FIG. 1401</p> <p>1</p>  <p>ドライブ モーター Drive Motor</p>	<p>FIG. 1402</p> <p>2</p>  <p>ポンプドライブ モーター Pump Drive Motor</p>	<p>FIG. 1403</p> <p>3</p>  <p>P/S ポンプドライブ モーター P/S Pump Drive Motor</p>	<p>FIG. 2401</p> <p>4</p>  <p>コントロール パネル Control Panel</p>	<p>FIG. 2402</p> <p>5</p>  <p>コンタクト パネル Contactor Panel</p>	<p>FIG. 2403</p> <p>6</p>  <p>コンタクト アッセンブリ Contactor Assy</p>	<p>FIG. 2413</p> <p>7</p>  <p>サーキット ブレーカー Circuit Breaker</p>	
<p>電気的 グループ ELECTRICAL GROUP</p>							<p>FIG. 2501</p> <p>8</p>  <p>バッテリー Battery</p>
							<p>FIG. 2512</p> <p>9</p>  <p>バッテリー セパレート チャージャー Battery Separate Charger</p>
							<p>FIG. 2611</p> <p>9</p>  <p>アクセルレータ Accelerator</p>

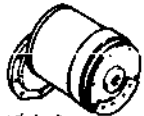

FIG. INDEX

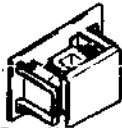
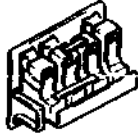

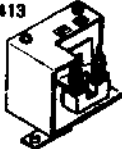
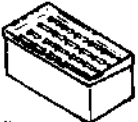
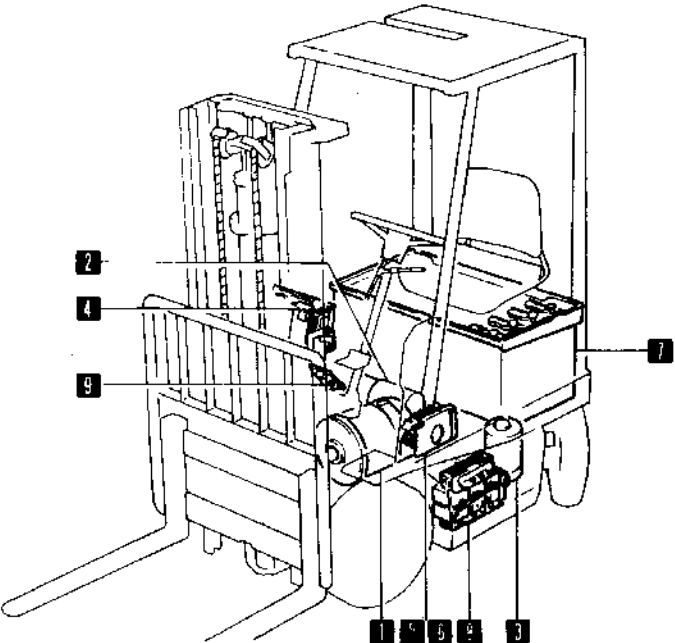











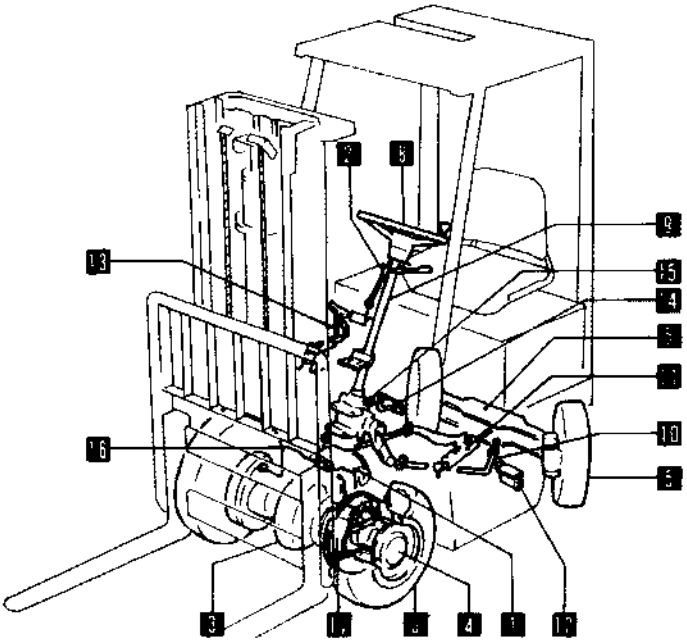

<p>FIG. 3305</p>  <p>ギヤケースとギヤ Gear Case & Gear</p>	<p>FIG. 3310</p>  <p>チェンジレバー Change Lever</p>	<p>FIG. 4101</p>  <p>ディファレンシャル Differential</p>	<p>FIG. 4201</p>  <p>フロントアクセルシャフト Front Axle Shaft</p>	<p>FIG. 4301</p>  <p>リアアクセルタイロッド Rear Axle & Tie-Rod</p>	<p>FIG. 4401</p>  <p>フロントホイールとタイヤ Front Wheel & Tire</p>	<p>FIG. 4402</p>  <p>フロントホイールとタイヤ(ダブル) Front Wheel & Tire (Double)</p>	
<p>シャシ グループ CHASSIS GROUP</p> 							<p>FIG. 4403</p>  <p>リアホイールとタイヤ Rear Wheel & Tire</p>
							<p>FIG. 4501</p>  <p>ステアリングホイール Steering Wheel</p>
							<p>FIG. 4502</p>  <p>ステアリングポスト Steering Post</p>
							<p>FIG. 4507</p>  <p>ドラッグリンクとパイピング Draglink & Steering Piping</p>
<p>FIG. 4715</p>  <p>ドラムブレーキ Drum Brake</p>	<p>FIG. 4714</p>  <p>ブレーキパイプ Brake Pipe</p>	<p>FIG. 4702</p>  <p>ブレーキマスターシリンダ Brake Master Cylinder</p>	<p>FIG. 4701</p>  <p>ブレーキペダル Brake Pedal</p>	<p>FIG. 4601</p>  <p>パーキングブレーキ Parking Brake</p>	<p>FIG. 4510</p>  <p>ステアリングオイルポンプ Steering Oil Pump</p>	<p>FIG. 4508</p>  <p>ステアリングパワーシリンダ Steering Power Cylinder</p>	

FIG. INDEX

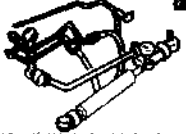



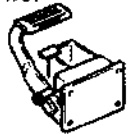

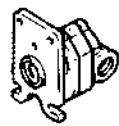
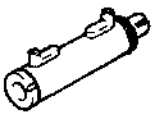



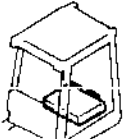

<p>FIG. 5101</p>  <p>フレームトウエイト Frame & Weight</p>	<p>FIG. 5201</p>  <p>フードトヒンジ Hood & Hinge</p>	<p>FIG. 5301</p>  <p>インストールメント パネル ト フロア Instrument Panel & Floor</p>	<p>FIG. 5308</p>  <p>ドライバーシート Driver Seat</p>	<p>FIG. 5401</p>  <p>ヘッドガードトアクセサリ Head Guard & Accessory</p>	<p>FIG. 5406</p>  <p>インジケータプレート Indicator Plate</p>	<p>FIG. 5502</p>  <p>キャンバスキャビントフロントガラス Canvas Cabin & Front Glass</p>	
<p>ボデー、エレクトリカル グループ BODY, ELECTRICAL GROUP</p>							
							
						<p>FIG. 5602</p>  <p>ワイヤリングトクランプ Wiring & Clamp</p>	<p>FIG. 5611</p>  <p>ランプ Lamp</p> <p>FIG. 5612</p>  <p>ランプ ブラケット Lamp Bracket</p> <p>FIG. 5702</p>  <p>メータトスイッチ Meter & Switch</p> <p>FIG. 5801</p>  <p>ワイパーモータトブレード Wiper Motor & Blade</p> <p>FIG. 5706</p>  <p>スピードメータトスピードアラーム Speedo Meter & Speed Alarm</p>

FIG. INDEX

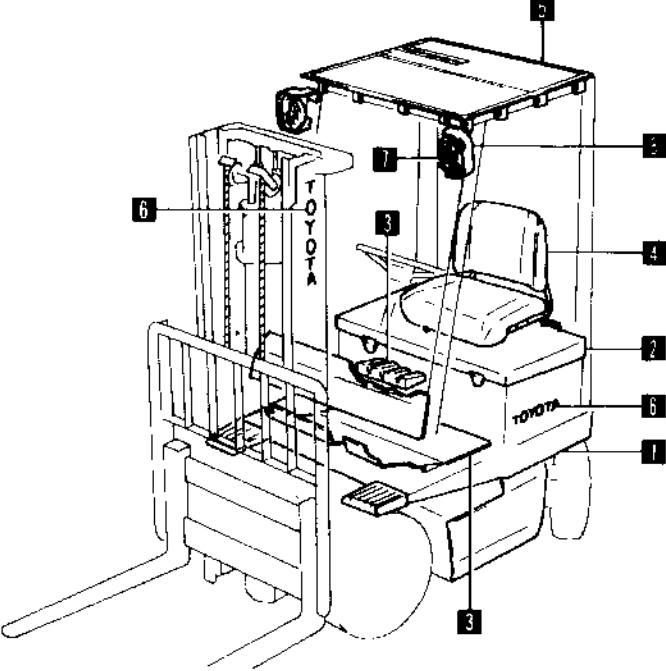







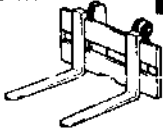

<p>FIG. 6101 1</p>  <p>マスト Mast</p>	<p>FIG. 6301 2</p>  <p>リフト ブラケットフォーク Lift Bracket & Fork</p>	<p>FIG. 6302 3</p>  <p>チェーン & チェーンホイール Chain & Chain Wheel</p>	<p>FIG. 6501 (SV, V) 4</p>  <p>リフト シリンダ Lift Cylinder</p>	<p>FIG. 6502 (FV, FSV) 4</p>  <p>フロント リフト シリンダ Front Lift Cylinder</p>	<p>FIG. 6503 (FV, FSV) 4</p>  <p>リア リフト シリンダ Rear Lift Cylinder</p>	<p>FIG. 6504 (M) 5</p>  <p>リフト シリンダ Lift Cylinder</p>	
<p>マスト ハイドロリック コンポーネント グループ MAST, HYDRAULIC COMPONENT GROUP</p> 							<p>FIG. 6505 (F, FS) 5</p>  <p>フロント リフト シリンダ Front Lift Cylinder</p>
							<p>FIG. 6506 (F, FS) 5</p>  <p>リア リフト シリンダ Rear Lift Cylinder</p>
							<p>FIG. 6511 6</p>  <p>ティルト シリンダ Tilt Cylinder</p>
							<p>FIG. 6701 7</p>  <p>オイル ポンプ Oil Pump</p>
				<p>FIG. 6802 8</p>  <p>マスト パイピング Mast Piping</p>	<p>FIG. 6801 8</p>  <p>ボディ パイピング Body Piping</p>	<p>FIG. 6708 8</p>  <p>オイルコントロールバルブリンク Oil Control Valve Link</p>	<p>FIG. 6705 8</p>  <p>オイルコントロールバルブ Oil Control Valve</p>

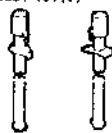
FIG. 0901 STANDARD TOOL

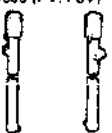
0901

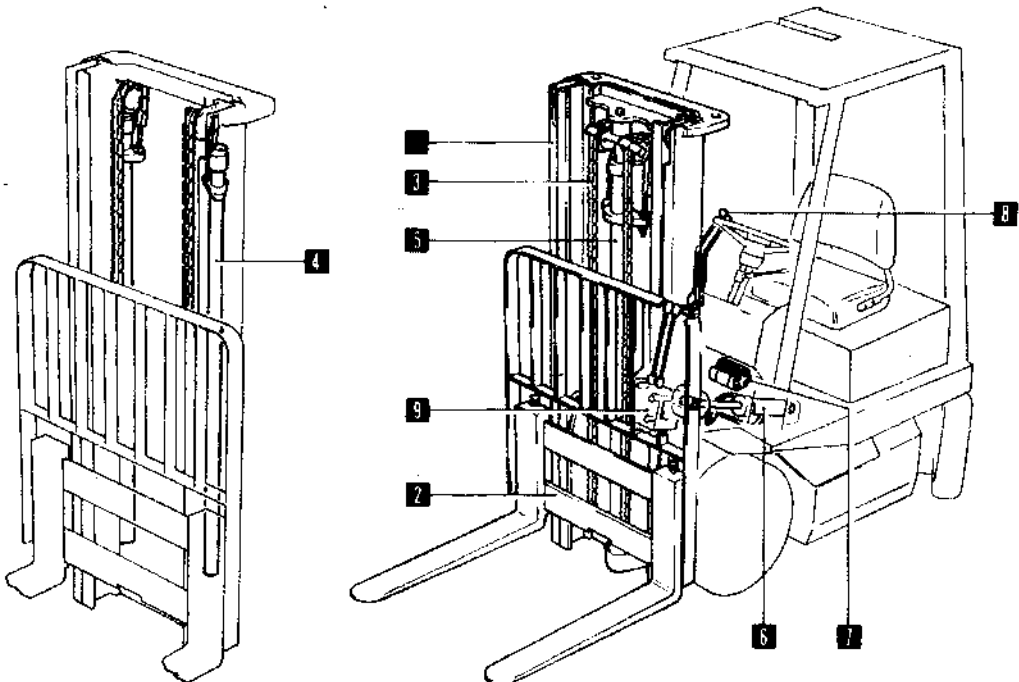
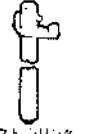
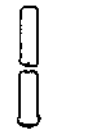

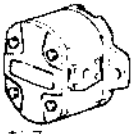
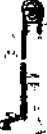
0901 010

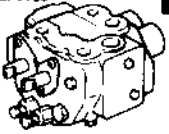
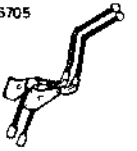
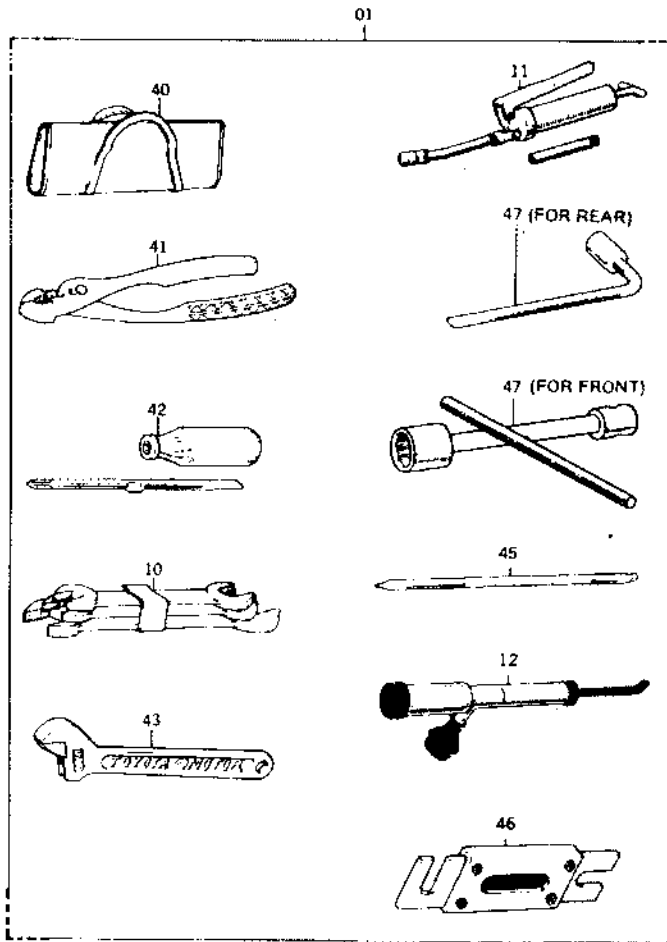
PART NAME CODE	PART NAME	QTY
0901-01	TOOL SET, STANDARD -----	1
0901-10	SPANNER SET -----	1
0901-11	PUMP ASSY, GREASE -----	1
0901-12	METER ASSY, HYDRAULIC SAILING -----	1
0901-40	BAG, TOOL -----	1
0901-41	PRIERS -----	1
0901-42	DRIVER, SCREW -----	1
0901-43	WRENCH, MONKEY -----	1
0901-45	ROD, THERMOMETER -----	1
0901-46	FUSE -----	1
0901-47	WRENCH, HUB NUT BOX -----	1

(MAIN) (1)

G210

FIG. 1401 DRIVE MOTOR

1401

(UL-E)

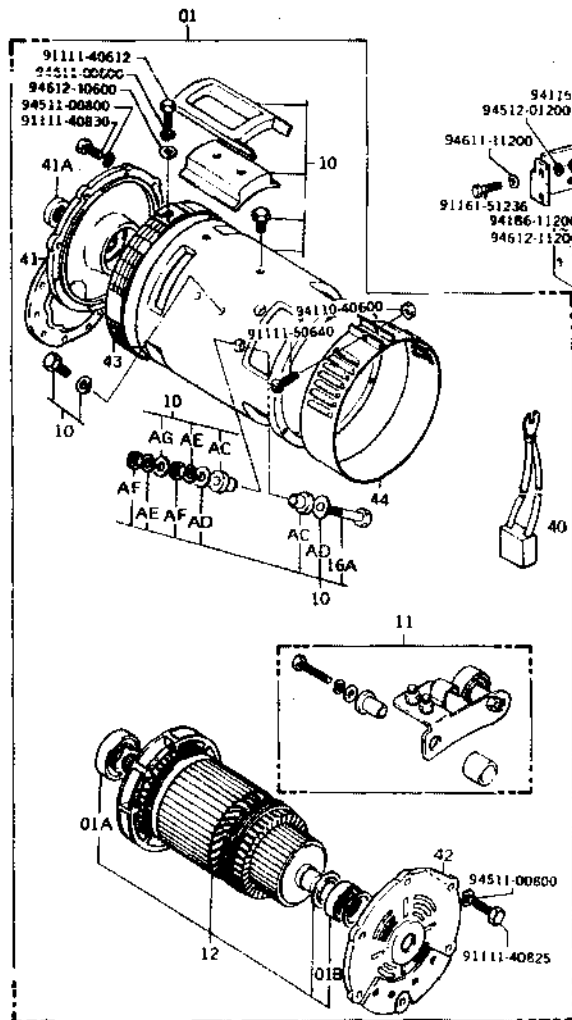

1401-010

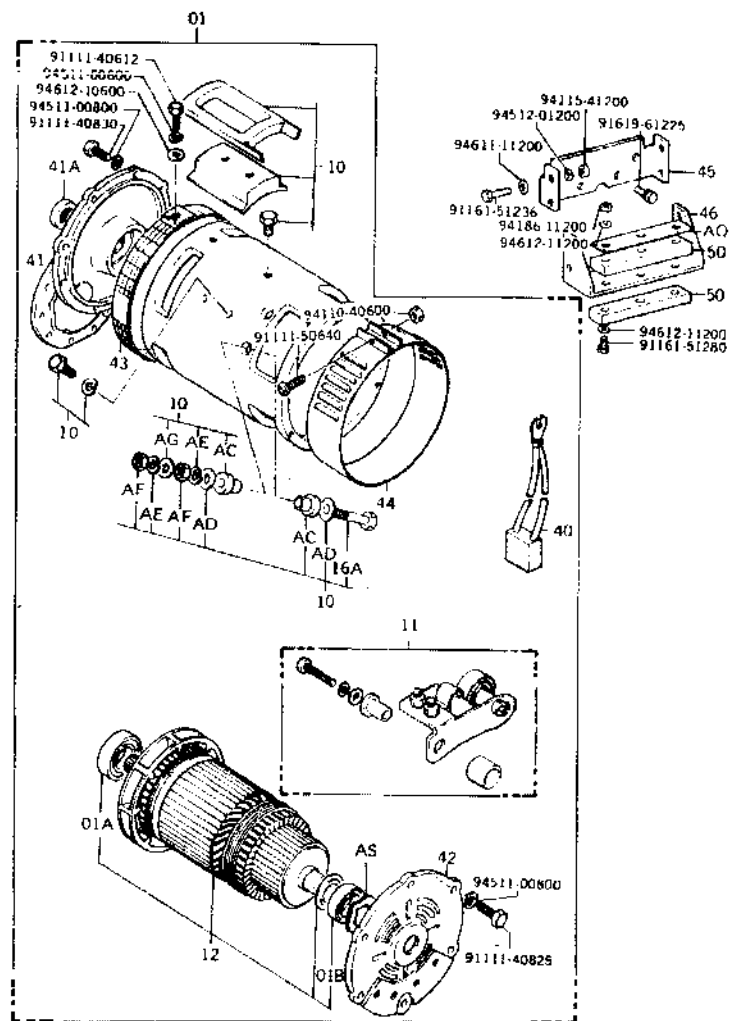

1401-011

FIG. 1401 DRIVE MOTOR

1401

(UL-EE)

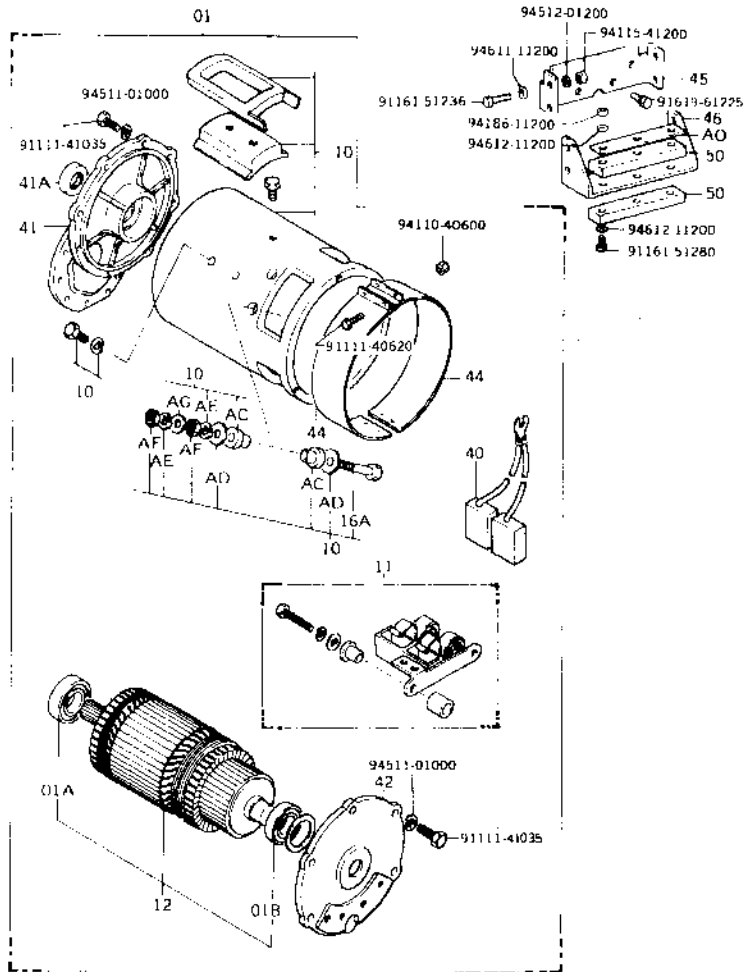

PART NAME CODE	PART NAME	QTY
1401-01	MOTOR ASSY, DRIVE -----	1
1401-01A	BEARING, DRIVE MOTOR, NO.1 -----	1
1401-01B	BEARING, DRIVE MOTOR, NO.2 -----	1
1401-10	YOKE ASSY -----	1
1401-11	HOLDER ASSY, BRUSH -----	4
1401-12	ARMATURE ASSY, DRIVE -----	1
1401-16A	BOLT, STUD (TERMINAL) -----	1
1401-40	BRUSH, DRIVE MOTOR -----	4
1401-41	BRACKET, NO.1 -----	1
1401-41A	SEAL, OIL (FOR BRACKET) -----	1
1401-42	BRACKET, NO.2 -----	1
1401-43	COVER, MOTOR -----	1
1401-44	COVER, BRUSH -----	1
1401-45	BRACKET, DRIVE MOTOR MOUNTING, NO.1 -----	1
1401-46	BRACKET, DRIVE MOTOR MOUNTING, NO.2 -----	1
1401-50	RUBBER, CUSHION (FOR MOTOR MOUNTING) -----	2
1401-AC	INSULATOR -----	8
1401-AD	WASHER, PLATE -----	8
1401-AE	WASHER, SPRING -----	8
1401-AF	NUT -----	8
1401-AG	WASHER, PLATE -----	4
1401-AQ	PLATE, CUSHION RUBBER -----	1
1401-AS	WASHER, WAVE -----	1

FIG. 1402 PUMP MOTOR

1402

(UL-E)

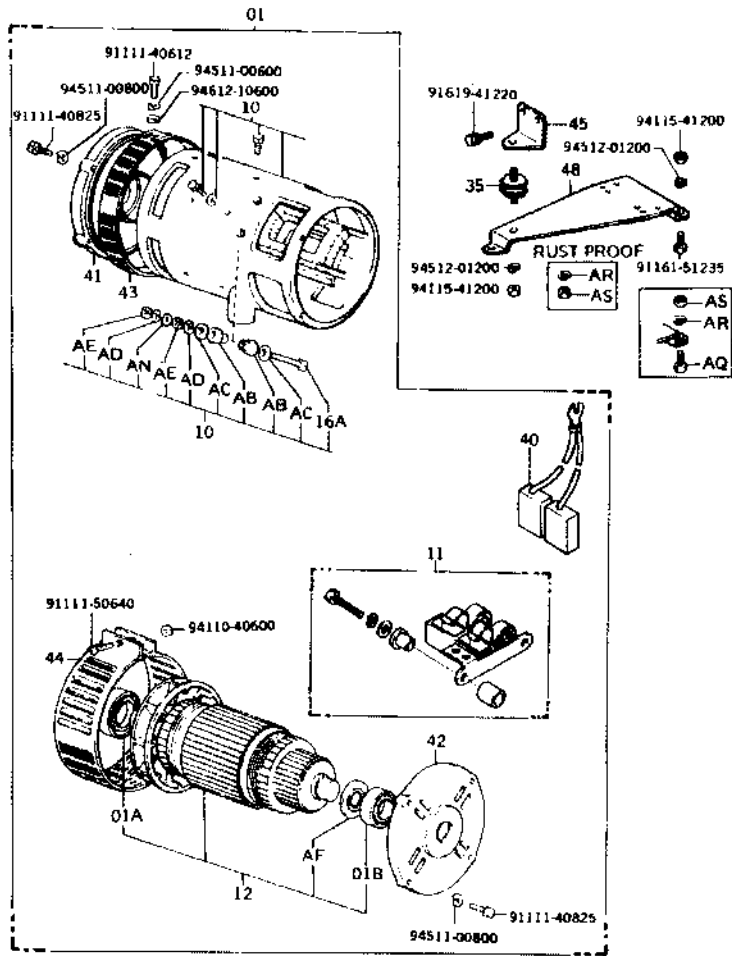

1402-031

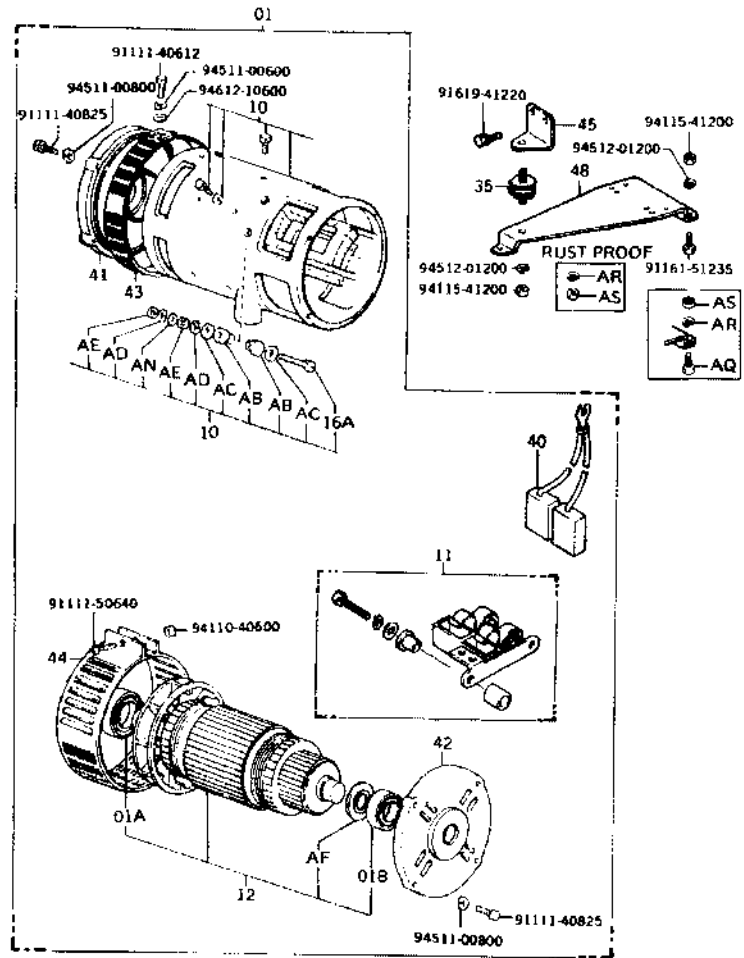

1402-031

FIG. 1402 PUMP MOTOR

1402

(UL-EE)

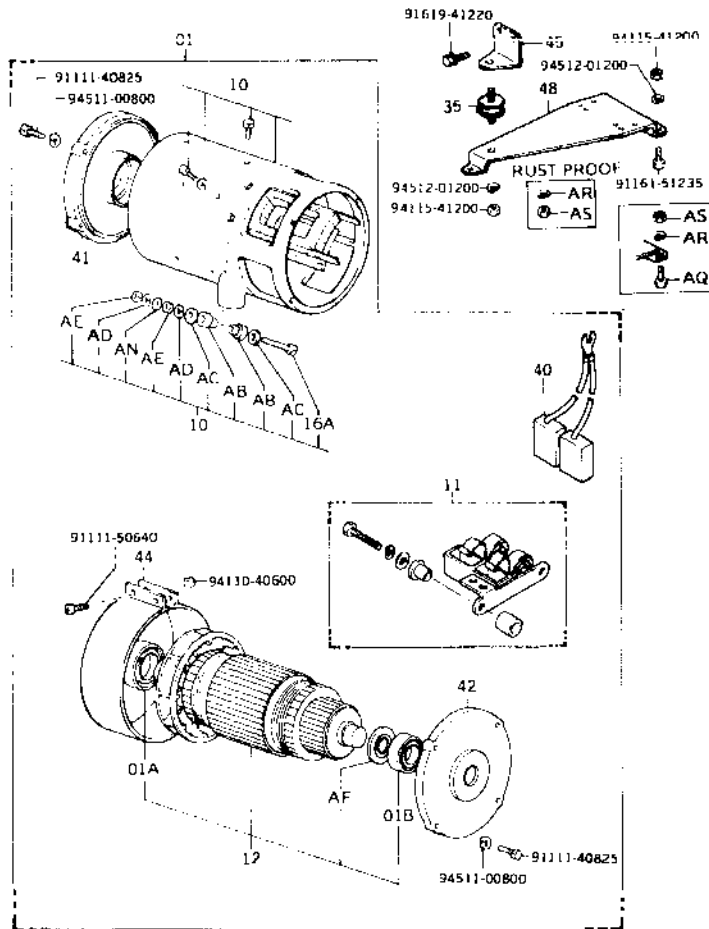

1402-032 A

PART NAME CODE	PART NAME	QTY
1402-01	MOTOR ASSY, PUMP	1
1402-01A	BEARING, PUMP MOTOR, NO.1	1
1402-01B	BEARING, PUMP MOTOR, NO.2	1
1402-10	YUKE ASSY, PUMP MOTOR	1
1402-11	HOLDER ASSY, BRUSH	4
1402-12	ARMATURE ASSY, PUMP MOTOR	1
1402-16A	BOLT, STUD (TERMINAL)	1
1402-35	INSULATOR SUB-ASSY, MOTOR MOUNTING	3
1402-40	BRUSH, PUMP MOTOR	4
1402-41	BRACKET, NO.1	1
1402-42	BRACKET, NO.2	1
1402-43	COVER, MOTOR	1
1402-44	COVER, BRUSH	1
1402-45	BRACKET, PUMP MOTOR MOUNTING	1
1402-48	PLATE, PUMP MOTOR SET	1
1402-AB	INSULATOR	4
1402-AC	WASHER, PLATE	4
1402-AD	WASHER, SPRING	4
1402-AE	NUT	4
1402-AN	WASHER, PLATE	2
1402-AQ	BOLT	3
1402-AR	WASHER, SPRING	7
1402-AS	NUT	7

(MAIN) (3)

G210

FIG. 1403 POWER STEERING PUMP DRIVE MOTOR

1403

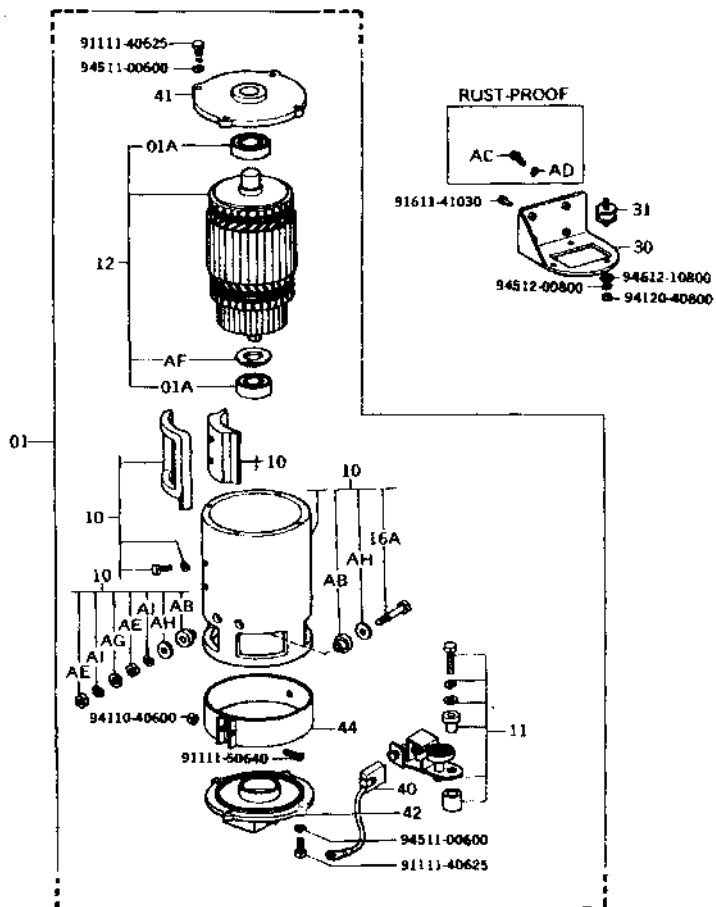

PART NAME CODE	PART NAME	QTY
1403-01	MOTOR ASSY, POWER STEERING -----	1
1403-01A	BEARING, POWER STEERING MOTOR -----	2
1403-10	YOKER ASSY, POWER STEERING MOTOR -----	1
1403-11	HOLDER ASSY, BRUSH -----	4
1403-12	ARMATURE ASSY, POWER STEERING -----	1
1403-16A	BOLT, STUD (TERMINAL) -----	1
1403-30	BRACKET SUB-ASSY, MOTOR MOUNTING -----	1
1403-31	INSULATOR SUB-ASSY, BODY MOUNTING -----	3
1403-40	BRUSH, POWER STEERING MOTOR -----	4
1403-41	BRACKET, NO.1 -----	1
1403-42	BRACKET, NO.2 -----	1
1403-44	COVER, BRUSH -----	1
1403-AB	INSULATOR -----	4
1403-AC	BOLT -----	4
1403-AD	WASHER, SPRING -----	4
1403-AE	NUT -----	4
1403-AF	FRINGER -----	1
1403-AG	WASHER, PLATE -----	4
1403-AH	WASHER, PLATE -----	4
1403-AI	WASHER, SPRING -----	4

1403-003

FIG. 2401 CONTROL PANEL

2401

(20D, 35D, 45D)

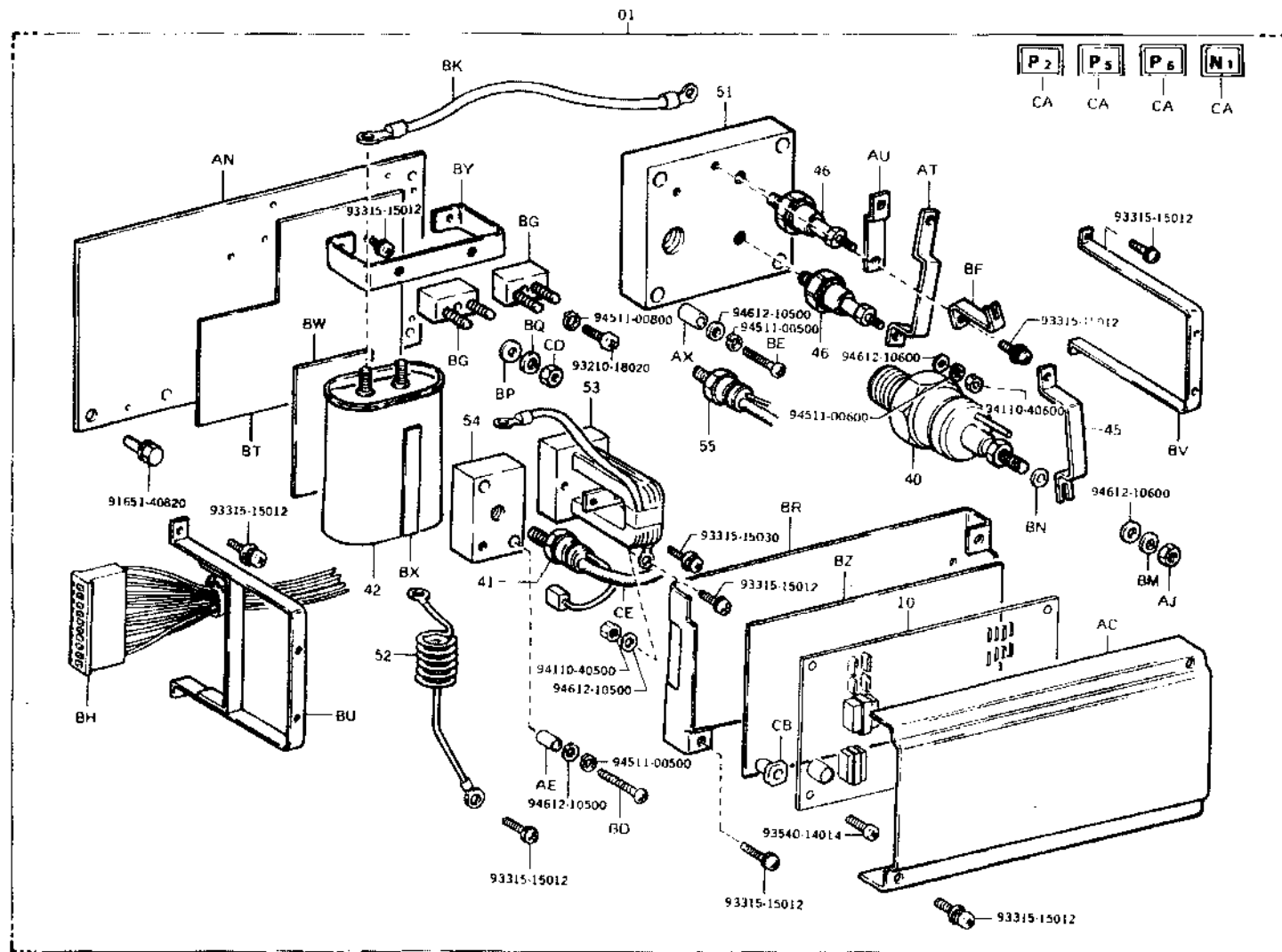

2401

PART NAME CODE	PART NAME	QTY
2401-01	PANEL ASSY, DRIVE CONTROL -----	1
2401-10	GENERATOR ASSY, SIGNAL -----	1
2401-40	THYRISTOR, MAIN -----	1
2401-41	THYRISTOR, SUB -----	1
2401-42	CONDENSER -----	1
2401-45	SENSOR, CURRENT -----	1
2401-46	DIPDIE -----	2
2401-51	HEATSINK, NO.1 -----	1
2401-52	REACTOR (L1) -----	1
2401-53	REACTOR (L2) -----	1
2401-54	HEATSINK, NO.2 -----	1
2401-55	THYRISTOR, SUB -----	1
2401-AC	COVER -----	1
2401-AE	INSULATOR -----	2
2401-AJ	NUT -----	1
2401-AN	BASE -----	1
2401-AT	BAR -----	1
2401-AU	BAR -----	1
2401-AX	INSULATOR -----	4
2401-BD	SCREW -----	2
2401-BE	SCREW -----	4
2401-BF	BAR -----	1
2401-BG	HOLDER, TERMINAL -----	2
2401-BH	HARNESS ASSY, WIRING -----	1
2401-BK	WIRING -----	1
2401-BM	WASHER, SPRING -----	1
2401-BN	WASHER, PLATE -----	1
2401-BP	WASHER, PLATE -----	4
2401-BQ	WASHER, SPRING -----	4
2401-BR	BASE -----	1
2401-BT	SHEET -----	1
2401-BU	BRACKET SUB-ASSY, CAPACITOR -----	1
2401-BV	BRACKET SUB-ASSY -----	1
2401-BW	MAT -----	1
2401-BX	MAT -----	1
2401-BY	BRACKET SUB-ASSY, TERMINAL -----	1
2401-BZ	SHEET -----	1
2401-CA	PLATE, NAME -----	1
2401-CB	GROMMET -----	4
2401-CC	PLATE -----	1
2401-CD	NUT -----	4
2401-CE	SLEEVE -----	1

FIG. 2402 CONTACTOR PANEL

2402

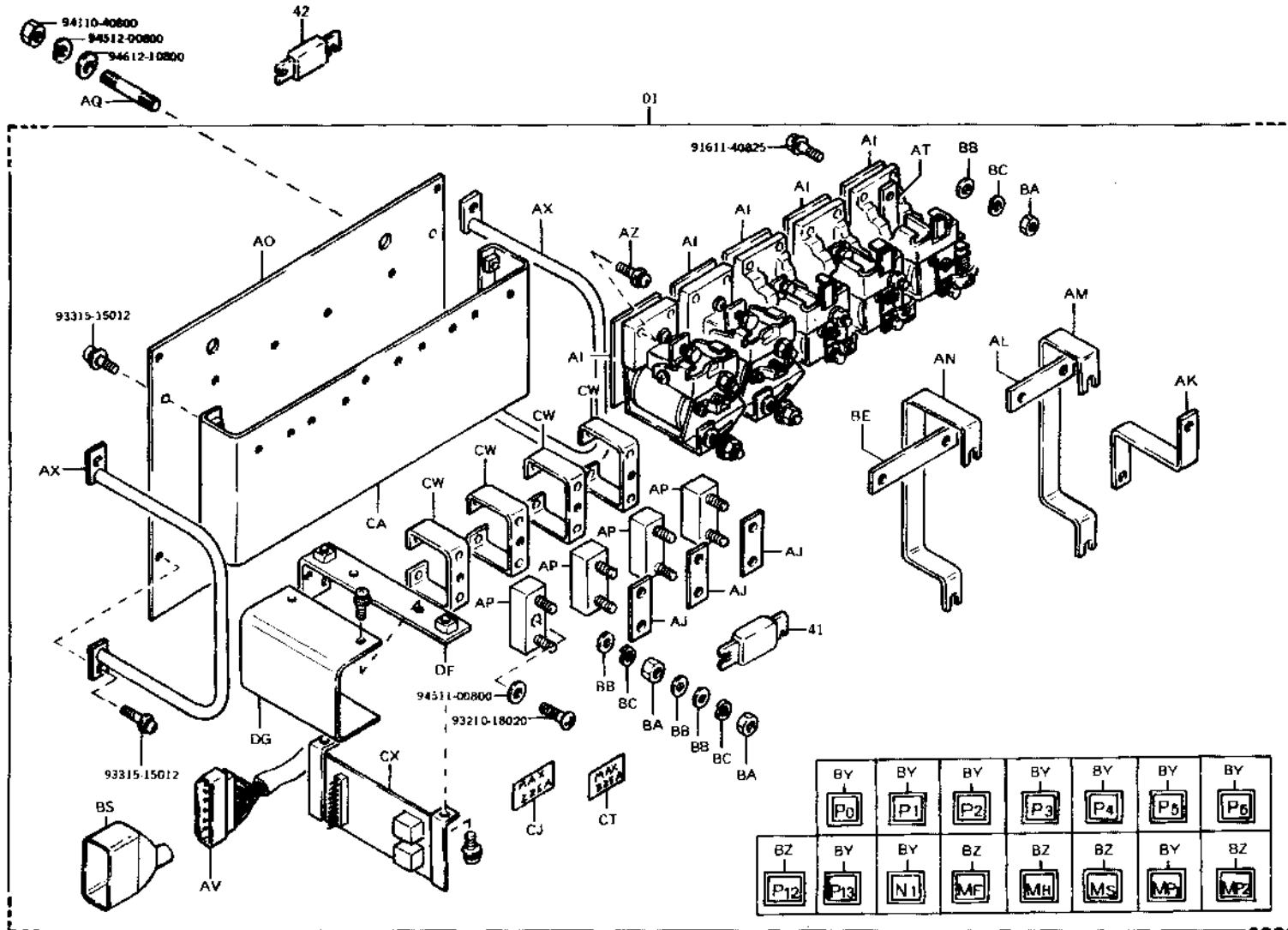

2402-031

FIG. 2402 CONTACTOR PANEL

2402

(UL-EE)

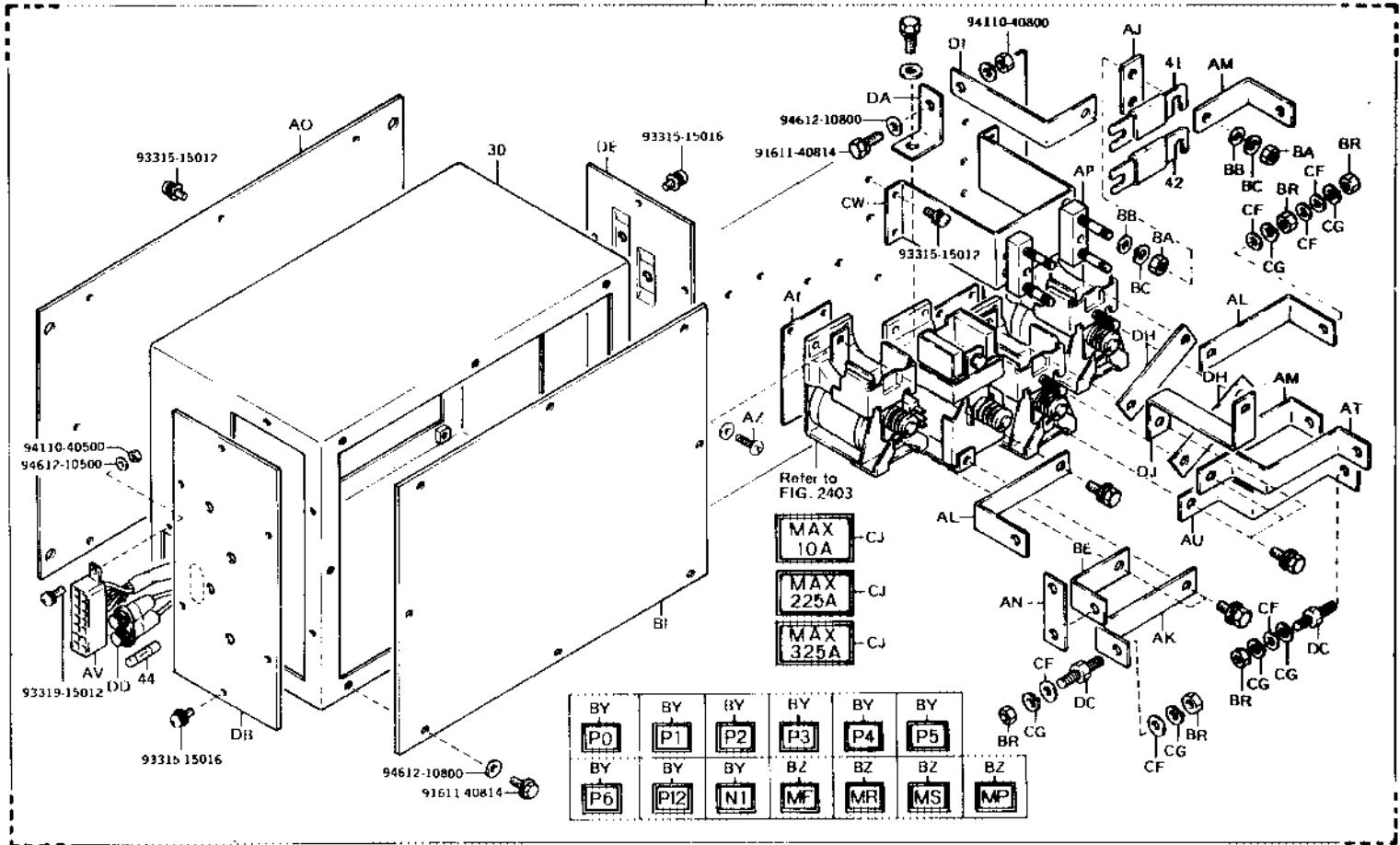
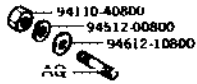

2402

PART NAME CODE	PART NAME	QTY
2402-01	PANEL ASSY, CONTACTOR -----	1
2402-30	COVER SUB-ASSY, CONTACTOR -----	1
2402-41	FUSE (F1) -----	1
2402-42	FUSE (F2) -----	1
2402-44	FUSE -----	2
2402-AI	INSULATOR -----	2
2402-AJ	BAR -----	1
2402-AK	BAR -----	1
2402-AL	BAR -----	2
2402-AM	BAR -----	1
2402-AN	BAR -----	1
2402-AO	BASE -----	1
2402-AP	HOLDER, TERMINAL -----	2
2402-AQ	STUD -----	4
2402-AT	BAR -----	1
2402-AU	BAR -----	1
2402-AV	HARNES ASSY, WIRING -----	1
2402-AX	HANDLE -----	2
2402-AZ	SCREW -----	2
2402-BA	NUT -----	8
2402-BB	WASHER -----	12
2402-BC	WASHER, SPRING -----	8
2402-BE	BAR -----	1
2402-BI	COVER -----	1
2402-BK	HOLDER, TERMINAL -----	1
2402-BR	NUT -----	15
2402-BS	BOOT -----	1
2402-BY	PLATE, TERMINAL NUMBER -----	1
2402-BZ	PLATE, NAME -----	1
2402-CA	PLATE SUB-ASSY, CONTACTOR -----	1
2402-CF	WASHER, PLATE -----	50
2402-CG	WASHER, SPRING -----	30
2402-CH	BAND -----	1
2402-CJ	PLATE, FUSE -----	1
2402-CW	BRACKET SUB-ASSY, TERMINAL -----	1
2402-CX	BOARD, PUMP CONTROL -----	1
2402-DB	PLATE, TERMINAL -----	1
2402-DC	BOLT, STUD -----	10
2402-DD	HOLDER SUB-ASSY, FUSE -----	1
2402-DE	PLATE, TERMINAL -----	1
2402-DF	STAND SUB-ASSY, PRINT BOARD -----	1
2402-OG	COVER, PRINT BOARD -----	1
2402-OH	BAR -----	2
2402-OI	BAR -----	1
2402-OJ	BAR -----	1

FIG. 2403 CONTACTOR ASSY

2403

(UL-EE)

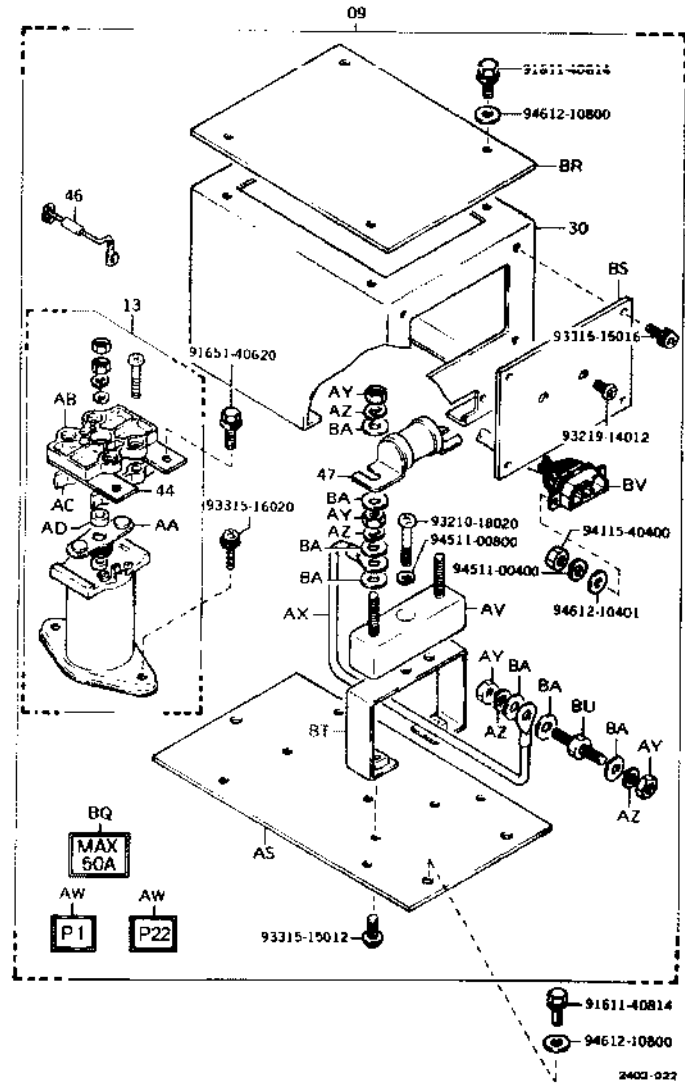
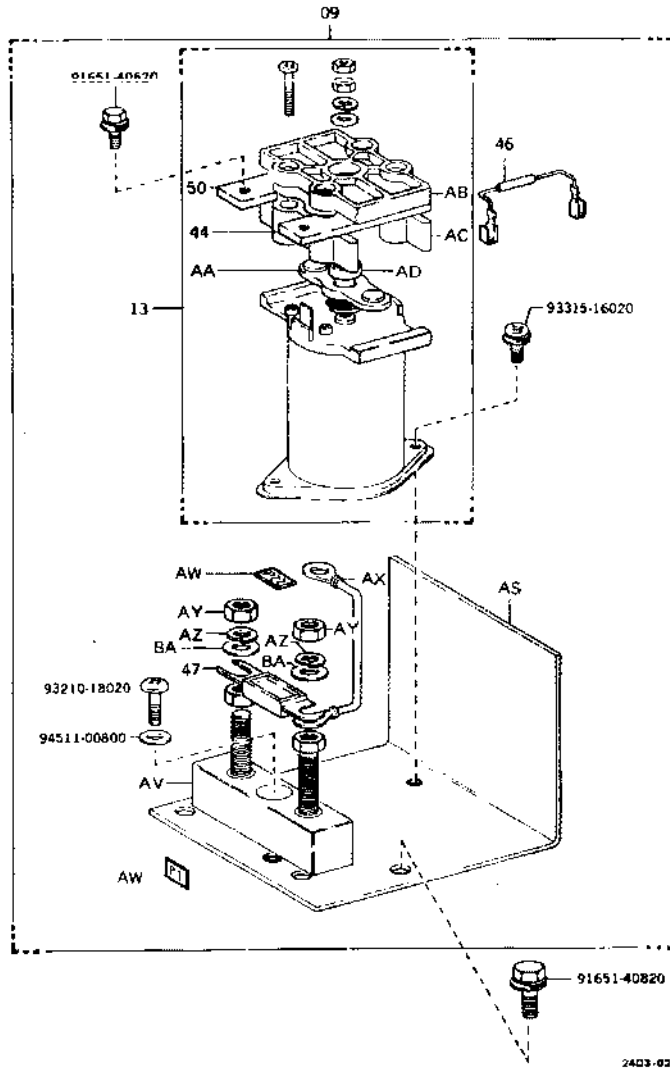
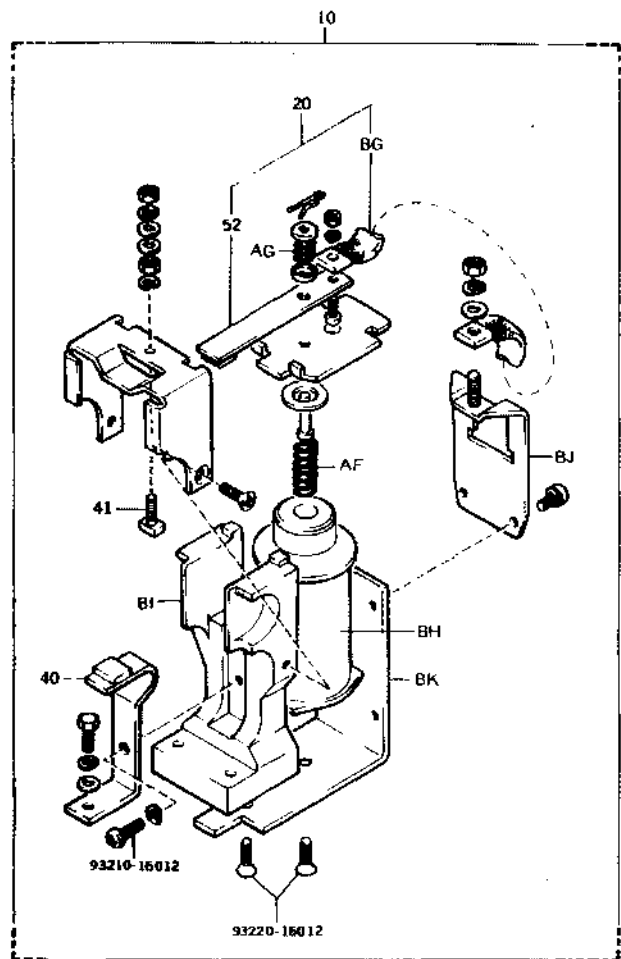

FIG. 2403 CONTACTOR ASSY

2403

[DRIVE]

[SHORT]



2403-019

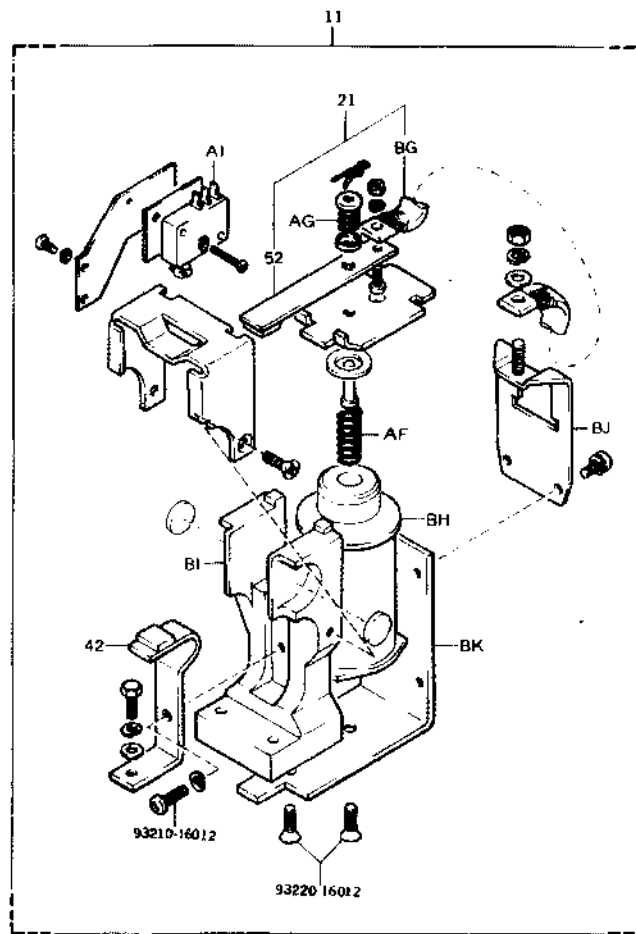

2403-020

FIG. 2403 CONTACTOR ASSY

2403

[PUMP]

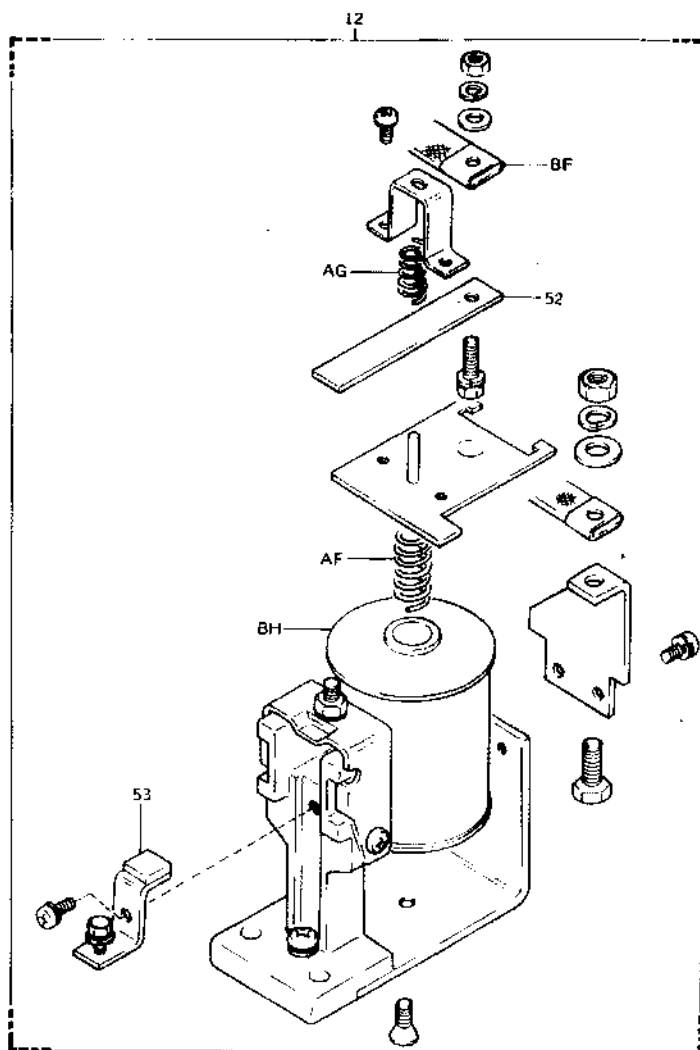

2403-018

PART NAME CODE	PART NAME	QTY
2403-09	CONTACTOR ASSY, POWER STEERING, LARGE	1
2403-10	CONTACTOR ASSY, DRIVE	2
2403-11	CONTACTOR ASSY, SHORT	1
2403-12	CONTACTOR ASSY, PUMP	2
2403-13	CONTACTOR ASSY, POWER STEERING	1
2403-20	CONTACT SUB-ASSY, DRIVE MOVING	2
2403-21	CONTACT SUB-ASSY, SHORT MOVING	1
2403-30	COVER SUB-ASSY, CONTACTOR	1
2403-40	CONTACT, DRIVE FIXED, NO.1	2
2403-41	CONTACT, DRIVE FIXED, NO.2	2
2403-42	CONTACT, SHORT FIXED	1
2403-44	CONTACT, POWER STEERING FIXED	1
2403-46	DIODE	1
2403-47	FUSE (F3)	1
2403-50	CONTACT, POWER STEERING	1
2403-52	CONTACT, MOVING	1
2403-53	CONTACT, STATIONARY	2
2403-AA	MOVING, CONTACT	1
2403-AB	COVER	1
2403-AC	POLE	2
2403-AD	BUSHING, STEPPED, NO.1	2
2403-AF	SPRING, NO.1	2
2403-AG	SPRING, NO.2	2
2403-AI	SWITCH, MICRO	1
2403-AS	BASE	1
2403-AV	HOLDER, TERMINAL	1
2403-AW	PLATE, TERMINAL NUMBER	1
2403-AX	WIRING SUB-ASSY	1
2403-AY	NUT	4
2403-AZ	WASHER, SPRING	4
2403-BA	WASHER, PLATE	6
2403-BF	WIRING	2
2403-BG	WIRE, LEAD	3
2403-BH	COIL	2
2403-BI	INSULATOR	3
2403-BJ	SUPPORT	3
2403-BK	FRAME	3
2403-BQ	PLATE, FUSE	1
2403-BR	COVER	1
2403-BS	PLATE, TERMINAL	1
2403-BT	BRACKET SUB-ASSY, TERMINAL	1
2403-BU	BOLT, STUO	2
2403-BV	WIRING SUB-ASSY	1

(MAIN) (7)

G210

FIG. 2413 CIRCUIT BREAKER

2413

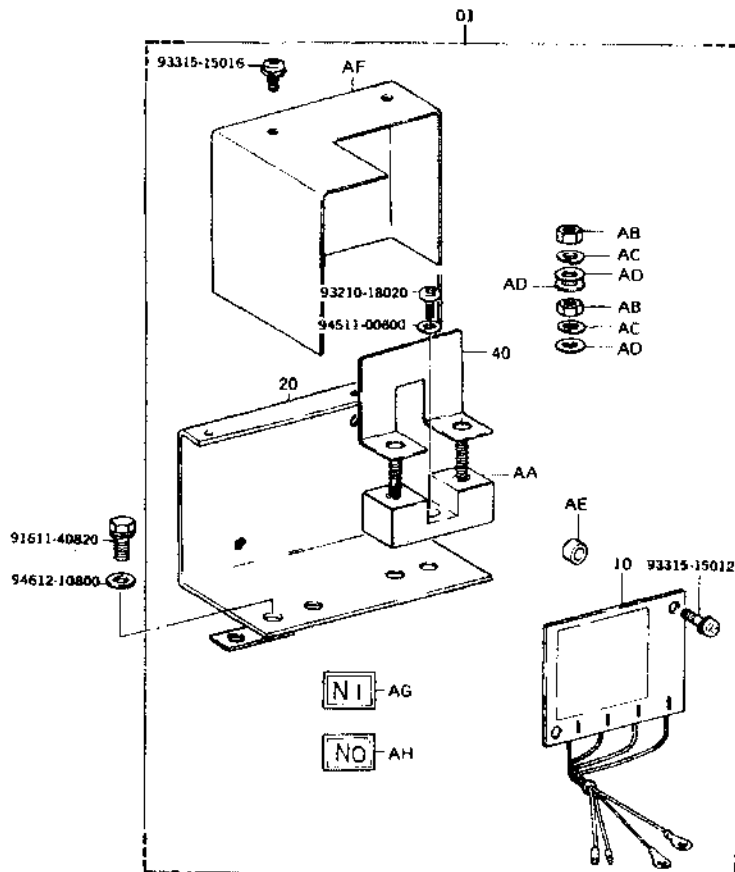

PART NAME CODE	PART NAME	QTY
2413-01	BREAKER ASSY, CIRCUIT -----	1
2413-10	BOARD ASSY, CIRCUIT -----	1
2413-20	BASE SUB-ASSY, BREAKER -----	1
2413-40	RESISTER -----	1
2413-AA	TERMINAL BLOCK, FUSE -----	1
2413-AB	NUT -----	4
2413-AC	WASHER, SPRING -----	4
2413-AD	WASHER, PLATE -----	8
2413-AE	SPACER -----	2
2413-AF	COVER -----	1
2413-AG	PLATE, TERMINAL NUMBER (N1) -----	1
2413-AH	PLATE, TERMINAL NUMBER (NO) -----	1

FIG. 2501 BATTERY

2501

(G.S)

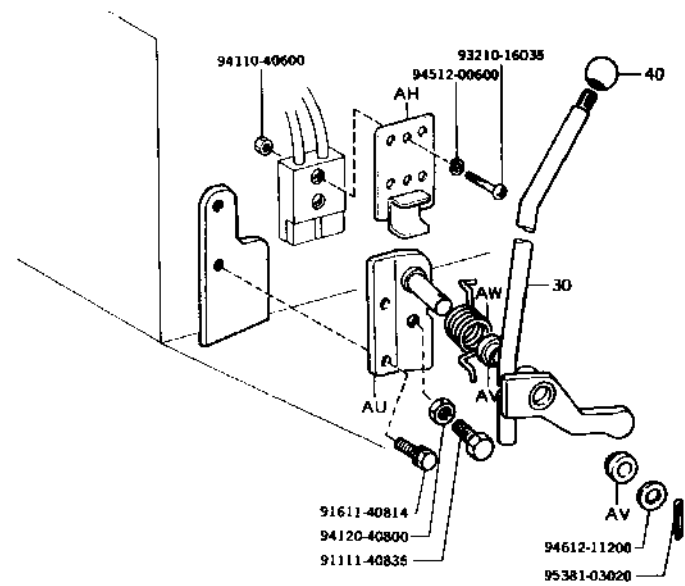
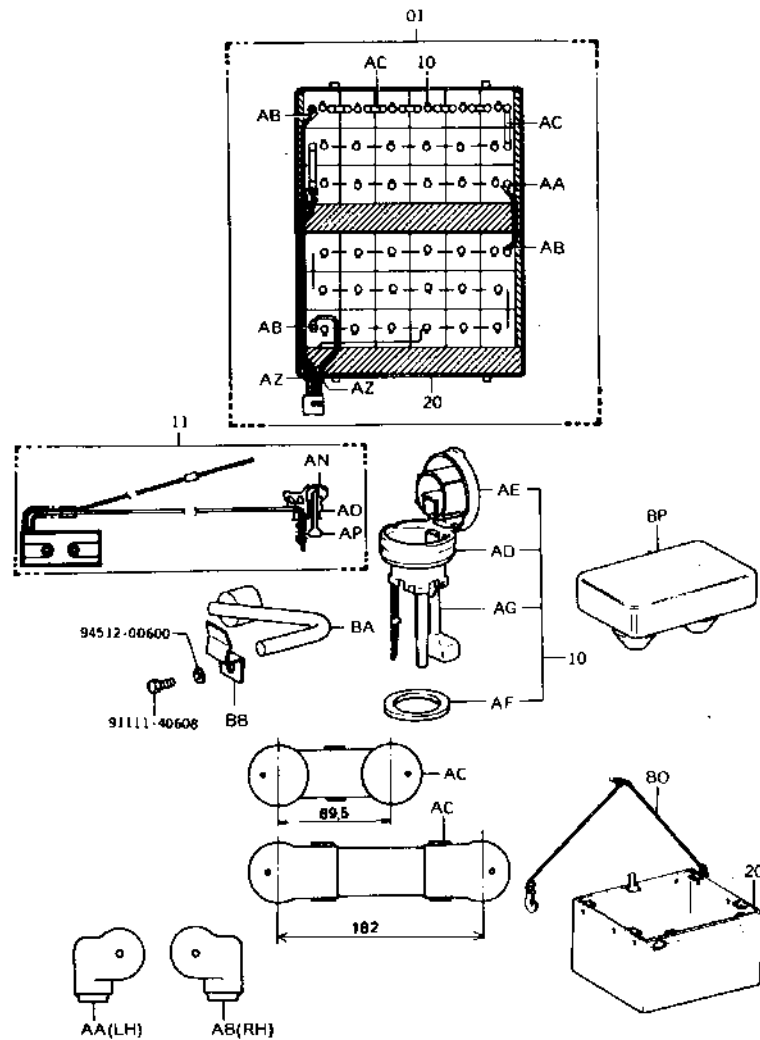

2501-005

2501-083

2501

PART NAME CODE	PART NAME	QTY
2501-01	BATTERY ASSY, W/CASE -----	1
2501-10	PLUG ASSY, VENT -----	36
2501-11	SENSOR ASSY, LEVEL -----	1
2501-20	CASE SUB-ASSY, BATTERY -----	1
2501-30	LEVER SUB-ASSY, EMERGENCY -----	1
2501-40	KNOB, EMERGENCY LEVER -----	1
2501-41	PLUG, BATTERY -----	1
2501-AA	COVER, TERMINAL, LH -----	1
2501-AB	COVER, TERMINAL, RH -----	3
2501-AC	COVER, TERMINAL -----	1
2501-AD	PLUG, VENT -----	36
2501-AE	CAP -----	36
2501-AF	PACKING -----	36
2501-AG	FLOAT -----	36
2501-AH	BRACKET -----	1
2501-AN	CAP -----	1
2501-AD	PACKING -----	1
2501-AP	FLOAT -----	1
2501-AU	BRACKET SUB-ASSY, EMERGENCY LEVER -----	1
2501-AV	BUSHING -----	2
2501-AW	SPRING, TORSION -----	1
2501-AZ	BUSHING -----	1
2501-BA	STOPPER SUB-ASSY, BATTERY CASE -----	1
2501-BB	SPRING, BATTERY STOPPER -----	1
2501-BD	HANGER -----	2
2501-BP	RUBBER, CUSHION -----	7

FIG. 2512 BATTERY SEPARATE CHARGER

2512

(G.S)

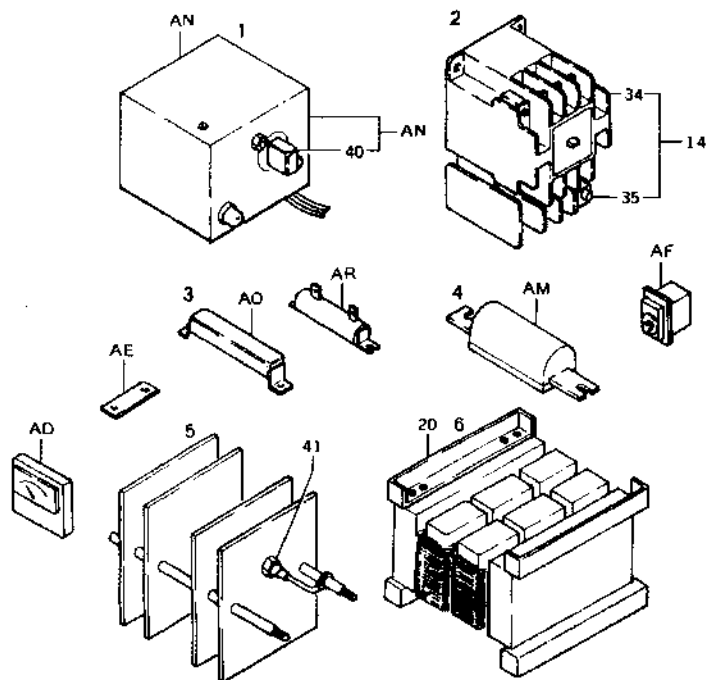
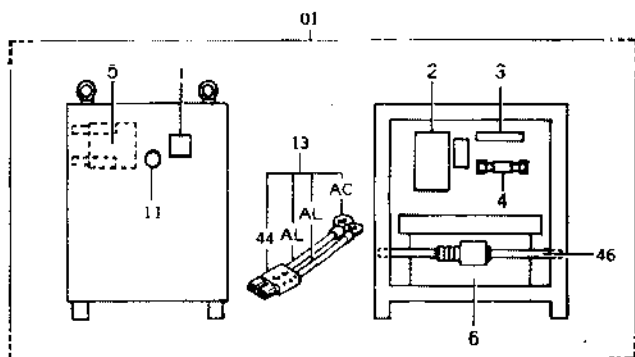

2512-018

PART NAME CODE	PART NAME	QTY
2512-01	CHARGER ASSY, BATTERY SEPARATE	1
2512-11	LAMP ASSY, CHARGING	1
2512-13	CABLE ASSY, CHARGER (DC)	1
2512-14	SWITCH ASSY, MAGNET	1
2512-20	TRANSFORMER SUB-ASSY	1
2512-34	SWITCH SUB-ASSY, MAGNET	1
2512-35	RELAY SUB-ASSY, THERMAL	1
2512-40	HANDLE	1
2512-41	ELEMENT, SILICON, FORWARD	6
2512-44	PLUG	1
2512-46	CABLE (AC)	1
2512-AC	TERMINAL	2
2512-AD	METER ASSY, AMPERE	1
2512-AE	SHUNT	1
2512-AF	TIMER ASSY, TOTAL	1
2512-AL	CABLE	2
2512-AM	FUSE ASSY	1
2512-AN	AVT ASSY	1
2512-AO	RESISTOR	1
2512-AR	RESISTOR	1

(MAIN) (10)

G210

FIG. 2611 ACCELERATOR

2611

(ACCELERATOR BOX)

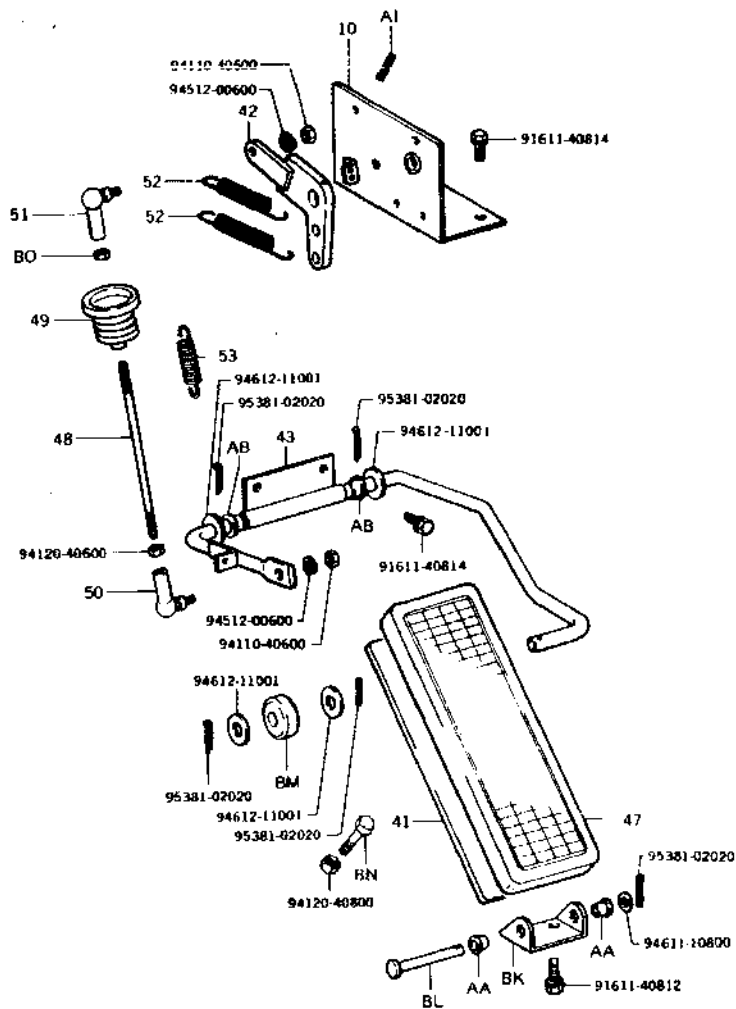

2611 012

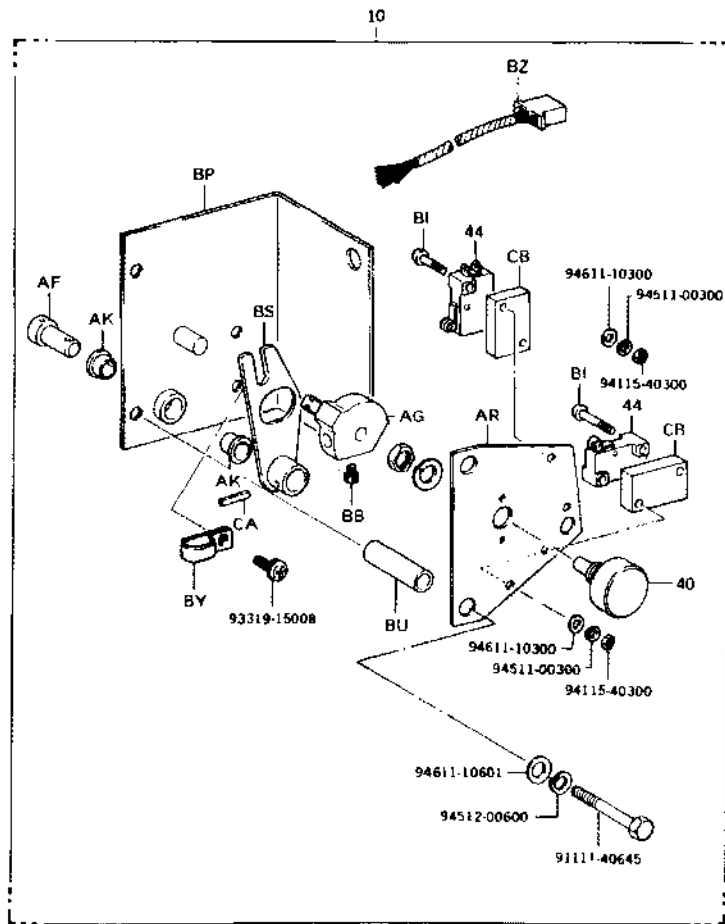

2611 011

2611

PART NAME CODE	PART NAME	QTY
2611-10	SWITCH ASSY, ACCELERATOR (PEDAL TYPE) -----	1
2611-40	VARI-OHM -----	1
2611-41	PEDAL, ACCELERATOR -----	1
2611-42	ARM, ACCELERATOR LINK -----	1
2611-43	ROD, ACCELERATOR PEDAL -----	1
2611-44	SWITCH, MICRO -----	2
2611-47	PAD, PEDAL -----	1
2611-48	ROD, ACCELERATOR LINK -----	1
2611-49	BOOT -----	1
2611-50	END, CONNECTING ROD, NO.1 -----	1
2611-51	END, CONNECTING ROD, NO.2 -----	1
2611-52	SPRING, TENSION, NO.1 -----	2
2611-53	SPRING, TENSION, NO.2 -----	1
2611-AA	BUSHING -----	2
2611-AB	BUSHING -----	2
2611-AF	SHAFT -----	1
2611-AG	CAM -----	1
2611-AI	PIN, SPRING -----	1
2611-AK	BUSHING -----	2
2611-AR	SUPPORT -----	1
2611-BB	SCREW -----	4
2611-BI	SCREW -----	4
2611-BK	BRACKET, PEDAL -----	1
2611-BL	PIN, W/WASHER -----	1
2611-BM	ROD, ACCELERATOR LINK -----	1
2611-BN	BDLT -----	1
2611-BO	NUT -----	1
2611-BP	HOLDER -----	1
2611-BS	LEVER, SWITCH -----	1
2611-BU	SPACER -----	3
2611-BY	CLAMP -----	1
2611-BZ	HARNESS SUB-ASSY -----	1
2611-CA	PIN, SPRING -----	1
2611-CB	PLATE -----	2

FIG. 3305 GEAR CASE & GEAR

3305

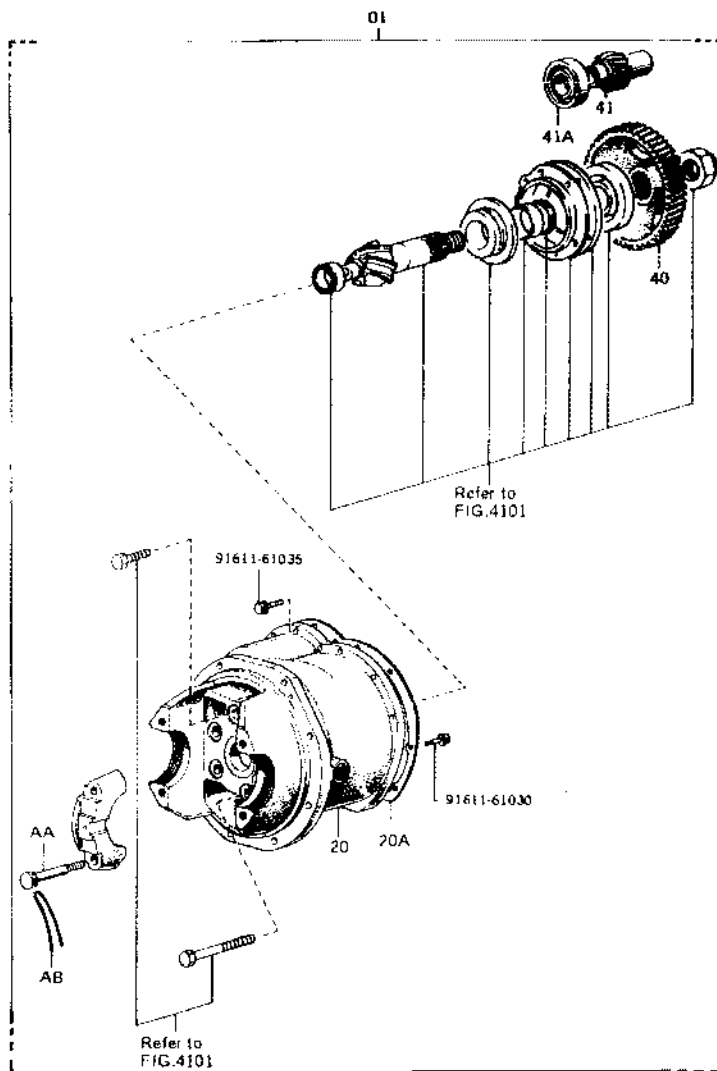

3305-001

PART NAME CODE	PART NAME	QTY
3305-01	CASE ASSY, GEAR -----	1
3305-20	CASE SUB ASSY, GEAR -----	1
3305-20A	GASKET, GEAR CASE -----	1
3305-40	GEAR, OUTPUT -----	1
3305-41	GEAR, DRIVE -----	1
3305-41A	BEARING (FOR DRIVE GEAR) -----	1
3305-AA	BOLT -----	4
3305-AB	WIRE -----	2

(MAIN) (12)

G210

FIG. 3310 CHANGE LEVER

3310

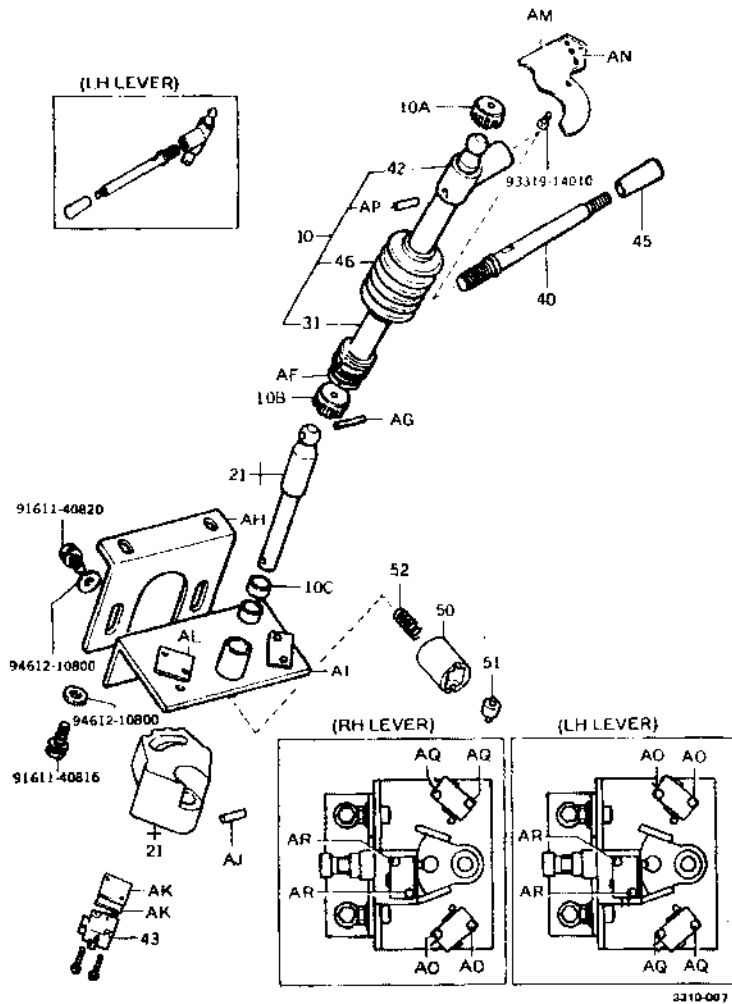

PART NAME CODE	PART NAME	QTY
3310-10	SHAFT ASSY, DIRECTION SWITCH	1
3310-10A	BUSH, NO.1 (FOR DIRECTION SWITCH SHAFT)	1
3310-10B	BUSH, NO.2 (FOR DIRECTION SWITCH SHAFT)	1
3310-10C	BUSH, NO.3 (FOR DIRECTION SWITCH SHAFT)	2
3310-21	CAM SUB-ASSY, DIRECTION SWITCH	1
3310-31	SHAFT SUB-ASSY, DIRECTION SWITCH	1
3310-40	LEVER	1
3310-42	HOUSING, CHANGE LEVER	1
3310-43	SWITCH, MICRO, NO.1	1
3310-45	KNOB	1
3310-46	BOOT (FOR CONTROL SHAFT)	1
3310-50	HOUSING, ROLLER	1
3310-51	ROLLER	1
3310-52	SPRING, COMPRESSION	1
3310-AF	SPRING, PIN STOPPER	1
3310-AG	ROLLER, NEEDLE	1
3310-AH	STAY, DIRECTION SWITCH BRACKET	1
3310-AI	BRACKET SUB-ASSY, DIRECTION SWITCH	1
3310-AJ	PIN, SPRING	1
3310-AK	PLATE	3
3310-AL	NUT, PLATE	1
3310-AM	PLATE, CHANGE LEVER	1
3310-AN	PLATE, INDICATOR	1
3310-AO	SCREW	2
3310-AP	PIN, SPRING	1
3310-AQ	SCREW	4
3310-AR	SCREW	2

FIG. 4101 DIFFERENTIAL

4101

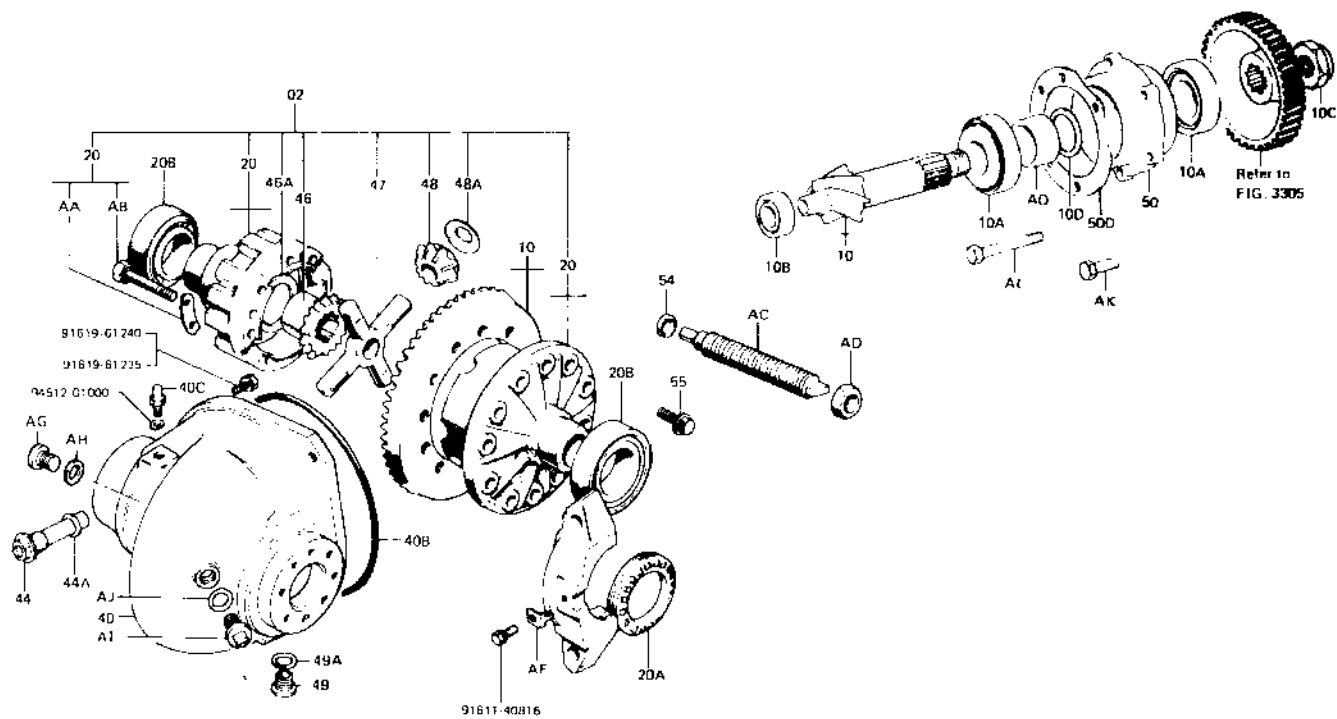

4101

PART NAME CODE	PART NAME	QTY
4101-02	CASE ASSY, DIFFERENTIAL -----	1
4101-10	RING GEAR & PINION SET, DIFFERENTIAL -----	1
4101-10A	BEARING, DRIVE PINION -----	2
4101-10B	BEARING, DRIVE PINION PILOT -----	1
4101-10C	NUT, LOCK -----	1
4101-10D	SHIM, BEARING PRELOAD ADJUST -----	99
4101-20	CASE SUB-ASSY, DIFFERENTIAL -----	1
4101-20A	NUT, ADJUSTING -----	2
4101-20B	BEARING, DIFFERENTIAL CASE -----	2
4101-40	HOUSING, DIFFERENTIAL -----	1
4101-40B	RING, O (FOR DIFFERENTIAL HOUSING) -----	1
4101-40C	PLUG, BREATHER (FOR DIFFERENTIAL HOUSING) --	1
4101-44	PLUG (FOR INPUT SHAFT) -----	1
4101-44A	PACKING (FOR INPUT SHAFT PLUG) -----	1
4101-46	GEAR, SIDE -----	2
4101-46A	WASHER, SIDE GEAR THRUST -----	2
4101-47	SPIDER -----	1
4101-48	PINION -----	4
4101-48A	WASHER, PINION THRUST -----	4
4101-49	PLUG, DRAIN -----	1
4101-49A	GASKET, DRAIN -----	1
4101-50	RETAINER, DRIVE PINION BEARING -----	1
4101-500	SHIM, DIFFERENTIAL DRIVE PINION BEARING ----	99
4101-54	CAP, RING GEAR THRUST SCREW -----	1
4101-55	BOLT, RING GEAR SET -----	12
4101-AB	BOLT -----	16
4101-AC	SCREW, RING GEAR THRUST -----	1
4101-AD	NUT -----	1
4101-AF	LOCK, ADJUSTING -----	2
4101-AG	PLUG, W/HEAD STRAIGHT SCREW -----	1
4101-AH	GASKET -----	1
4101-AI	PLUG -----	1
4101-AJ	GASKET -----	1
4101-AK	BOLT -----	2
4101-AL	BOLT -----	4
4101-AO	SPACER, BEARING -----	1

FIG. 4201 FRONT AXLE SHAFT

4201

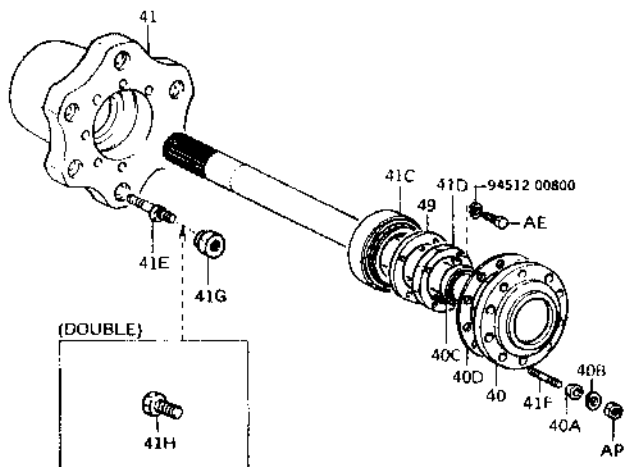
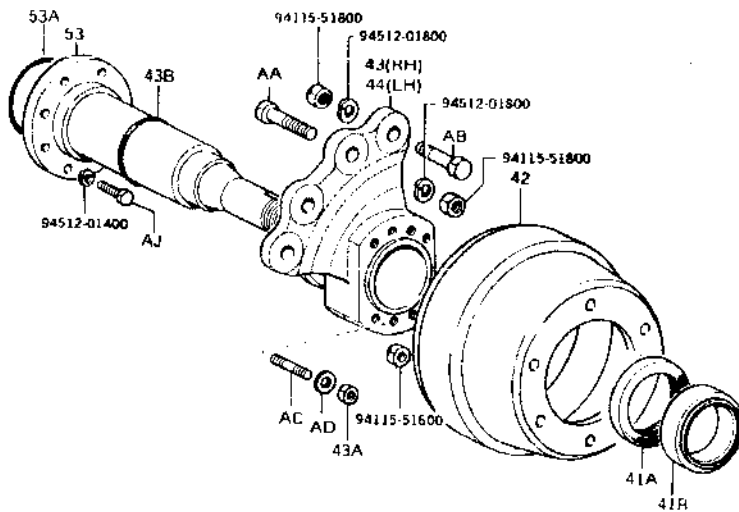

4201-013

PART NAME CODE	PART NAME	QTY
4201-40	SHAFT, FRONT AXLE -----	2
4201-40A	WASHER, CORN -----	16
4201-40B	WASHER, SPRING (FOR FRONT AXLE SHAFT) -----	16
4201-40C	SEAL, OIL (FOR FRONT AXLE SHAFT) -----	2
4201-40D	GASKET, FRONT AXLE SHAFT -----	2
4201-41	HUB, FRONT AXLE -----	2
4201-41A	SEAL, OIL (FOR FRONT AXLE HUB) -----	2
4201-41B	BEARING, NO.1 (FOR FRONT AXLE HUB) -----	2
4201-41C	BEARING, NO.2 (FOR FRONT AXLE HUB) -----	2
4201-41D	NUT, BEARING LOCK -----	2
4201-41E	BOLT, HUB -----	12
4201-41F	BOLT, STUD (FOR FRONT AXLE SHAFT) -----	16
4201-41G	NUT, HUB -----	12
4201-41H	BOLT, DOUBLE WHEEL STOP -----	12
4201-42	DRUM, BRAKE -----	2
4201-43	BRACKET, FRONT AXLE, RH -----	1
4201-43A	NUT, BRAKE SET SELF -----	8
4201-43B	RING, O (FOR FRONT AXLE BRACKET) -----	2
4201-44	BRACKET, FRONT AXLE, LH -----	1
4201-49	PLATE, LOCK NUT -----	2
4201-53	HOUSING, FRONT AXLE -----	2
4201-53A	RING, O (FOR FRONT AXLE HOUSING) -----	2
4201-AA	BOLT -----	4
4201-AB	BOLT, BRACKET SET -----	4
4201-AC	BOLT, STUD BRAKE SET -----	16
4201-AD	WASHER, CD SPRING -----	16
4201-AE	BOLT -----	2
4201-AJ	BOLT -----	16
4201-AP	NUT -----	16

FIG 4301 REAR AXLE & TIE-ROD

4301

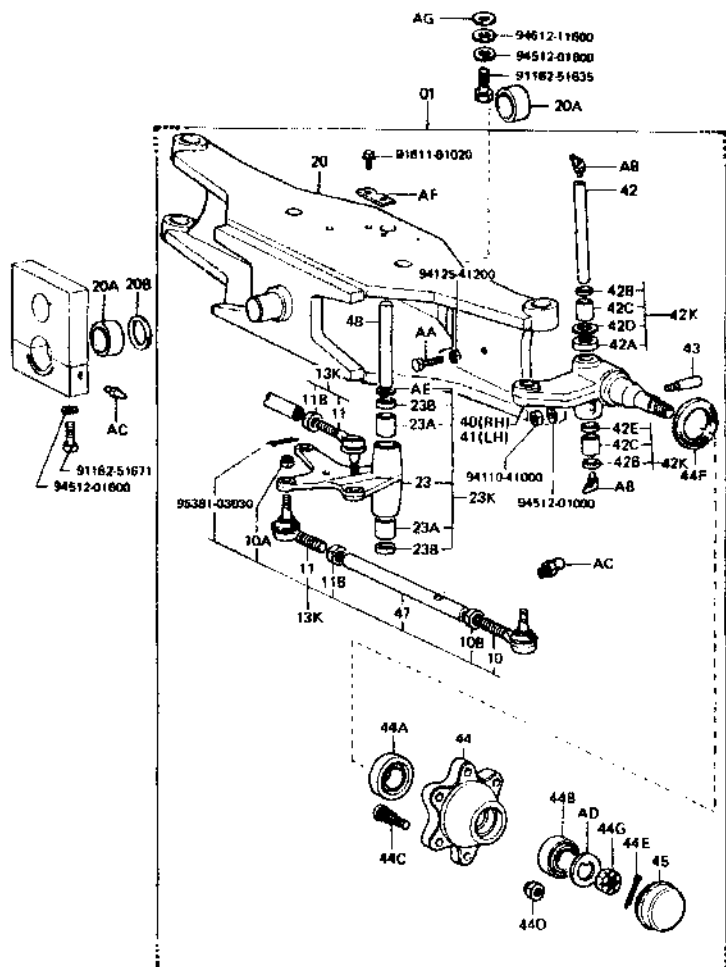

4301-007

PART NAME CODE	PART NAME	QTY
4301-01	AXLE ASSY, RR	1
4301-10	END ASSY, TIE-ROD, NO.1	2
4301-10A	NUT, CASTLE (FOR TIE-ROD END)	4
4301-10B	NUT (RH THREADS)	2
4301-11	END ASSY, TIE-ROD, NO.2	2
4301-11B	NUT (LH THREADS)	2
4301-13K	TIE-ROD KIT	1
4301-20	BEAM SUB-ASSY, REAR AXLE	1
4301-20A	BUSH, REAR AXLE BEAM	2
4301-20B	SHIM, REAR AXLE BEAM	1
4301-23	BELLCRANK SUB-ASSY, STEERING	1
4301-23A	BEARING (FOR STEERING BELLCRANK)	2
4301-23B	SEAL, OIL (FOR STEERING BELLCRANK)	2
4301-23K	SEAL KIT, BELLCRANK PIN	1
4301-40	KNUCKLE, STEERING, RH	1
4301-41	KNUCKLE, STEERING, LH	1
4301-42	PIN, STEERING KNUCKLE KING	2
4301-42A	BEARING, STEERING KNUCKLE THRUST	2
4301-42B	SEAL, OIL, NO.1	4
4301-42C	BEARING, NEEDLE	4
4301-42D	SHIM, STEERING KNUCKLE	99
4301-42E	SEAL, OIL, NO.2	2
4301-42K	SEAL KIT, KING PIN	2
4301-43	PIN, KING PIN LOCK	2
4301-44	HUB, REAR AXLE	2
4301-44A	BEARING, INNER	2
4301-44B	BEARING, OUTER	2
4301-44C	BOLT, HUB	12
4301-44D	NUT, HUB	12
4301-44E	PIN, REAR AXLE COTTER	2
4301-44F	SEAL, OIL (FOR REAR AXLE HUB)	2
4301-44G	NUT, CASTLE (FOR REAR AXLE HUB)	2
4301-45	CAP, REAR AXLE HUB	2
4301-47	TIE-ROD	2
4301-48	PIN, BELLCRANK	1
4301-AA	BOLT	2
4301-AB	FITTING, GREASE	4
4301-AC	FITTING, GREASE	1
4301-AD	WASHER, CRAW	2
4301-AE	SHIM	99
4301-AF	PLATE, STOPPER	1
4301-AG	WASHER	2

FIG. 4401 FRONT WHEEL & TIRE (SINGLE)

4401

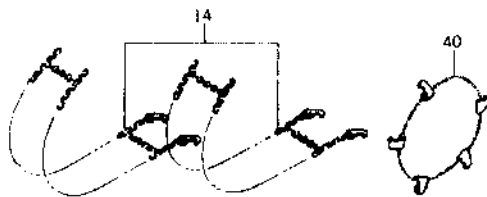
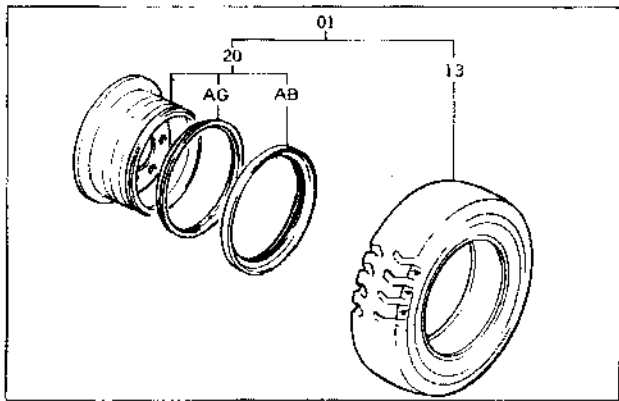
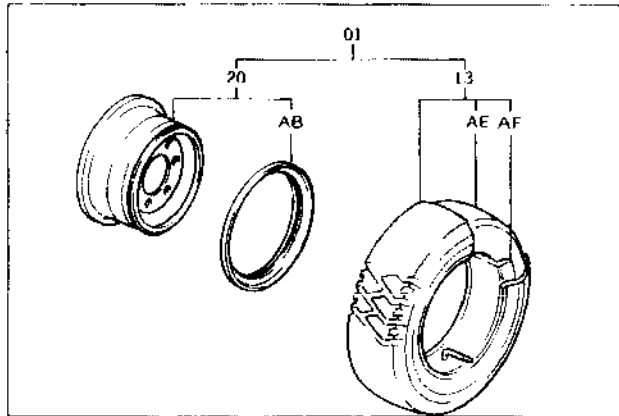

4401 004

PART NAME	PART NAME	QTY
4401-01	WHEEL ASSY -----	2
4401-13	TIRE ASSY -----	2
4401-14	CHAIN ASSY, TIRE -----	1
4401-20	WHEEL SUB-ASSY, DISC -----	2
4401-40	BAND, CHAIN -----	2
4401-AB	RING, LOCK -----	2
4401-AE	TUBE SUB-ASSY -----	2
4401-AF	FLAP -----	2
4401-AG	RING, SIDE -----	2

(MAIN) (17)

G210

FIG. 4402 FRONT WHEEL & TIRE (DOUBLE)

4402

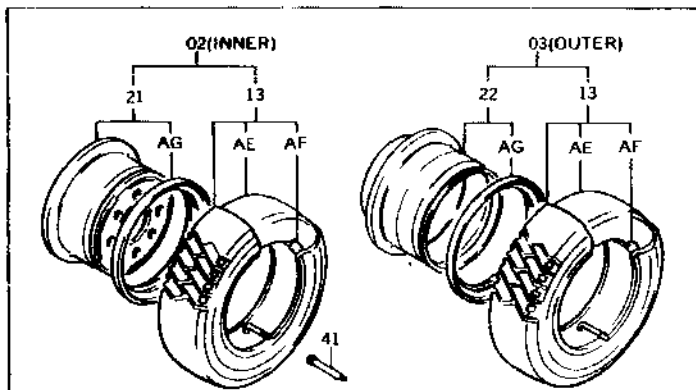

(2-PIECE RING)

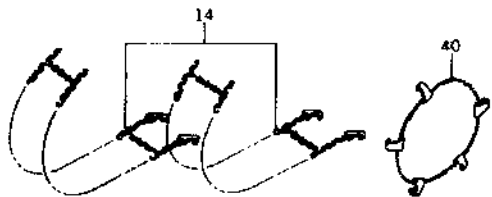
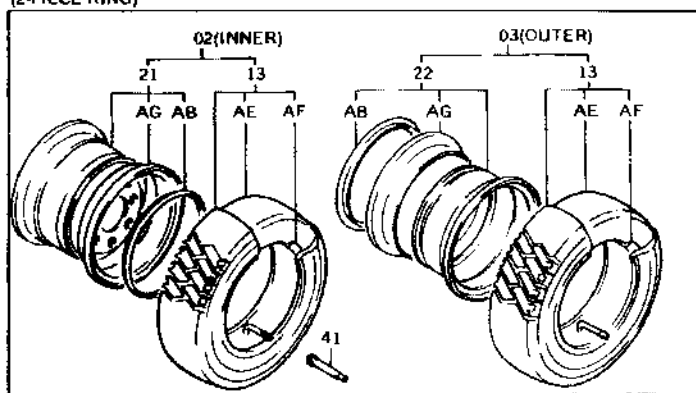

4402-004

PART NAME CODE	PART NAME	QTY
4402-02	WHEEL ASSY, INNER -----	2
4402-03	WHEEL ASSY, OUTER -----	2
4402-13	TIRE ASSY -----	4
4402-14	CHAIN ASSY, TIRE -----	1
4402-21	WHEEL SUB-ASSY, DISC, INNER -----	2
4402-22	WHEEL SUB-ASSY, DISC, OUTER -----	2
4402-40	BAND, CHAIN -----	2
4402-41	EXTENSION, WHEEL TUBE VALVE -----	2
4402-AB	RING, LOCK -----	4
4402-AE	TUBE SUB-ASSY -----	4
4402-AF	FLAP -----	4
4402-AG	RING, SIDE -----	4

FIG. 4403 REAR WHEEL & TIRE

4403

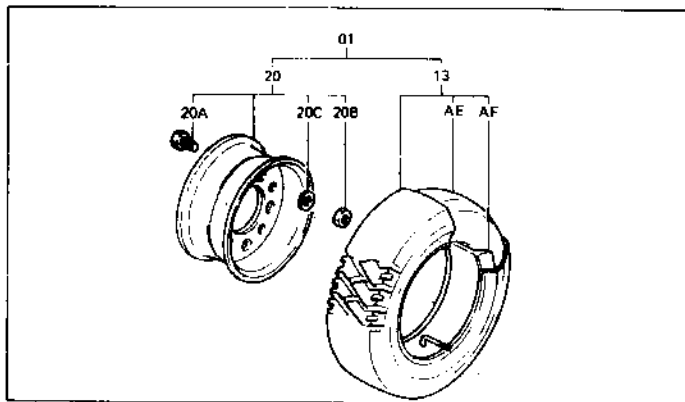

(UNIQUE TRUKUSH)

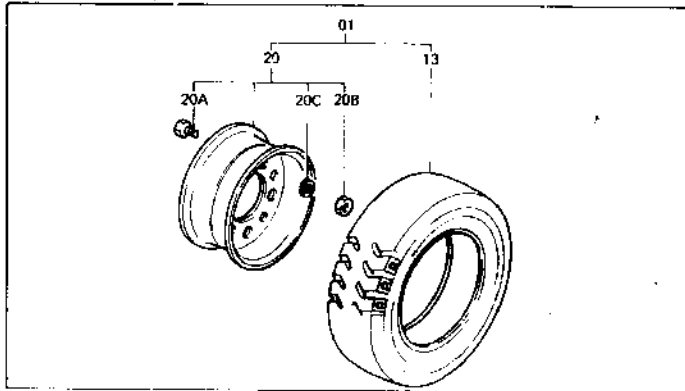

PART NAME CODE	PART NAME	QTY
4403-01	WHEEL ASSY -----	2
4403-13	TIRE ASSY -----	2
4403-20	WHEEL SUB-ASSY, DISC -----	2
4403-20A	BOLT, DISC WHEEL SET -----	12
4403-20B	NUT, WHEEL SET -----	12
4403-20C	WASHER, WHEEL SET -----	12
4403-AE	TUBE SUB-ASSY -----	2
4403-AF	FLAP -----	2

4403-003

FIG. 4501 STEERING WHEEL

4501

(UL-EE)

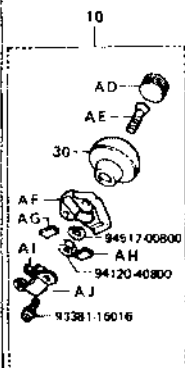
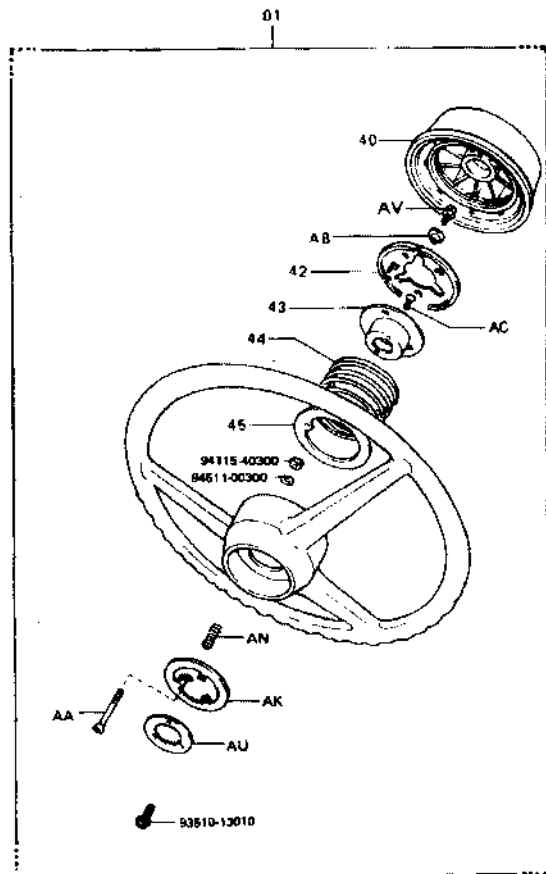

4501 004

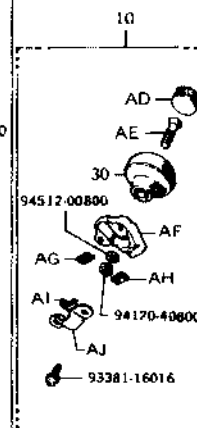
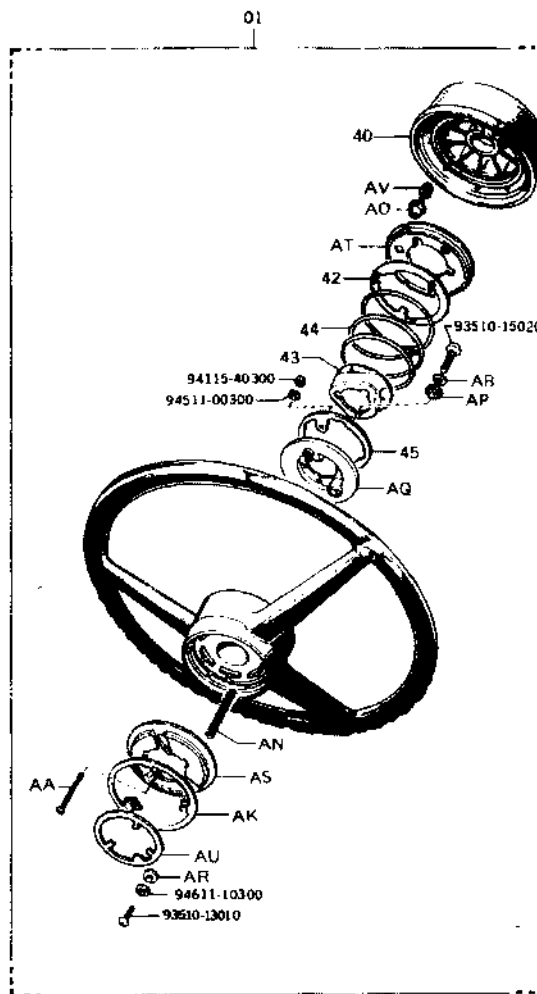

4501 006 A

4501

PART NAME CODE	PART NAME	QTY
4501-01	WHEEL ASSY, STEERING -----	1
4501-10	KNOB ASSY, STEERING WHEEL -----	1
4501-30	KNOB SUB-ASSY, STEERING WHEEL -----	1
4501-40	BUTTON, HORN -----	1
4501-42	PLATE, HORN CONTACT -----	1
4501-43	SEAT, HORN CONTACT -----	1
4501-44	SPRING, HORN -----	1
4501-45	PLATE, LEAD -----	1
4501-AA	SCREW -----	1
4501-AB	WASHER -----	3
4501-AC	SCREW -----	3
4501-AD	CAP, STEERING WHEEL -----	1
4501-AE	BOLT, STEERING WHEEL KNOB SET -----	1
4501-AF	BRACKET, STEERING WHEEL KNOB -----	1
4501-AG	SEAT, STEERING WHEEL KNOB BRACKET -----	1
4501-AH	SEAT, STEERING WHEEL KNOB BRACKET -----	1
4501-AI	SEAT, WHEEL KNOB SET PLATE -----	1
4501-AJ	PLATE, STEERING WHEEL KNOB SET -----	1
4501-AK	RING, HORN CONTACT NO.1 -----	1
4501-AN	SPRING, LEAD -----	1
4501-AD	SPACER, NO.3 -----	3
4501-AP	SPACER, NO.5 -----	3
4501-AQ	SPACER, NO.5 -----	1
4501-AR	SPACER, NO.4 -----	2
4501-AS	SPACER, NO.1 -----	1
4501-AT	PLATE, HORN BUTTON SET -----	1
4501-AU	RING, HORN CONTACT NO.2 -----	1
4501-AV	SCREW -----	3

FIG. 4502 STEERING POST

4502

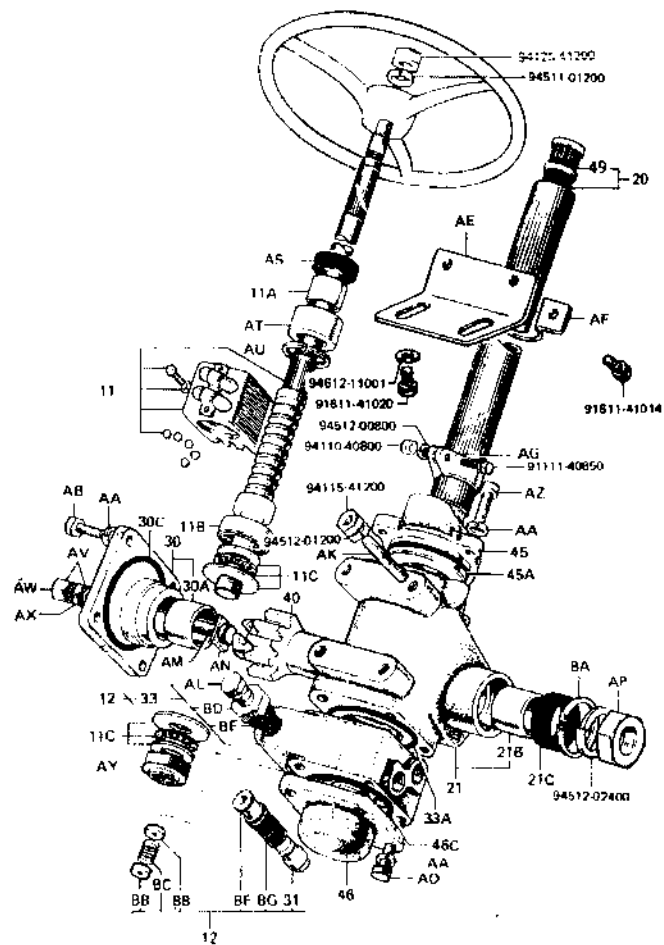
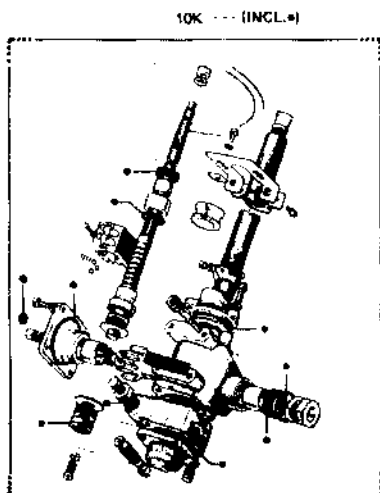
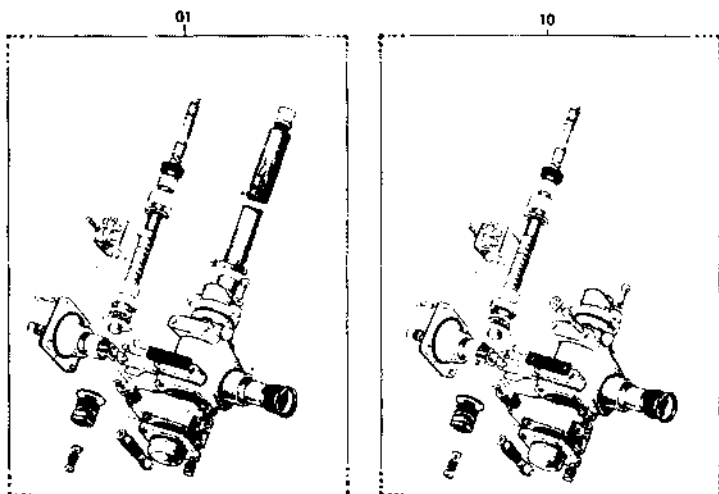

4502-019

4502-018

4502

PART NAME CODE	PART NAME	QTY
4502-01	POST ASSY, STEERING -----	1
4502-10	GEAR ASSY, STEERING -----	1
4502-10K	GEAR O/H KIT, STEERING -----	1
4502-11	BALL SCREW SET -----	1
4502-11A	BEARING, NO.1 (FOR BALL SCREW SET) -----	1
4502-11B	BEARING, NO.2 (FOR BALL SCREW SET) -----	1
4502-11C	BEARING, THRUST (FOR BALL SCREW SET) -----	2
4502-12	BODY ASSY, VALVE -----	1
4502-20	JACKET SUB-ASSY, MAST -----	1
4502-21	BOX SUB-ASSY, STEERING GEAR -----	1
4502-21B	BEARING, NO.1 (FOR SECTOR SHAFT) -----	1
4502-21C	SEAL, OIL (FOR SECTOR SHAFT) -----	1
4502-30	COVER SUB-ASSY, SIDE -----	1
4502-30A	BUSH, SECTOR SHAFT, NO.2 -----	1
4502-30C	RING, O (FOR SIDE COVER) -----	1
4502-31	VALVE SET, RELIEF -----	1
4502-33	BODY SET, VALVE -----	1
4502-33A	RING, O (FOR VALVE BODY SET) -----	2
4502-40	SHAFT, SECTOR -----	1
4502-45	COVER, TOP -----	1
4502-45A	RING, O (FOR TOP COVER) -----	1
4502-46	COVER, END -----	1
4502-46C	RING, O (FOR END COVER) -----	1
4502-49	GROMMET, STEERING COLUMN (INSULATOR) -----	1
4502-AA	WASHER, SPRING -----	11
4502-AB	BOLT -----	4
4502-AE	STAY SUB-ASSY, STEERING -----	1
4502-AF	CLAMP -----	1
4502-AG	CLAMP, STEERING COLUMN, LOWER -----	1
4502-AK	BOLT, STUD -----	4
4502-AL	PLUG, OIL -----	1
4502-AM	BOLT, ADJUSTING -----	1
4502-AN	PLATE, ADJUSTING -----	1
4502-AU	BOLT -----	4
4502-AP	NUT -----	1
4502-AS	SEAL, OIL -----	1
4502-AT	COLLAR -----	1
4502-AU	RING, SNAP -----	1
4502-AV	PACKING -----	2
4502-AW	NUT -----	1
4502-AX	NUT -----	1
4502-AY	NUT, LOCK -----	1
4502-AZ	BOLT -----	3
4502-BA	RING, SNAP -----	1
4502-BB	SEAT -----	8
4502-BC	SPRING -----	4
4502-BO	STOPPER, BALANCE PISTON -----	1
4502-BE	RING, O -----	1
4502-BF	VALVE SUB-ASSY, RELIEF -----	1
4502-BG	SPRING, BALANCE PISTON -----	1

FIG. 4507 DRAG LINK & STEERING PIPING

4507

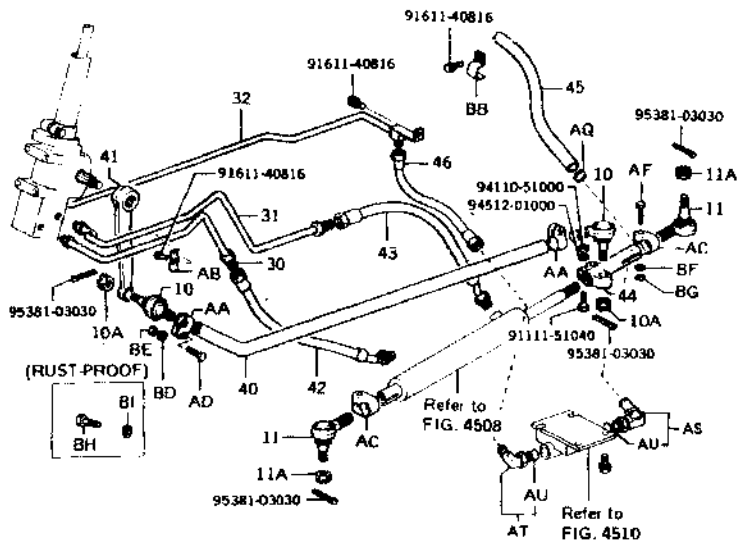

PART NAME CODE	PART NAME	QTY
4507-10	END ASSY, DRAG LINK -----	2
4507-10A	NUT, CASTLE (FOR DRAG LINK END) -----	2
4507-11	END ASSY, POWER CYLINDER -----	2
4507-11A	NUT, CASTLE (FOR POWER CYLINDER END) -----	2
4507-30	PIPE SUB-ASSY, NO.1 (STEERING TO CYLINDER) -	1
4507-31	PIPE SUB-ASSY, NO.2 (STEERING TO CYLINDER) -	1
4507-32	PIPE SUB-ASSY (PUMP TO STEERING) -----	1
4507-40	ROD, DRAG LINK, NO.1 -----	1
4507-41	ARM, PITMAN -----	1
4507-42	HOSE, POWER CYLINDER, NO.1 -----	1
4507-43	HOSE, POWER CYLINDER, NO.2 -----	1
4507-44	END, POWER CYLINDER -----	1
4507-45	HOSE, POWER STEERING PUMP SUCTION -----	1
4507-46	HOSE, HIGH PRESSURE (PUMP TO STEERING) -----	1
4507-AA	CLAMP, END -----	2
4507-AB	CLAMP, PIPE -----	1
4507-AC	CLAMP, END -----	2
4507-AD	BOLT -----	2
4507-AF	BOLT -----	2
4507-AQ	CLAMP -----	2
4507-AS	FITTING -----	1
4507-AT	FITTING -----	1
4507-AU	RING, O -----	2
4507-BB	CLAMP -----	1
4507-BD	WASHER, SPRING -----	2
4507-BE	NUT -----	2
4507-BF	WASHER, SPRING -----	2
4507-BG	NUT -----	2
4507-BH	BOLT, STAINLESS -----	1
4507-BI	WASHER -----	1

4507 006

FIG. 4508 STEERING POWER CYLINDER

4508

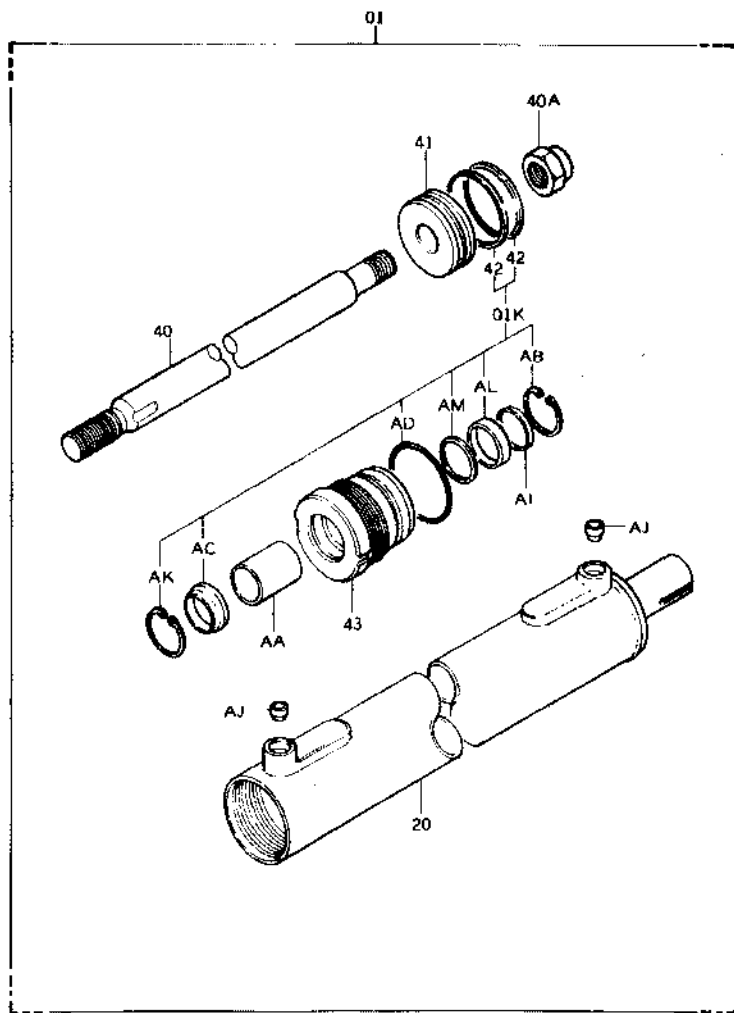

4508-007A

PART NAME CODE	PART NAME	QTY
4508-01	CYLINDER ASSY, POWER -----	1
4508-01K	PACKING KIT, POWER CYLINDER -----	1
4508-20	CYLINDER SUB-ASSY, POWER -----	1
4508-40	ROD, PISTON -----	1
4508-40A	NUT, SELF LOCK (FOR PISTON) -----	1
4508-41	PISTON -----	2
4508-42	RING, PISTON -----	1
4508-43	GUIDE, ROD -----	1
4508-AA	BUSHING -----	1
4508-AB	RING, SNAP -----	1
4508-AC	SEAL, DUST -----	1
4508-AD	RING, O -----	1
4508-AI	COLLAR, REAR COVER -----	1
4508-AJ	SEAL -----	2
4508-AK	RING, SNAP -----	1
4508-AL	PACKING, U -----	1
4508-AM	RING, BACK UP -----	1

FIG. 4510 STEERING OIL PUMP

4510

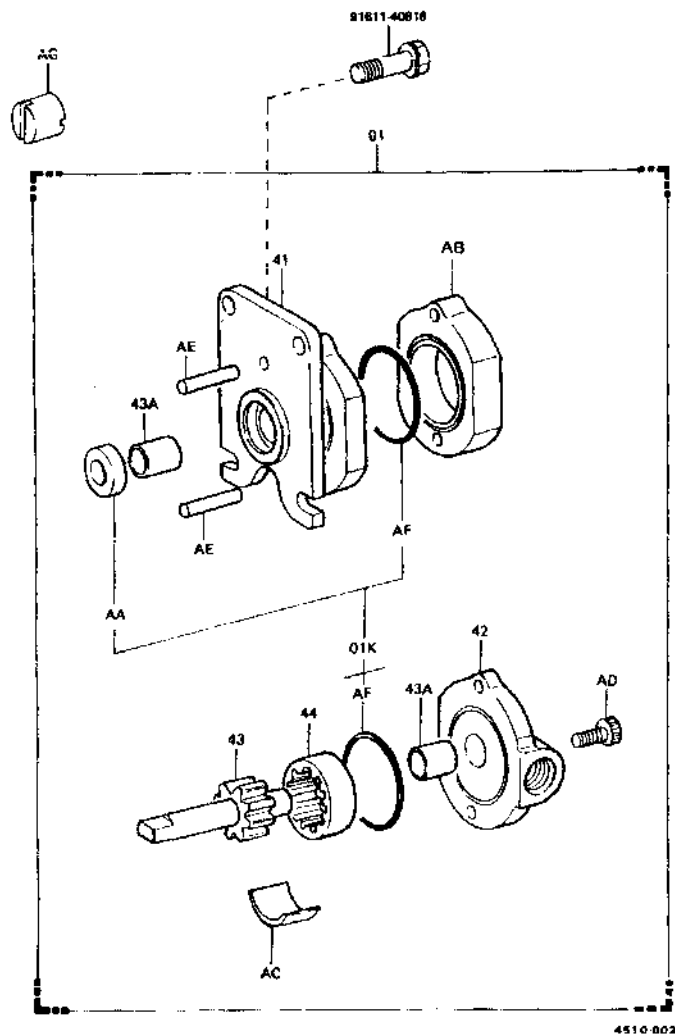

PART NAME CODE	PART NAME	QTY
4510-01	PUMP ASSY, POWER STEERING -----	1
4510-01K	PUMP KIT, POWER STEERING -----	1
4510-41	FLANGE, MOUNTING -----	1
4510-42	COVER -----	1
4510-43	SHAFT, PINION -----	1
4510-43A	BUSH (FOR PINION SHAFT) -----	2
4510-44	GEAR, INTERNAL -----	1
4510-AA	SEAL, OIL -----	1
4510-AB	HOUSING, OIL PUMP -----	1
4510-AC	SEGMENT -----	1
4510-AD	BOLT -----	4
4510-AE	PIN -----	1
4510-AF	RING, O -----	2
4510-AG	JOINT, OLDHAM -----	1

FIG. 4601 PARKING BRAKE

4601

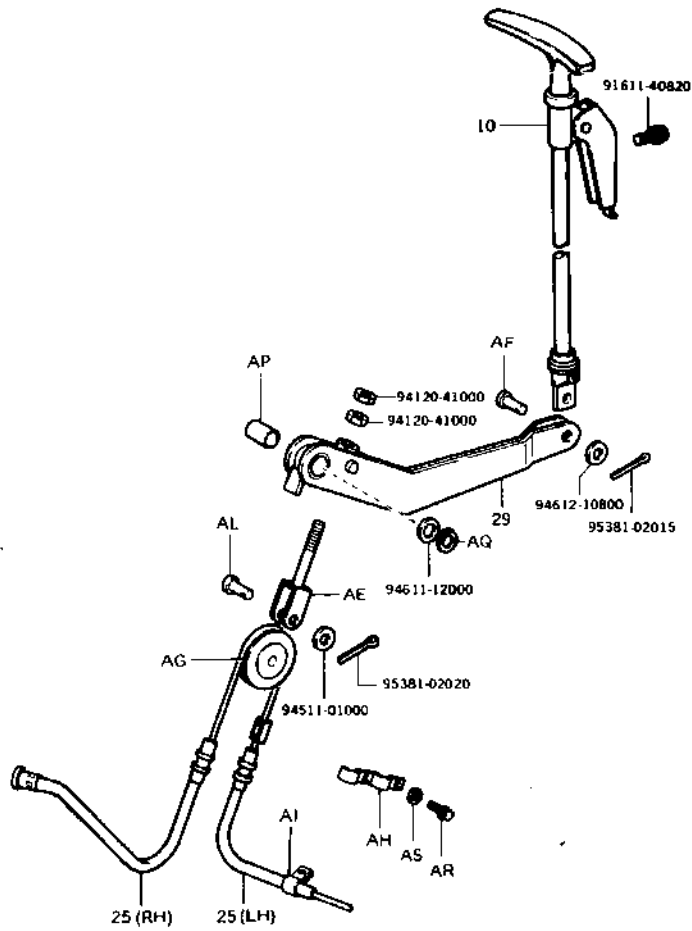

4601 008

PART NAME CODE	PART NAME	QTY
4601-10	HANDLE ASSY, PARKING BRAKE -----	1
4601-25	CABLE SUB-ASSY, PARKING BRAKE, NO.2 -----	1
4601-29	LEVER SUB-ASSY, INTERMEDIATE -----	1
4601-AE	BAR SUB-ASSY, EQUALIZER -----	1
4601-AF	PIN, W/HOLE -----	1
4601-AG	PULLEY -----	1
4601-AH	CLAMP, WIRE SET -----	1
4601-AI	CLAMP -----	1
4601-AL	PIN, W/HOLE -----	1
4601-AP	BUSHING -----	1
4601-AQ	RING, SNAP -----	1
4601-AR	BOLT -----	2
4601-AS	WASHER, SPRING -----	2

FIG 4602 DEAD-MAN BRAKE

4602

(UL-E, UL-EE)

(UL-E, UL-EE)

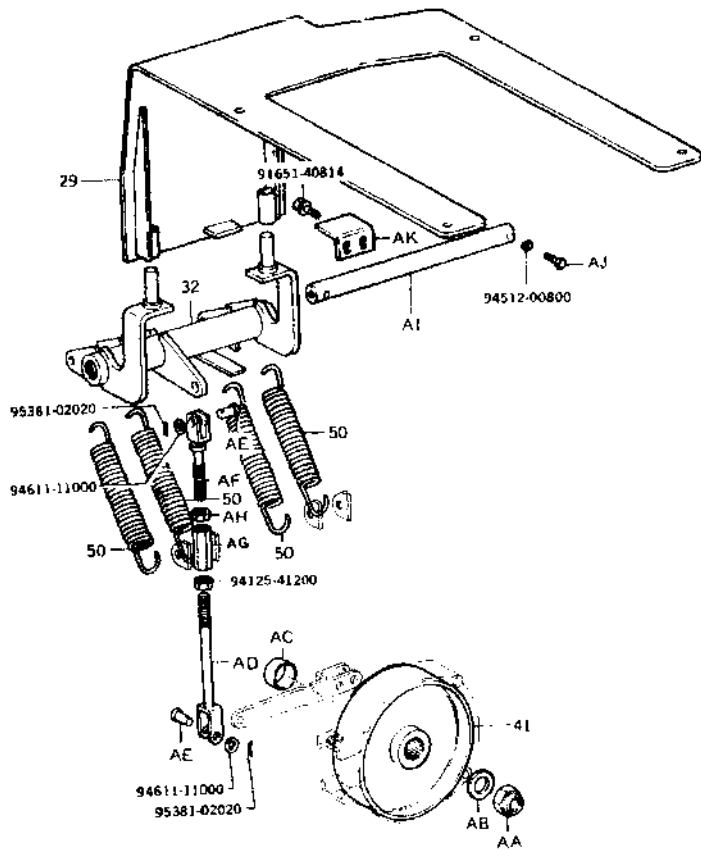

4602 002

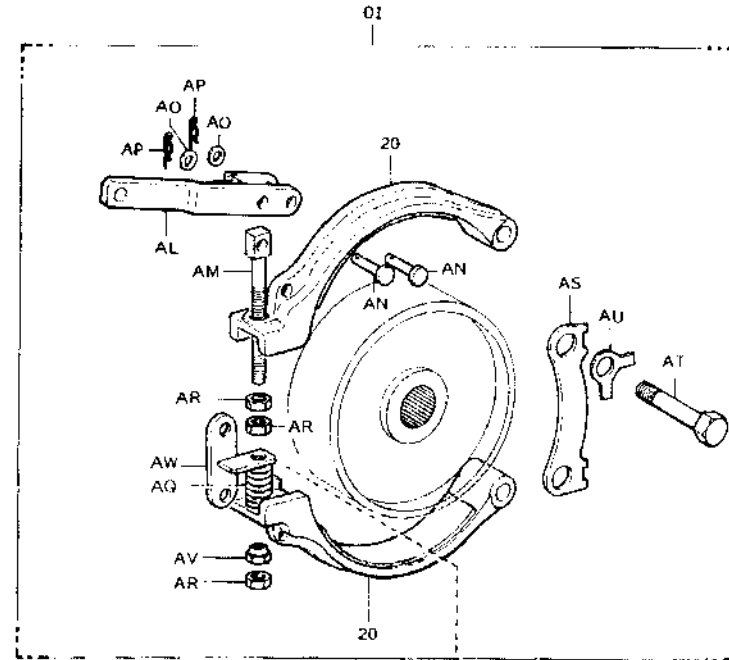

4602 001

4602

PART NAME CODE	PART NAME	QTY
4602-01	BRAKE ASSY, DEAD-MAN -----	1
4602-20	SHOE SUB-ASSY, BRAKE -----	2
4602-29	FRAME SUB-ASSY, SEAT -----	1
4602-32	LINK SUB-ASSY, DEAD-MAN BRAKE -----	1
4602-41	DRUM, DEAD-MAN BRAKE -----	1
4602-50	SPRING, BRAKE LINK -----	4
4602-AA	NUT, SELF LOCK -----	1
4602-AB	WASHER, PLATE -----	1
4602-AC	COLLAR -----	1
4602-AD	ROD SUB-ASSY, DEAD MAN BRAKE -----	1
4602-AE	PIN, W/HOLE -----	2
4602-AF	ROD SUB-ASSY, CONTROL VALVE -----	1
4602-AG	TURNBUCKLE -----	1
4602-AH	NUT -----	1
4602-AI	SHAFT -----	1
4602-AJ	BOLT -----	1
4602-AK	PLATE, SEAT FRAME STOPPER -----	1
4602-AL	LEVER ASSY, BRAKE -----	1
4602-AM	STRUT -----	1
4602-AN	PIN, BRAKE LEVER -----	2
4602-AO	WASHER, PLATE -----	2
4602-AP	PIN, SNAP -----	2
4602-AQ	SPRING, SHOE RETURN -----	1
4602-AR	NUT -----	3
4602-AS	PLATE, GUIDE -----	1
4602-AT	STUD -----	2
4602-AU	WASHER, LOCK -----	2
4602-AV	NUT, STRUT -----	1
4602-AW	BRACKET -----	1

FIG. 4701 BRAKE PEDAL

4701

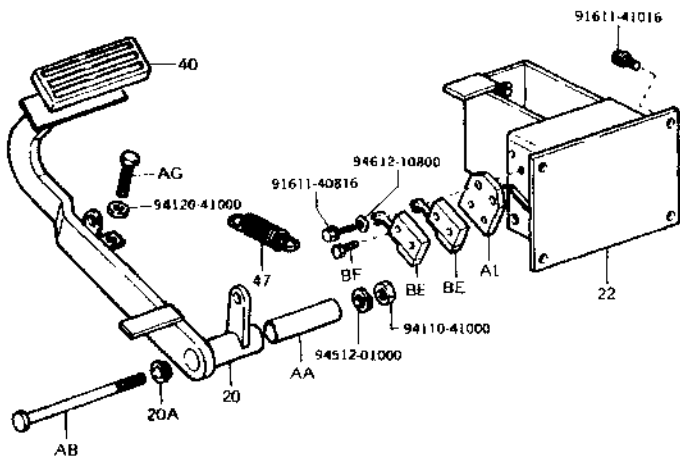
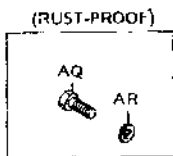
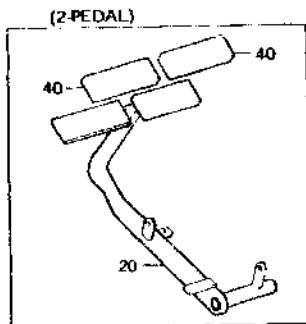

4701-021

PART NAME CODE	PART NAME	QTY
4701-20	PEDAL SUB-ASSY, BRAKE	1
4701-20A	BUSH (FOR BRAKE PEDAL)	2
4701-22	BRACKET SUB-ASSY, BRAKE PEDAL	1
4701-40	PAD, PEDAL	1
4701-47	SPRING, TENSION (FOR PEDAL RETURN)	1
4701-AA	SPACER	1
4701-AB	BOLT	1
4701-AG	BOLT, ADJUST	1
4701-AL	BRACKET, STOP SWITCH	1
4701-AQ	BOLT, STAINLESS	4
4701-AR	WASHER, SPRING	4
4701-BE	SWITCH ASSY, LIMIT	1
4701-BF	SCREW	1

FIG. 4702 BRAKE MASTER CYLINDER

4702

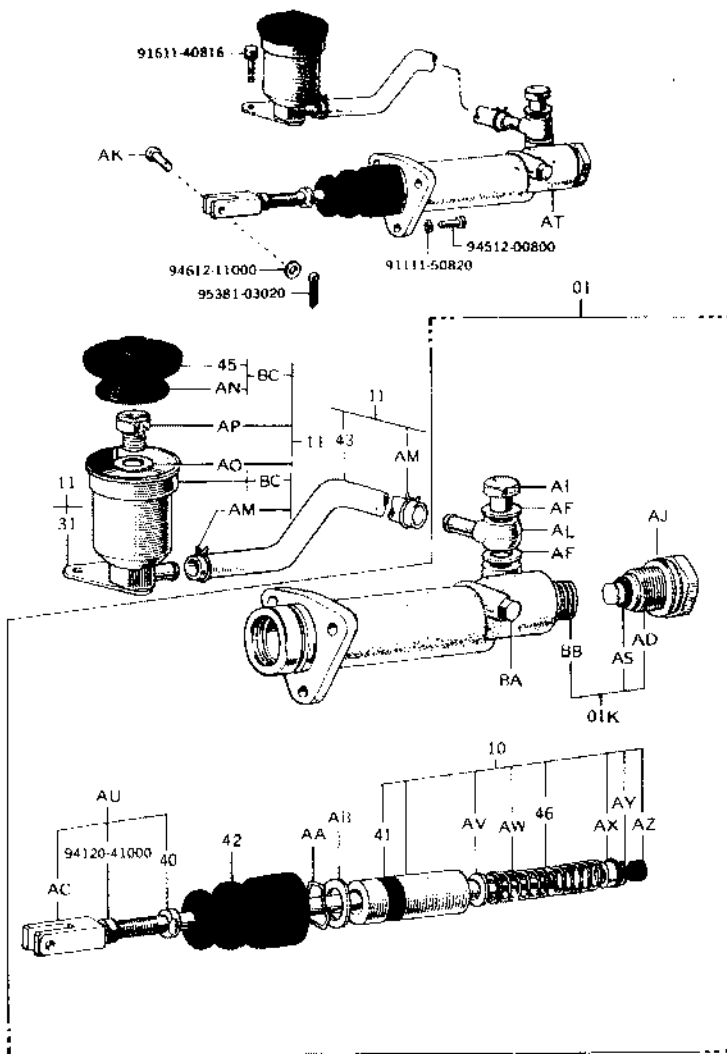

PART NAME CODE	PART NAME	QTY
4702-01K	CYLINDER O/H KIT, MASTER	1
4702-10	PISTON SUB-ASSY, MASTER CYLINDER	1
4702-11	RESERVOIR SET, MASTER CYLINDER	1
4702-31	BRACKET SUB-ASSY, RESERVOIR	1
4702-40	ROD, PUSH	1
4702-41	CUP, CYLINDER	1
4702-42	BOOT	1
4702-43	HOSE, RESERVOIR	1
4702-45	CAP, RESERVOIR	1
4702-46	SPRING, COMPRESSION (FOR PISTON RETURN)	1
4702-AA	RING, HOLE SNAP	1
4702-AB	PLATE, PISTON STOP	1
4702-AC	CLEVIS, PUSH ROD	1
4702-AD	CAP, BREATHER PLUG	1
4702-AF	GASKET	2
4702-AI	BOLT, UNION	1
4702-AJ	GASKET	1
4702-AK	PIN	1
4702-AL	UNION	1
4702-AM	CLAMP	2
4702-AN	FLOAT	1
4702-AO	WASHER	1
4702-AP	BOLT	1
4702-AS	SEAT	1
4702-AT	CYLINDER ASSY, MASTER W/RESERVOIR	1
4702-AU	ROD SUB-ASSY MASTER CYLINDER PUSH	1
4702-AV	RETAINER	1
4702-AW	ROD, CONNECTING	1
4702-AX	RETAINER	1
4702-AY	SPRING, CONICAL	1
4702-AZ	SEAL, VALVE	1
4702-BA	PLUG	1
4702-BB	SPRING, COMPRESSION	1
4702-BC	RESERVOIR, MASTER CYLINDER	1

FIG. 4714 BRAKE PIPE

4714

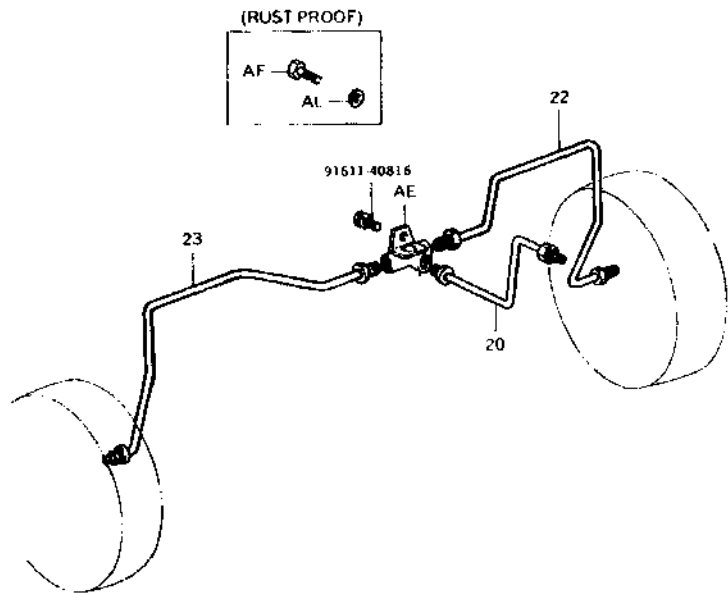

4714 009

PART NAME CODE	PART NAME	QTY
4714-20	PIPE SUB-ASSY, BRAKE, MAIN NO.1	1
4714-22	PIPE SUB-ASSY, BRAKE, RH NO.1	1
4714-23	PIPE SUB-ASSY, BRAKE, LH NO.1	1
4714-AE	3-WAY SUB-ASSY	1
4714-AF	BOLT	1
4714-AL	WASHER, SPRING	1

(MAIN) (29)

G210

FIG 4715 DRUM BRAKE

4715

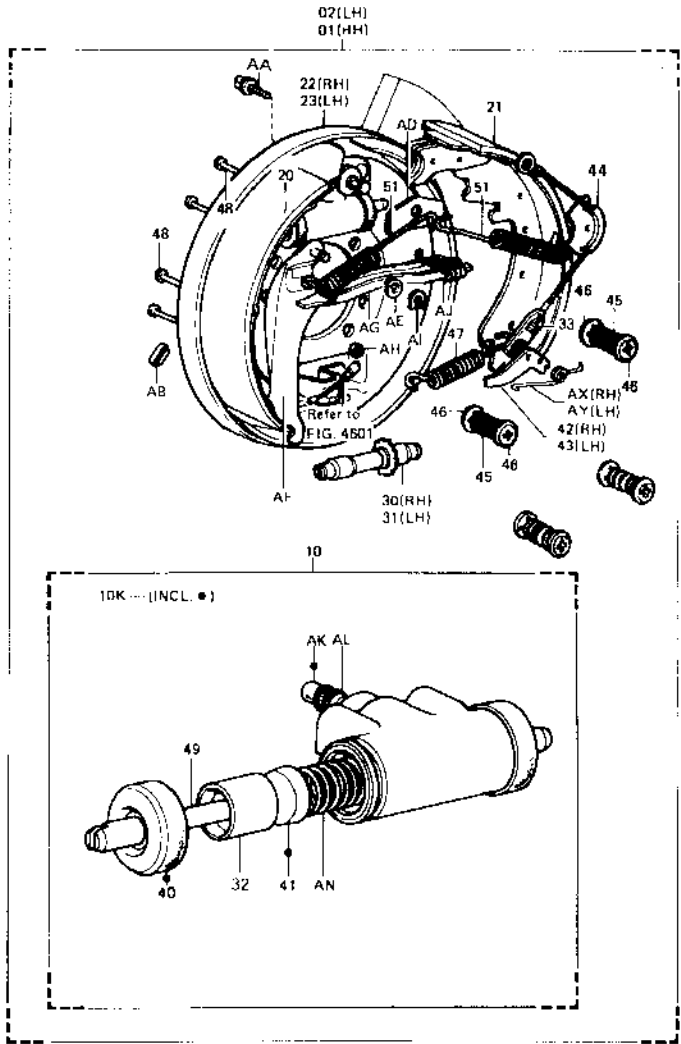

PART NAME CODE	PART NAME	QTY
4715-01	BRAKE ASSY, RH	1
4715-02	BRAKE ASSY, LH	1
4715-10	CYLINDER ASSY, WHEEL	2
4715-10K	CYLINDER O/H KIT, WHEEL	2
4715-20	SHOE SUB-ASSY (FOR FRONT OR UPPER)	2
4715-21	SHOE SUB-ASSY (FOR REAR OR LOWER)	2
4715-22	PLATE SUB-ASSY, BACKING, RH	1
4715-23	PLATE SUB-ASSY, JACKING, LH	1
4715-30	SCREW SUB-ASSY, ADJUSTING, RH	1
4715-31	SCREW SUB-ASSY, ADJUSTING, LH	1
4715-32	PISTON SUB-ASSY, WHEEL CYLINDER	4
4715-33	CABLE & FITTING SUB-ASSY	2
4715-40	BOGT, WHEEL CYLINDER	4
4715-41	CUP, WHEEL CYLINDER PISTON	4
4715-42	LEVER, AUTOMATIC ADJUSTMENT, RH	1
4715-43	LEVER, AUTOMATIC ADJUSTMENT, LH	1
4715-44	GUIDE, CABLE	2
4715-45	SPRING, SHOE HOLD DOWN	8
4715-46	CUP, SHOE HOLD DOWN	16
4715-47	SPRING, ADJUSTER	2
4715-48	PIN, SHOE HOLD DOWN	8
4715-49	ROD, PUSH	4
4715-51	SPRING, ANCHOR TO SHOE	4
4715-AA	BOLT & WASHER SET	4
4715-AB	COVER, HOLE	2
4715-AD	PLATE, SHOE GUIDE	2
4715-AE	WASHER, SPRING	2
4715-AF	LEVER SUB-ASSY, PARKING	1
4715-AG	STRUT, LEVER	1
4715-AH	RING, SNAP	2
4715-AI	RETAINER	2
4715-AJ	SPRING, STRUT TO SHOE	2
4715-AK	CAP, BREATHER SCREW	2
4715-AL	SCREW, BREATHER	2
4715-AN	SPRING, WHEEL CYLINDER	2
4715-AX	SPRING, LEVER RETURN, RH	1
4715-AY	SPRING, LEVER RETURN, LH	1

FIG. 5101 FRAME & WEIGHT

5101

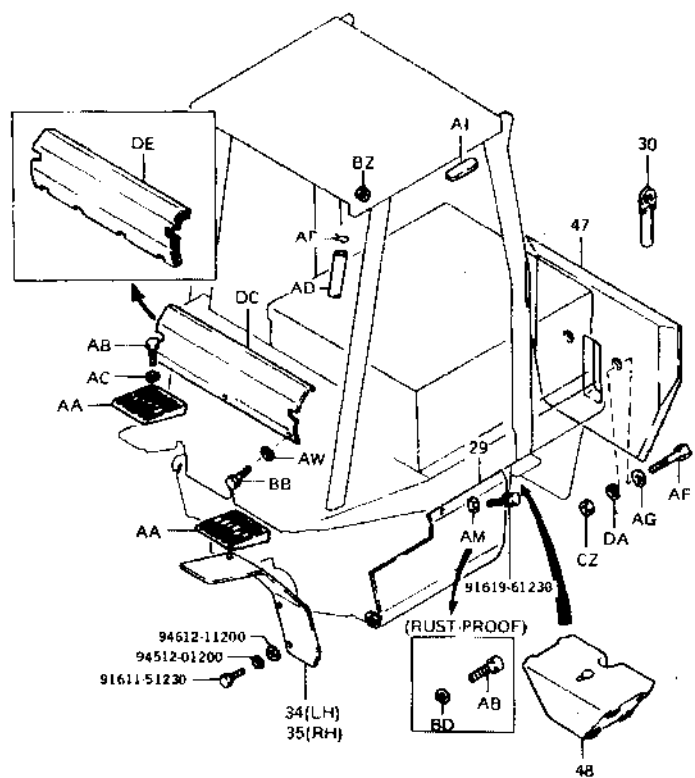

PART NAME CODE	PART NAME	QTY
5101-29	COVER SUB-ASSY, BATTERY	1
5101-30	DRAW-BAR SUB-ASSY	1
5101-34	GUARD SUB-ASSY, MUD, RH	1
5101-35	GUARD SUB-ASSY, MUD, LH	1
5101-47	WEIGHT SUB-ASSY, NO.1	1
5101-48	WEIGHT SUB-ASSY, NO.2	1
5101-AA	GUARD, MUD, FRONT	2
5101-AB	BOLT	4
5101-AC	WASHER, WAVE	4
5101-AD	HOSE, LOW PRESSURE	2
5101-AE	CLAMP SUB-ASSY	2
5101-AF	BOLT, HEXAGON	1
5101-AG	PLATE, WASHER	1
5101-AI	SPONGE	1
5101-AM	WASHER, PLATE	2
5101-AN	WASHER, PLATE	10
5101-AB	BOLT	10
5101-BD	WASHER, PLATE	2
5101-BZ	GROMMET	1
5101-CZ	NUT	2
5101-OA	WASHER	2
5101-DC	PLATE, COVER	1
5101-DE	SEAL, COVER	1

5101-013

FIG 5201 HOOD & HINGE

5201

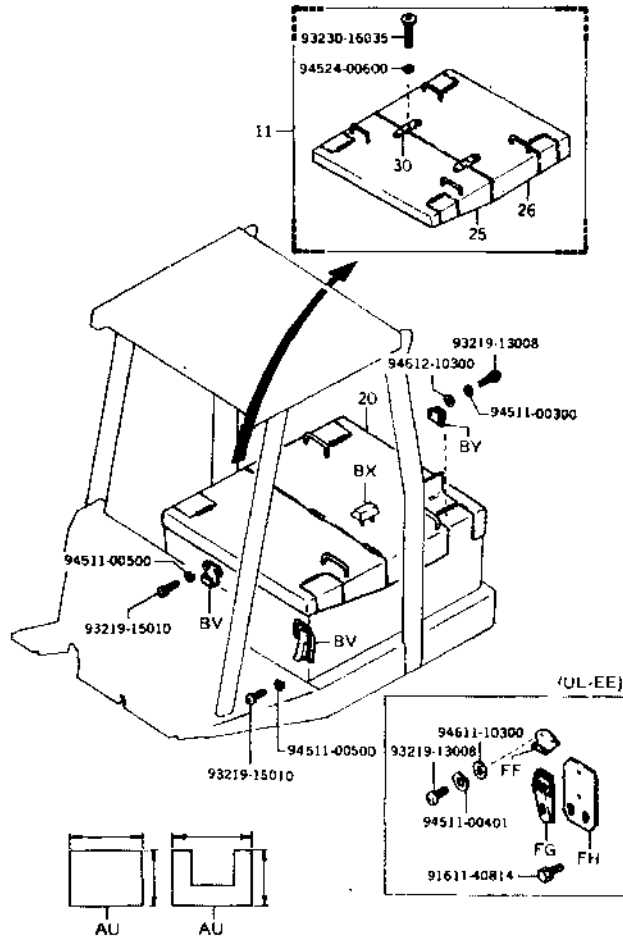

PART NAME CODE	PART NAME	QTY
5201-11	HOOD ASSY, BATTERY	1
5201-25	HOOD SUB ASSY, BATTERY, FRONT	1
5201-26	HOOD SUB-ASSY, BATTERY, REAR	1
5201-30	HINGE SUB-ASSY, BATTERY HOOD	2
5201-AU	INSULATOR	1
5201-BV	HOLDER	4
5201-BX	BOLT	2
5201-BY	WASHER, SPRING	4
5201-CW	SUPPORT, HOOD STAY	1
5201-FF	LATCH	4
5201-FG	LATCH	4
5201-FH	PLATE	4

5201 014

FIG. 5301 INSTRUMENT PANEL & FLOOR

5301

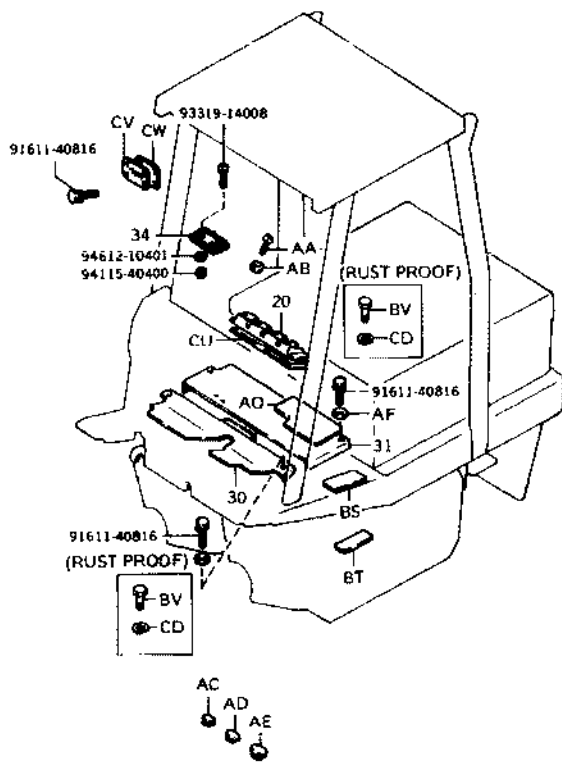

PART NAME CODE	PART NAME	QTY
5301-20	PANEL SUB-ASSY, INSTRUMENT -----	1
5301-30	TOE-BOARD SUB-ASSY, NO.1 -----	1
5301-31	TOE-BOARD SUB-ASSY, NO.2 -----	1
5301-34	CLAMP SUB-ASSY, PAPER -----	1
5301-AA	SCREW -----	4
5301-AB	WASHER, WAVE -----	4
5301-AC	PLUG -----	1
5301-AD	PLUG -----	2
5301-AE	PLUG -----	1
5301-AF	WASHER, PLATE -----	4
5301-AO	SAFETY WALK -----	1
5301-BS	SAFETY WALK -----	1
5301-BI	SAFETY WALK -----	1
5301-BV	BOLT -----	4
5301-CD	WASHER, SPRING -----	4
5301-CU	RUBBER -----	1
5301-CV	PLATE -----	1
5301-CW	RUBBER -----	1

5301 021

FIG. 5308 DRIVER SEAT

5308

(W/ABSORBER)

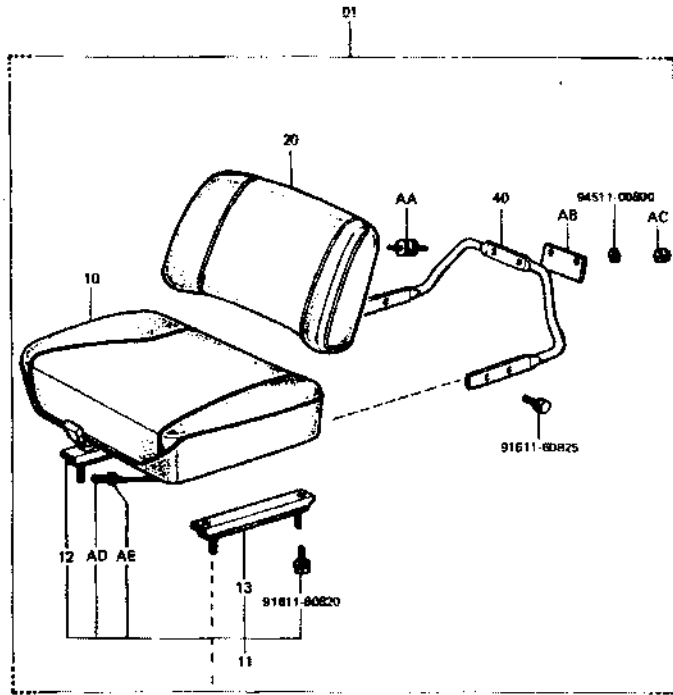

94512-00800
94170-40800

5308-014

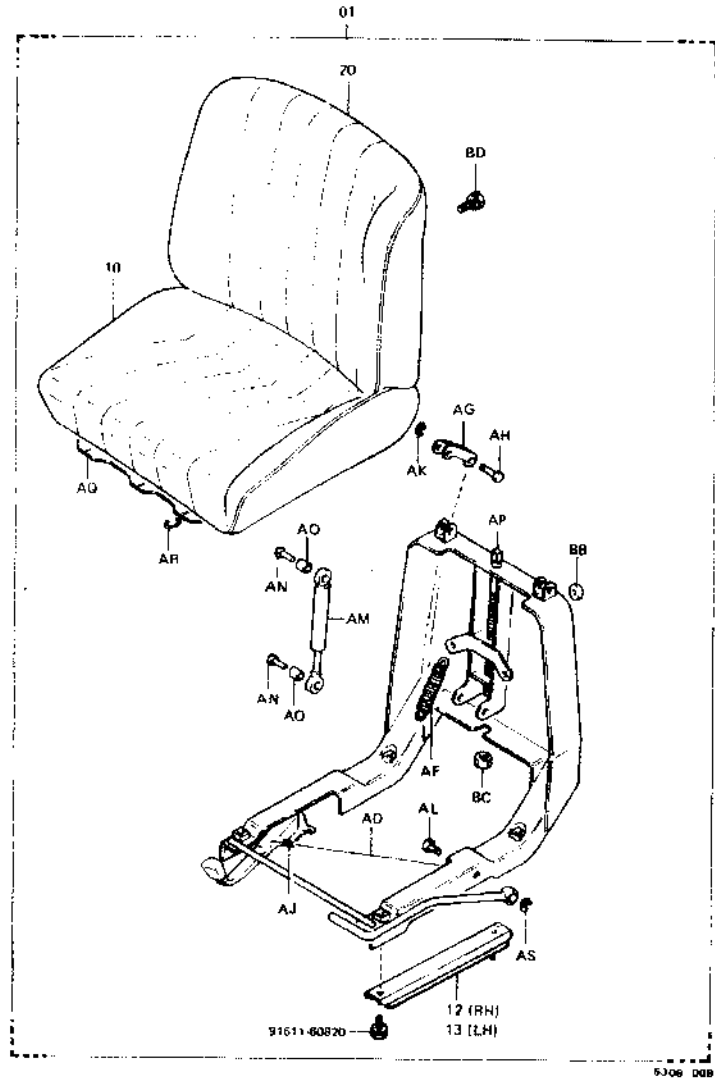

5308 008

5308

PART NAME CODE	PART NAME	QTY
5308-01	SEAT ASSY -----	1
5308-10	CUSHION ASSY -----	1
5308-11	TRACK ASSY -----	1
5308-12	TRACK ASSY, SEAT OUTER, RH -----	1
5308-13	TRACK ASSY, SEAT OUTER, LH -----	1
5308-20	SEAT SUB-ASSY, BACK -----	1
5308-40	FRAME, BACK SEAT -----	1
5308-AA	RUBBER, VIBRATION ISOLATOR -----	2
5308-AB	BRACKET, NUMBER PLATE -----	1
5308-AC	NUT, CAP -----	2
5308-AD	WIRE -----	1
5308-AE	WASHER -----	2
5308-AF	SPRING, TENSION, BACK SEAT -----	2
5308-AG	LINK -----	2
5308-AH	PIN -----	4
5308-AJ	COIL, SPRING -----	2
5308-AK	E-RING -----	4
5308-AL	PIN, NO.2 -----	2
5308-AM	SHOCK ABSORBER -----	1
5308-AP	ADJUSTER, ROD -----	1
5308-AR	HOOK, SEAT CUSHION -----	10
5308-AS	RING, E -----	2
5308-8B	CUSHION -----	1
5308-BC	NUT, STOPPER -----	1
5308-BD	BOLT, W/WASHER -----	4

FIG. 5401 HEAD GUARD & ACCESSORY

5401

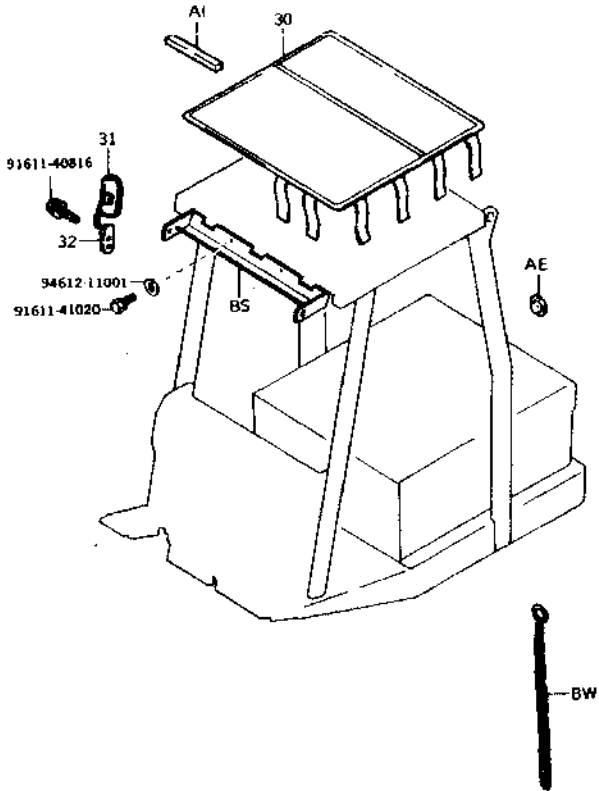

5401-022

PART NAME CODE	PART NAME	QTY
5401-30	SHEET SUB-ASSY, HEAD GUARD -----	1
5401-31	MIRROR SUB-ASSY, BACK -----	1
5401-32	BRACKET SUB-ASSY, BACK MIRROR -----	2
5401-AE	PLUG, HOLE -----	1
5401-AI	CUSHION, SEAT -----	2
5401-BS	PLATE SUB-ASSY, HEAD GUARD -----	1
5401-BW	CHAIN SUB-ASSY, DRAG -----	1

FIG. 5405 INDICATOR PLATE

5405

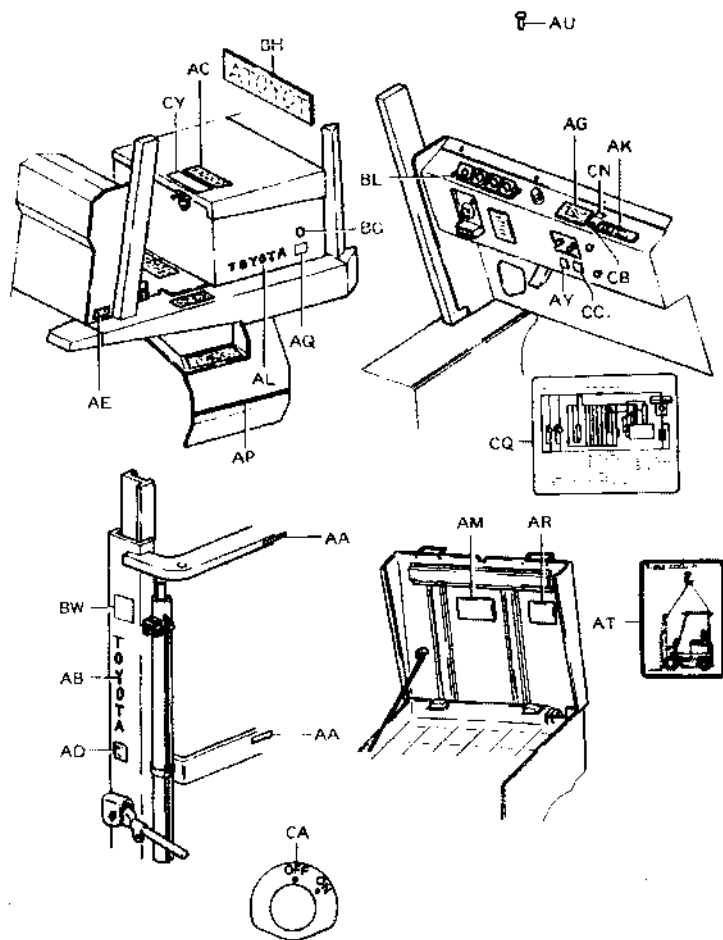

5405-01B

PART NAME CODE	PART NAME	QTY
5405-AA	PLATE, CAUTION -----	2
5405-AC	PLATE, CAUTION -----	1
5405-AD	PLATE, CAUTION -----	2
5405-AE	PLATE, INDICATOR -----	1
5405-AG	PLATE, LOAD INDICATOR -----	1
5405-AK	PLATE, INDICATOR -----	1
5405-AL	TOYOTA MARK -----	1
5405-AM	PLATE, SERVICE INDICATOR -----	1
5405-AP	STRIPE -----	2
5405-AQ	PLATE, CAPACITY INDICATOR -----	2
5405-AR	PLATE, CAUTION -----	1
5405-AT	PLATE, CAUTION -----	1
5405-AU	RIVET -----	4
5405-BG	PLATE, TEMPERATURE -----	2
5405-BH	MARK, TOYOTA -----	2
5405-BW	MARK, SYMBOL -----	2
5405-CA	PLATE, CAUTION -----	1
5405-CB	PLATE, INDICATOR -----	1
5405-CC	PLATE, CAUTION -----	1
5405-CN	PLATE, INDICATOR -----	1
5405-CQ	PLATE, SEQUENCE DIAGRAM -----	1
5405-CY	PLATE, CAUTION -----	1

FIG. 5502 CANVAS CABIN & FRONT GLASS

5502

(FRONT GLASS)

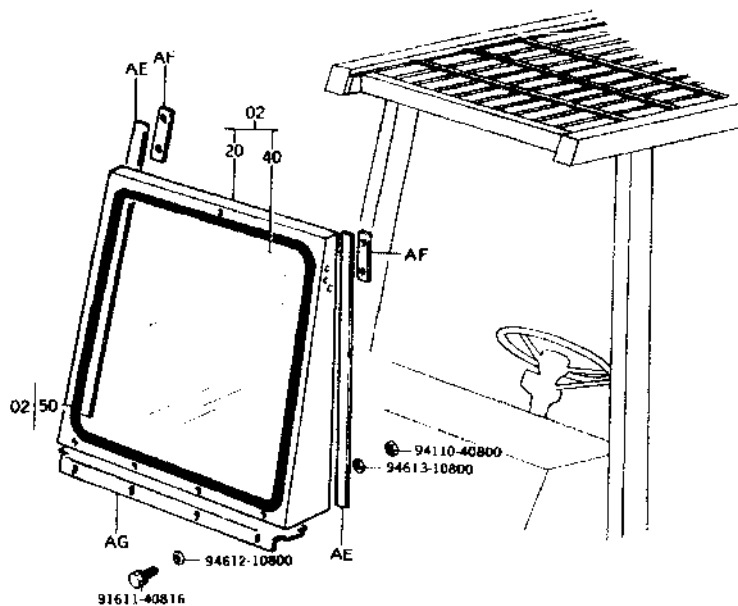

PART NAME CODE	PART NAME	QTY
5502-02	PANEL ASSY, FRONT GLASS -----	1
5502-20	PANEL SUB-ASSY, FRONT GLASS -----	1
5502-40	GLASS, WINDSHIELD -----	1
5502-50	WEATHER STRIP -----	1
5502-AE	CUSHION, WINDSHIELD -----	2
5502-AF	PLATE, WINDSHIELD -----	2
5502-AG	PLATE, FRONT -----	1

5502-006

FIG. 5602 WIRING & CLAMP

5602

(UL-EE)

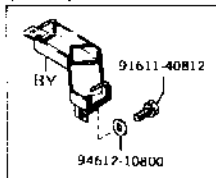

(UL EE)

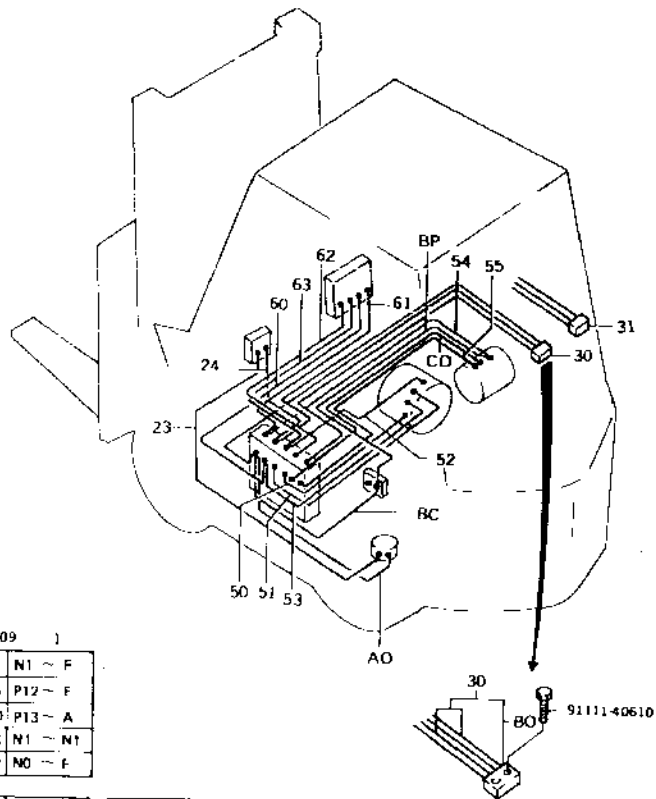
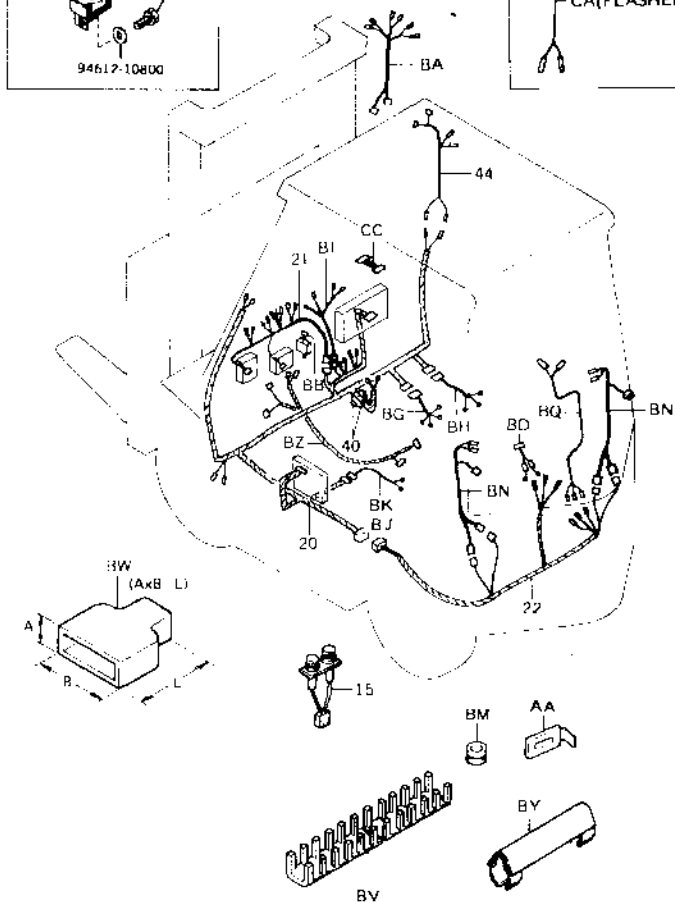
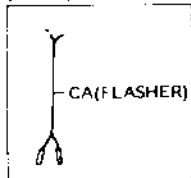

(B209)

54	N1 ~ F
55	P12 ~ F
CD	P13 ~ A
BC	N1 ~ N1
BP	N0 ~ F

23	P22 ~ AC
24	P1 ~ P1
50	P3 ~ F
51	P4 ~ E
52	P5 ~ A
53	P6 ~ B
54	N1 ~ F D
55	P12 ~ AC

60	P6 ~ P8
61	N1 ~ N1
62	P2 ~ P2
63	P5 ~ P5
AO	N1 ~ BD
BC	N0 ~ N1
BP	N0 ~ F D

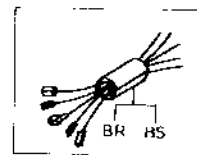

5602-028

5602 02

5602

PART NAME CODE	PART NAME	QTY
5602-15	FUSE ASSY -----	1
5602-20	HARNESS SUB-ASSY, WIRING -----	1
5602-21	HARNESS SUB-ASSY, PANEL -----	1
5602-22	HARNESS SUB-ASSY, RR -----	1
5602-23	WIRING SUB-ASSY, POWER STEERING -----	1
5602-24	WIRING SUB-ASSY, POWER STEERING -----	1
5602-30	CONNECTOR SUB-ASSY -----	1
5602-31	CONNECTOR SUB-ASSY, BATTERY -----	1
5602-40	FUSE -----	2
5602-44	CORO, HEAD LAMP -----	2
5602-50	WIRING, DRIVE MOTOR, NO.1 -----	1
5602-51	WIRING, DRIVE MOTOR, NO.2 -----	1
5602-52	WIRING, DRIVE MOTOR, NO.3 -----	1
5602-53	WIRING, DRIVE MOTOR, NO.4 -----	1
5602-54	WIRING, PUMP MOTOR, NO.1 -----	1
5602-55	WIRING, PUMP MOTOR, NO.2 -----	1
5602-60	WIRING, CONTROLLER, NO.1 -----	1
5602-61	WIRING, CONTROLLER, NO.2 -----	1
5602-62	WIRING, CONTROLLER, NO.3 -----	1
5602-63	WIRING, CONTROLLER, NO.3 -----	1
5602-AA	CLAMP -----	6
5602-AO	HARNESS, POWER STEERING -----	1
5602-BA	HARNESS ASSY -----	2
5602-BB	HARNESS, LIMIT SWITCH -----	1
5602-BC	WIRING SUB-ASSY, BREAKER -----	1
5602-BO	HARNESS, DIODE, ROTARY LAMP -----	1
5602-BH	HARNESS, SIDE BRAKE SWITCH -----	1
5602-BI	HARNESS ASSY, DIRECTION -----	1
5602-BJ	HARNESS, STOP LAMP SWITCH -----	1
5602-BK	HARNESS, BRAKE SWITCH -----	1
5602-BM	GROMMET -----	3
5602-BN	HARNESS ASSY, REAR COMBINATION -----	1
5602-BP	WIRING SUB-ASSY, PUMP MOTOR -----	1
5602-BQ	HARNESS, ROTARY LAMP -----	1
5602-BS	RUBBER, CABLE, NO.2 -----	1
5602-BV	BUSH -----	2
5602-BW	BOOT -----	99
5602-BY	COVER SUB-ASSY, HARNESS -----	1
5602-CA	HARNESS, FLASHER LAMP -----	2
5602-CC	HARNESS ASSY, CONTACTOR -----	1
5602-CD	WIRING SUB-ASSY, PUMP MOTOR -----	1

FIG. 5611 LAMP

5611

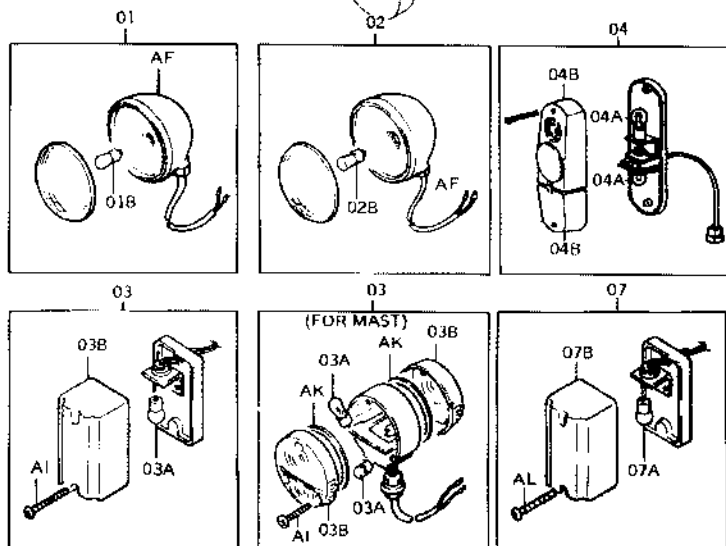
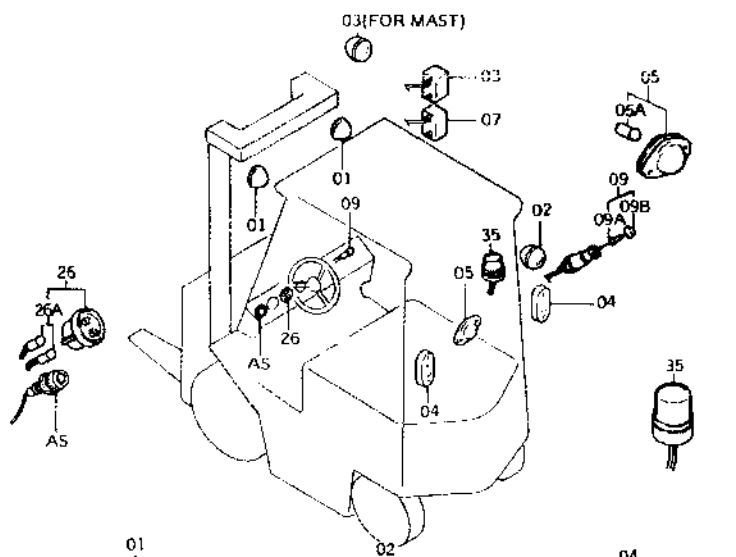

PART NAME CODE	PART NAME	QTY
5611-01	LAMP ASSY, HEAD -----	2
5611-01a	BULB (FOR HEAD LAMP) -----	2
5611-02	LAMP ASSY, WORKING -----	1
5611-02b	BULB (FOR WORKING LAMP) -----	1
5611-03	LAMP ASSY, FLASHER -----	2
5611-03a	BULB (FOR FLASHER LAMP) -----	2
5611-03b	LENS (FOR FLASHER LAMP) -----	2
5611-04	LAMP ASSY, REAR COMBINATION -----	2
5611-04a	BULB (FOR REAR COMBINATION LAMP) -----	2
5611-04b	LENS (FOR REAR COMBINATION LAMP) -----	2
5611-05	LAMP ASSY, LICENCE -----	1
5611-05a	BULB (FOR LICENCE LAMP) -----	1
5611-07	LAMP ASSY, CLEARANCE -----	2
5611-07a	BULB (FOR CLEARANCE LAMP) -----	2
5611-07b	LENS (FOR CLEARANCE LAMP) -----	2
5611-09	LAMP ASSY, PILOT -----	1
5611-09a	BULB (FOR PILOT LAMP) -----	1
5611-09b	LENS (FOR PILOT LAMP) -----	1
5611-26	LAMP ASSY, COMBINATION PILOT -----	1
5611-26a	BULB (FOR COMBINATION PILOT LAMP) -----	2
5611-35	LAMP ASSY, ROTARY -----	1
5611-AF	CORD, HEAD LAMP -----	3
5611-AI	SCREW -----	4
5611-AK	PACKING -----	4
5611-AL	SCREW -----	4
5611-AS	LAMP ASSY, PILOT -----	1

FIG. 5612 LAMP BRACKET

5612

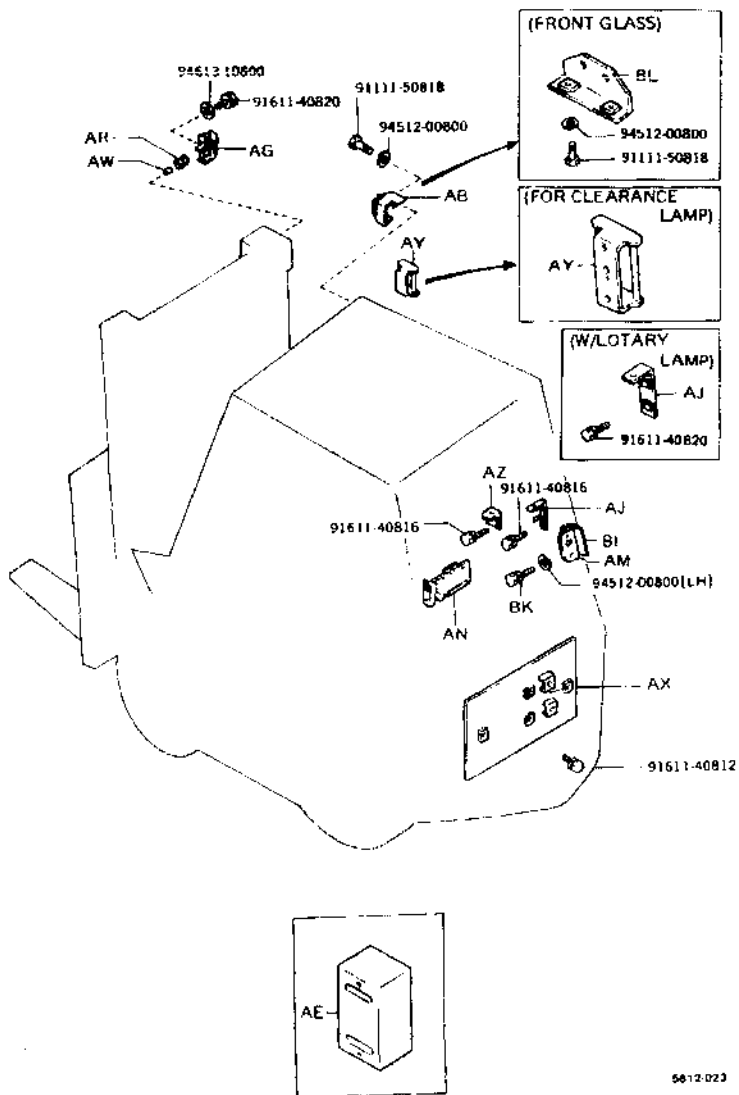

PART NAME CODE	PART NAME	QTY
5612-AB	BRACKET SUB-ASSY, HEAD LAMP -----	1
5612-AG	BRACKET, FLASHER LAMP -----	1
5612-AJ	BRACKET, WORKING LAMP -----	1
5612-AM	BRACKET, REAR COMBINATION LAMP -----	1
5612-AN	PLATE SUB-ASSY, LICENCE -----	1
5612-AR	WASHER, RUBBER -----	4
5612-AW	COLLER -----	4
5612-AX	PLATE SUB-ASSY, REAR OPTIUN -----	1
5612-AY	GUARD SUB-ASSY, LAMP -----	2
5612-AZ	BRACKET SUB-ASSY, ROTARY LAMP -----	1
5612-BI	PLATE, GUM -----	2
5612-BK	BOLT -----	2
5612-BL	PLATE SUB-ASSY, HEAD LAMP -----	1

FIG. 5702 METER & SWITCH

5702

(UL-EE)

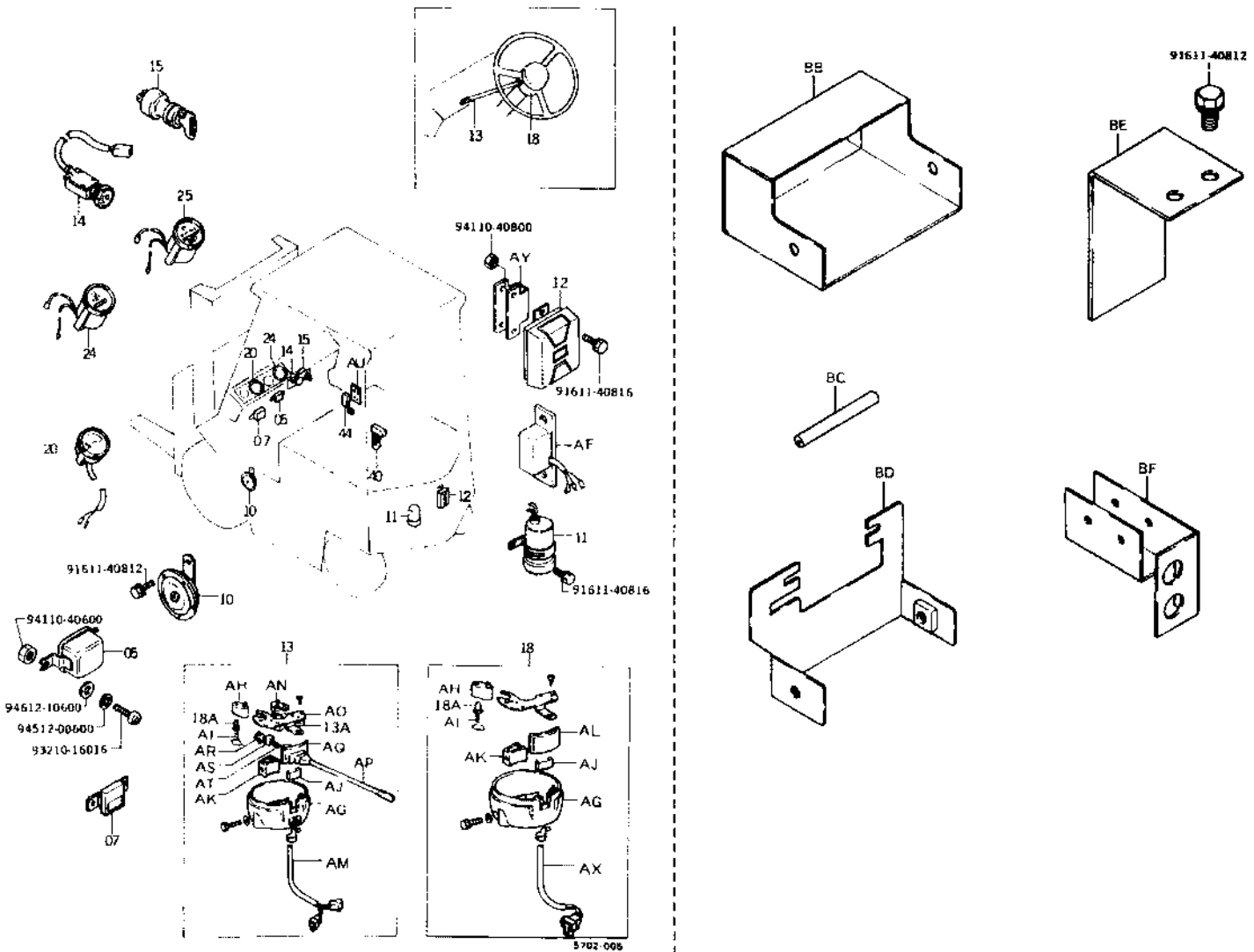

5702-006

5702

PART NAME CODE	PART NAME	QTY
5702-05	RELAY ASSY, FLASHER -----	1
5702-07	BOX ASSY, OVER DISCHARGE -----	1
5702-10	HORN ASSY -----	1
5702-11	BUZZER ASSY, BACK -----	1
5702-12	CHIME ASSY, BACK -----	2
5702-13	SWITCH ASSY, TURN SIGNAL -----	1
5702-13A	SWITCH SUB-ASSY, MICRO -----	2
5702-14	SWITCH ASSY, LIGHT CONTROL -----	1
5702-15	SWITCH ASSY, STARTER -----	1
5702-18	SWITCH ASSY, HORN -----	1
5702-18A	CONTACT, HORN -----	1
5702-20	METER ASSY, VOLTAGE -----	1
5702-24	METER ASSY, HOUR -----	1
5702-25	INDICATOR ASSY, BATTERY CAPACITY -----	1
5702-40	SWITCH ASSY, LIMIT (FOR PUMP MOTOR) -----	1
5702-44	SWITCH ASSY, LIMIT, (FOR PARKING BRAKE) -----	1
5702-AF	RELAY ASSY, BATTERY CAPACITY -----	1
5702-AG	BDDY, SWITCH -----	1
5702-AH	HOLDER, HORN POINT -----	1
5702-AI	SPRING, HORN CONTACT -----	1
5702-AJ	COVER -----	1
5702-AK	LOCKING BLOCK -----	1
5702-AL	COVER, RUBBER -----	1
5702-AM	HARNES ASSY -----	1
5702-AN	ACTUATOR -----	2
5702-AO	PLATE, SWITCH -----	1
5702-AP	LEVER SIGNAL -----	1
5702-AQ	BELLOWS -----	1
5702-AR	ROLLER -----	1
5702-AS	HOLDER, ROLLER -----	1
5702-AT	SPRING -----	1
5702-AU	BRACKET, PARKING BRAKE -----	1
5702-AX	HARNES ASSY -----	1
5702-AY	BRACKET, CHIME -----	1
5702-BB	COVER, LIMIT SWITCH, NO.1 -----	1
5702-BC	SEAL, COVER -----	1
5702-BD	COVER SUB-ASSY, LIMIT SWITCH, NO.2 -----	1
5702-BE	COVER, BRAKE SWITCH -----	1

FIG. 5706 SPEEDOMETER & SPEED ALARM

5706

(SPEEDOMETER)

(SPEEDOMETER)

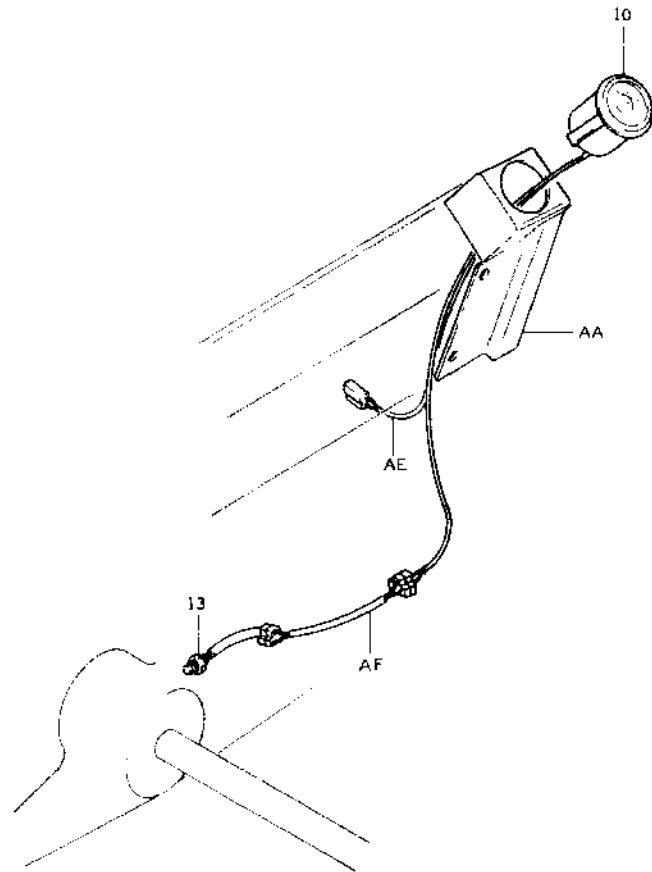

5706 005

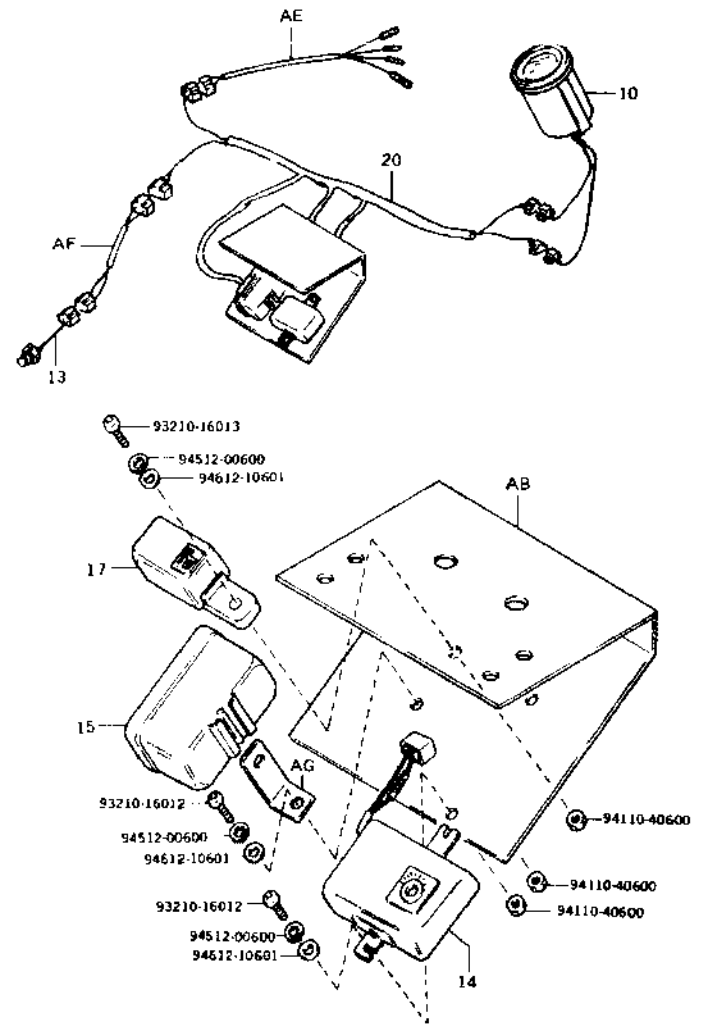

5706 006

5706

PART NAME CODE	PART NAME	QTY
5706-10	SPEEDOMETER ASSY -----	1
5706-13	PICK-UP ASSY, SPEEDOMETER -----	1
5706-14	BOX ASSY, SPEED ALARM -----	1
5706-15	RELAY ASSY -----	1
5706-17	BUZZER ASSY, SPEED ALARM -----	1
5706-20	HARNES SUB-ASSY, SPEED ALARM -----	1
5706-AA	BRACKET, SPEEDOMETER -----	1
5706-AB	BRACKET SUB-ASSY, SPEED ALARM -----	1
5706-AE	HARNES, SPEEDOMETER -----	1
5706-AF	HARNES, SPEEDOMETER PICK UP -----	1
5706-AG	STAY, RELAY -----	1

(MAIN) (42)

G210

FIG. 5801 WIPER MOTOR & BLADE

5801

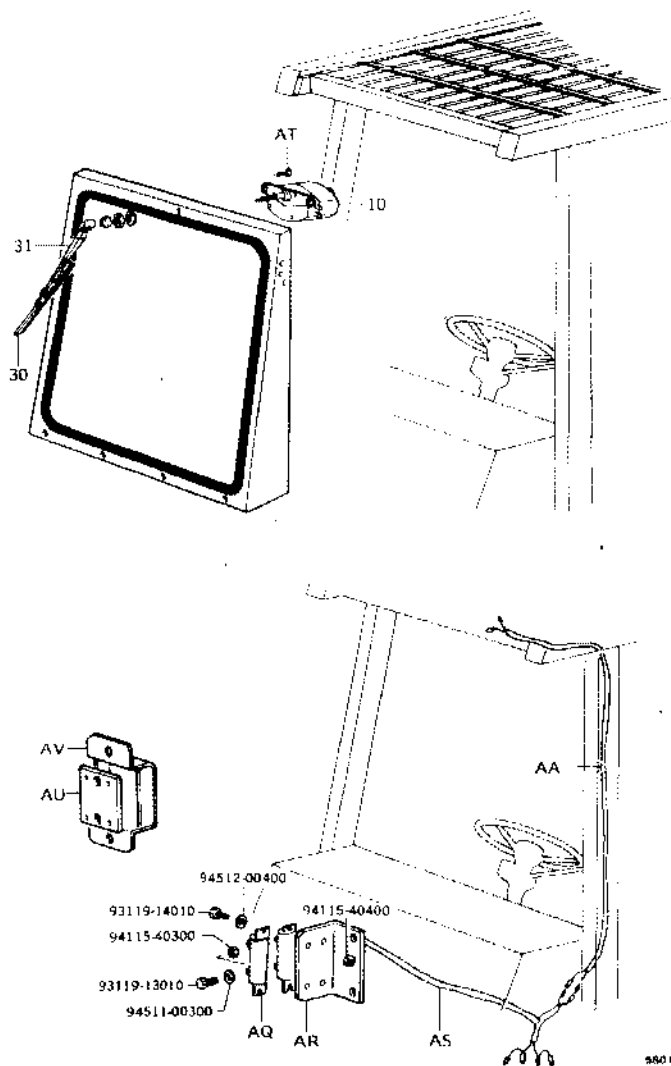

PART NAME CODE	PART NAME	QTY
5801-10	MOTOR ASSY, WIPER -----	1
5801-30	BLADE SUB-ASSY, WIPER -----	1
5801-31	ARM SUB-ASSY, WIPER -----	1
5801-AA	HARNES, WIPER -----	1
5801-AQ	RESISTER ASSY -----	2
5801-AS	HARNES ASSY, RESISTER -----	1
5801-AT	SCREW, W/WASHER -----	2
5801-AU	PLATE, RESISTER SET -----	1
5801-AV	COVER, RESISTER -----	1

FIG. 6101 MAST

6101

F

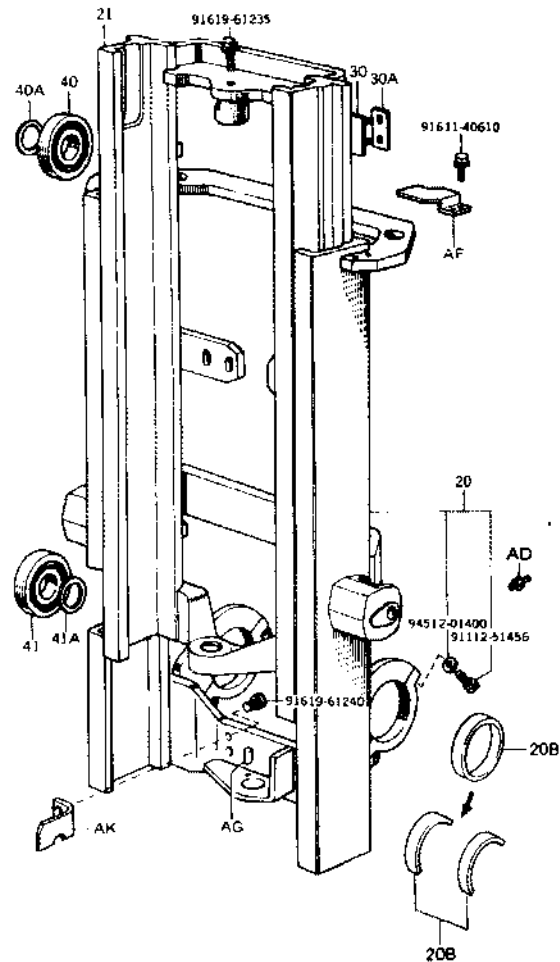

8109 064

PART NAME CODE	PART NAME	QTY
6101-20	MAST SUB-ASSY, OUTER -----	1
6101-20B	BUSH, MAST SUPPORT -----	1
6101-21	MAST SUB-ASSY, INNER -----	1
6101-30	STRIP SUB-ASSY, OUTER MAST -----	2
6101-30A	SHIM, OUTER MAST STRIP -----	99
6101-40	ROLLER, LIFT (FOR OUTER MAST) -----	2
6101-40A	SHIM, LIFT ROLLER (FOR OUTER MAST) -----	99
6101-41	ROLLER, LIFT (FOR INNER MAST) -----	2
6101-41A	SHIM, LIFT ROLLER (FOR INNER MAST) -----	99
6101-A0	FITTING, GREASE -----	2
6101-AF	COVER, ROLLER -----	2
6101-AG	PIN, SPRING -----	1
6101-AK	STOPPER, REAR CYLINDER -----	1

(7) (1)

8218

FIG. 6301 LIFT BRACKET & FORK

6301

F

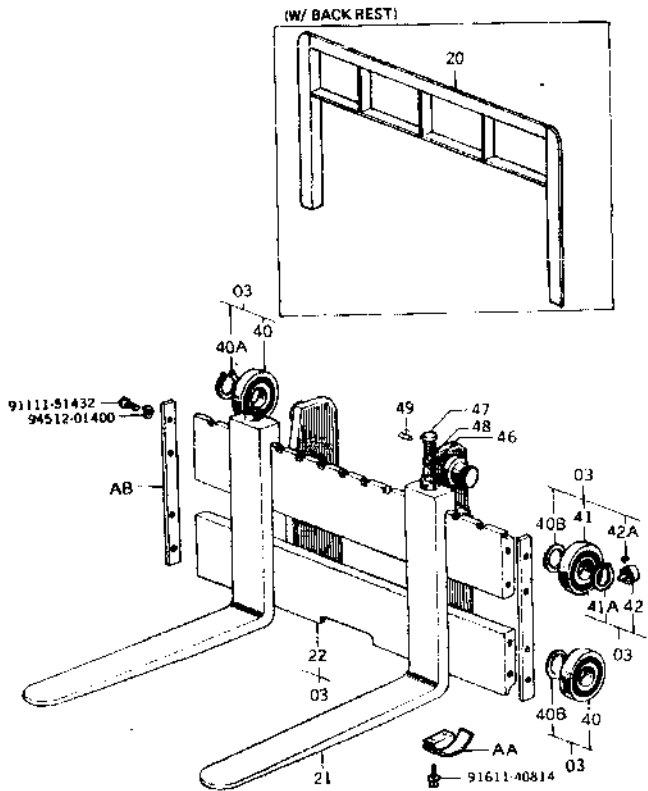

6301-041

PART NAME CODE	PART NAME	QTY
6301-03	BRACKET ASSY, LIFT -----	1
6301-20	BACKREST SUB-ASSY -----	1
6301-21	FORK SUB-ASSY -----	2
6301-22	BRACKET SUB-ASSY, LIFT -----	1
6301-40	ROLLER, LIFT (UPPER, LOWER) -----	4
6301-40A	RING, SHAFT SNAP (UPPER, LOWER) -----	2
6301-40B	SHIM, LIFT ROLLER -----	99
6301-41	ROLLER, LIFT (CENTER) -----	2
6301-41A	RING, SHAFT SNAP (CENTER) -----	2
6301-42	ROLLER, SIDE -----	2
6301-42A	SHIM (FOR SIDE ROLLER) -----	99
6301-46	PIN, FORK STOPPER -----	2
6301-47	KNOB, FORK STOPPER PIN -----	2
6301-48	SPRING, FORK STOPPER PIN -----	2
6301-49	PIN, SPRING (FOR FORK STOPPER PIN) -----	2
6301-AA	COVER, LIFT BRACKET ROLLER -----	4
6301-AB	PLATE, SIDE -----	2

FIG. 6302 CHAIN & CHAIN WHEEL

6302

F

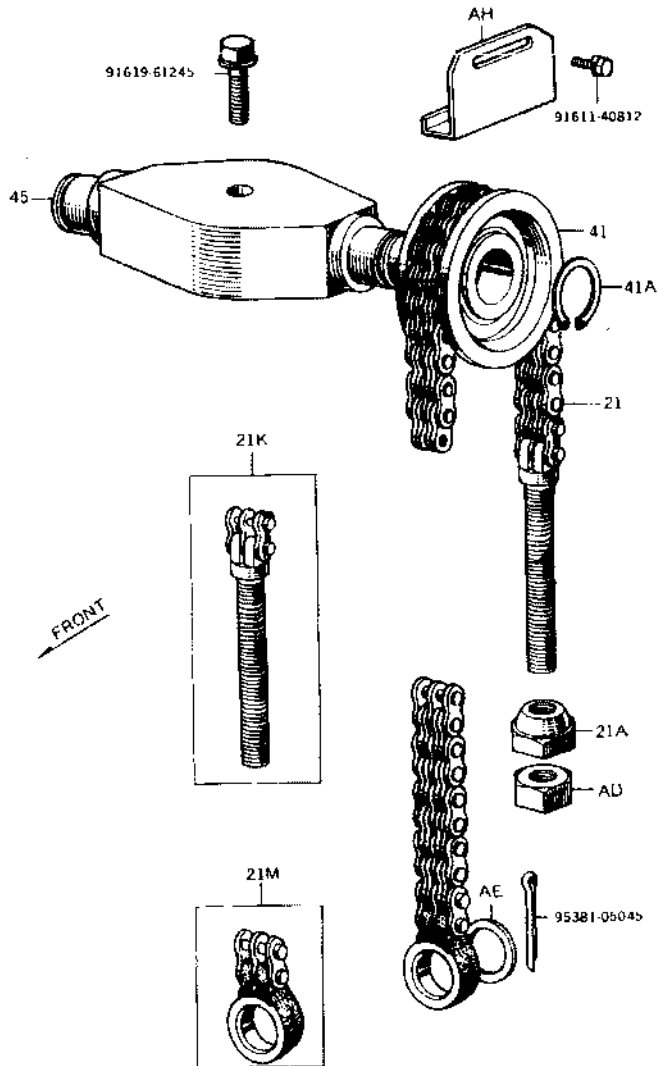

PART NAME CODE	PART NAME	QTY
6302-21	CHAIN SUB-ASSY (FRONT) -----	2
6302-21A	NUT, CHAIN ADJUST (FRONT) -----	2
6302-21K	BOLT KIT, CHAIN ANCHOR, NO.1 (FRONT) -----	2
6302-21M	BOLT KIT, CHAIN EYE (FRONT) -----	2
6302-41	WHEEL, CHAIN (FRONT) -----	2
6302-41A	RING, SHAFT SNAP (FOR FRONT CHAIN WHEEL) ---	2
6302-45	SUPPORT, CHAIN WHEEL -----	1
6302-A0	NUT, HEXAGON -----	2
6302-AE	WASHER, CHAIN SPECIAL -----	2
6302-AH	COVER, CHAIN WHEEL -----	2

6302-025

(F) (3)

G210

FIG. 6505 FRONT LIFT CYLINEER

6505

F

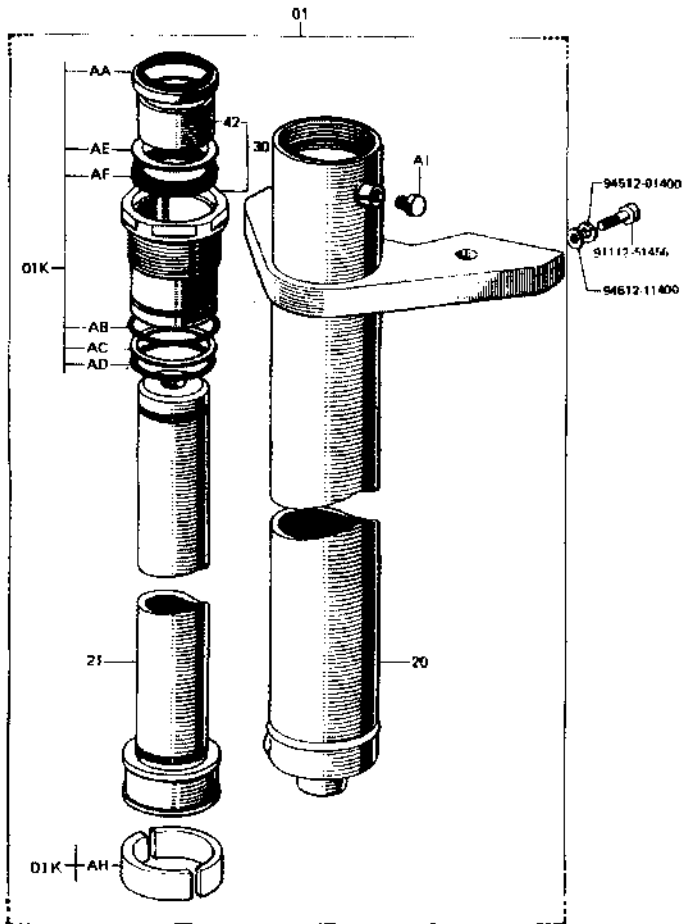

6505-007A

PART NAME CODE	PART NAME	QTY
6505-01	CYLINDER ASSY, LIFT -----	1
6505-01K	CYLINDER O/R KIT, LIFT -----	1
6505-20	CYLINDER SUB-ASSY, LIFT -----	1
6505-21	ROD SUB-ASSY, LIFT CYLINDER -----	1
6505-30	GUIDE SUB-ASSY, LIFT CYLINDER ROD -----	1
6505-42	SLEEVE, LIFT CYLINDER ROD GUIDE -----	1
6505-AA	SEAL, DUST -----	1
6505-AB	RING, O -----	1
6505-AC	RING, BACK UP -----	1
6505-AD	RING, O -----	1
6505-AE	RING, BACK UP -----	1
6505-AF	PACKING, U -----	1
6505-AH	BUSHING -----	1
6505-AI	PLUG -----	1

FIG. 6506 REAR LIFT CYLINDER

6506

F

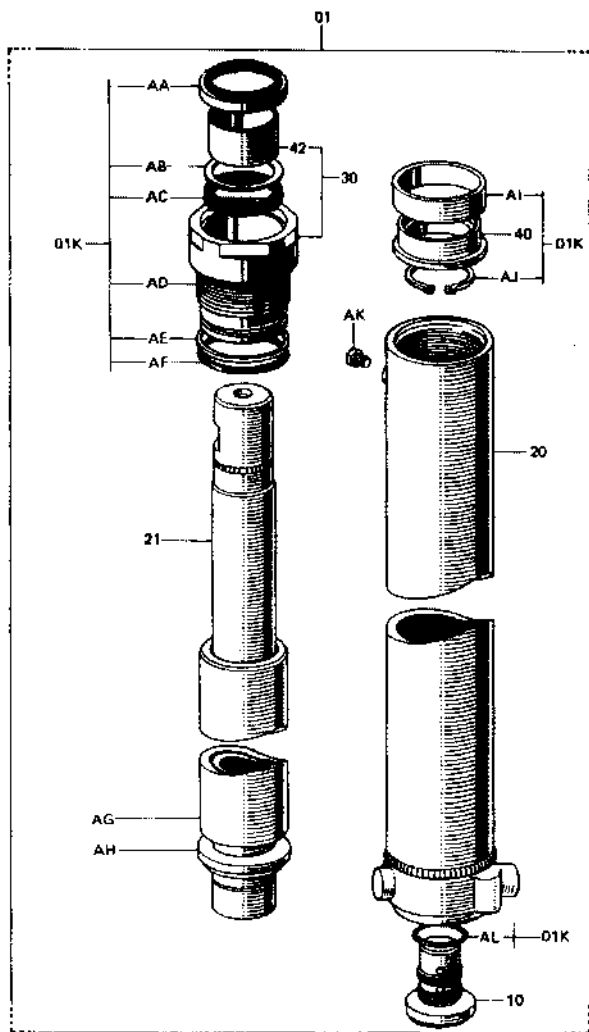

6506-001

PART NAME CODE	PART NAME	QTY
6506-01	CYLINDER ASSY, LIFT	1
6506-01K	CYLINDER O/H KIT, LIFT	1
6506-10	VALVE ASSY, FLOW REGULATOR	1
6506-20	CYLINDER SUB-ASSY, LIFT	1
6506-21	ROD SUB-ASSY, LIFT CYLINDER	1
6506-30	GUIDE SUB-ASSY, CYLINDER ROD	1
6506-40	PISTON, LIFT CYLINDER	1
6506-42	SLEEVE, LIFT CYLINDER ROD GUIDE	1
6506-AA	SEAL, DUST	1
6506-AB	RING, BACK UP	1
6506-AC	PACKING, U	1
6506-AD	RING, O	1
6506-AE	RING, BACK UP	1
6506-AF	RING, O	1
6506-AG	SPACER, LIFT CYLINDER	1
6506-AH	RING, SPACER	1
6506-AI	RING, WEAR	1
6506-AJ	RING, SHAFT SNAP	1
6506-AK	PLUG	1
6506-AL	RING, O	1

(F) (5)

G210

FIG. 6511 TILT CYLINDER

6511

F

F

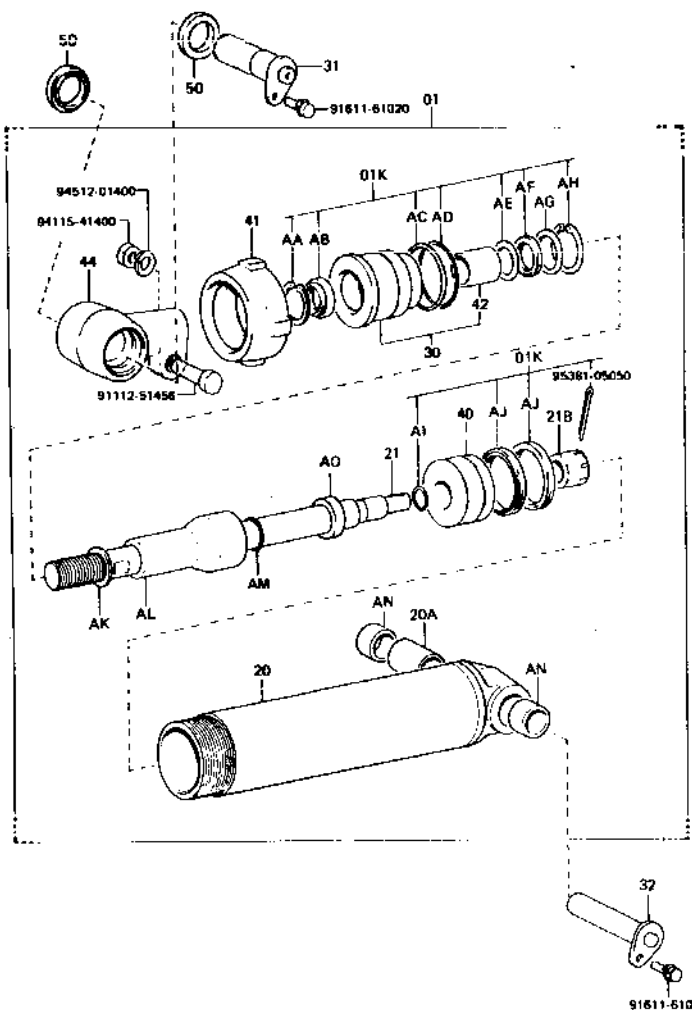

91611-61020

6511 010

テイルト角度表
TABLE OF TILT RANGE

生産期間 PROD DATE	型式 MODELS	タイヤ TIRE	揚 高 LIFTING HEIGHT	備 考 DESCRIPTION	テイルト角 TILT RANGE
8009-	F, FV, M, SV, V	SINGLE	H2000-H4000		6D - 12D
8009-	F, FV, M, SV, V	DOUBLE	H2000-H4500		6D - 12D
8009-	F, FV, M, SV, V	SINGLE	H4500-H8000		6D - 6D
8009-	F, FV, M, SV, V	DOUBLE	H5000		6D - 6D
8009-	F, FV, M, SV, V		H2000	FRONT GLASS	6D - 10D
8009-	FSV, FS		H3700-H8500		6D - 6D
8008-	F, FV, M, SV, V	SINGLE	H2000-H4000	AUSTRALIA	3D - 12D
8009-	F, FV, M, SV, V	DOUBLE	H2000-H4500	AUSTRALIA	3D - 12D
8009-	F, FV, M, SV, V	SINGLE	H4500-H5000	AUSTRALIA	3D - 6D
8009-	F, FV, M, SV, V	DOUBLE	H5000	AUSTRALIA	3D - 6D
8009-	F, FV, M, SV, V		H2000	FRONT GLASS AUSTRALIA	3D 10D
8009-	FV, M, SV, V		H3700-H8500	AUSTRALIA	3D - 6D

6511-019

FIG. 6511 TILT CYLINDER

6511

F

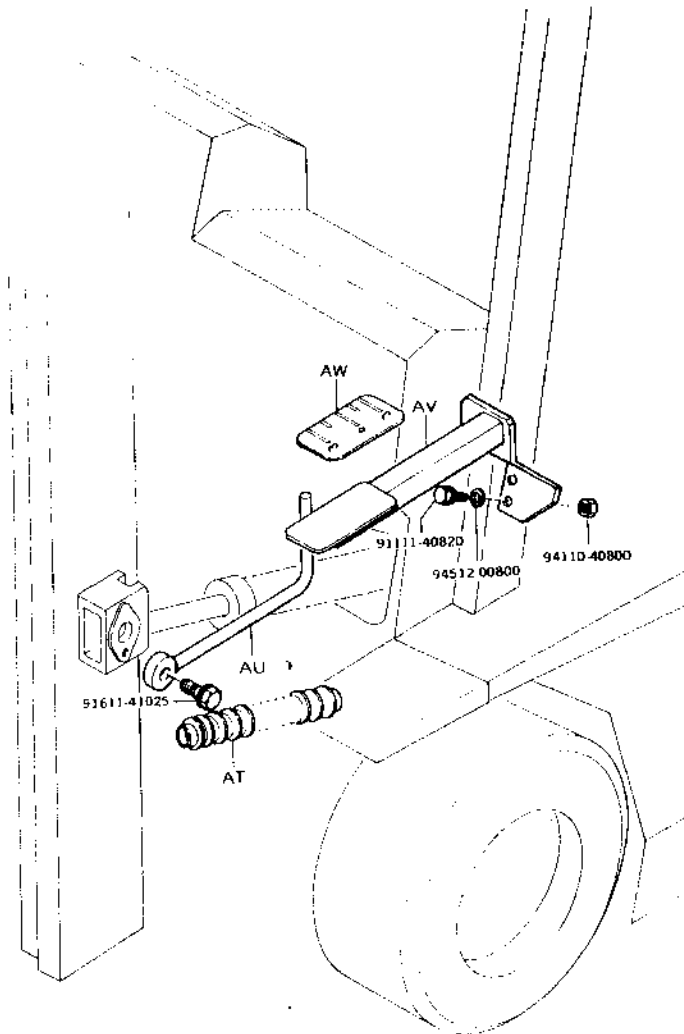

PART NAME CODE	PART NAME	QTY
6511-01	CYLINDER ASSY, TILT	2
6511-01K	CYLINDER O/H KIT, TILT	2
6511-20	CYLINDER SUB-ASSY, TILT	2
6511-20A	BUSH, PIN (FOR CYLINDER)	2
6511-21	ROD SUB-ASSY, TILT CYLINDER PISTON	2
6511-21B	NUT, CASTLE	2
6511-30	GUIDE SUB-ASSY, TILT CYLINDER ROD	2
6511-31	PIN SUB-ASSY, TILT CYLINDER	2
6511-32	PIN SUB-ASSY, TILT CYLINDER, RR	2
6511-40	PISTON, TILT CYLINDER	2
6511-41	COVER, TILT CYLINDER	2
6511-42	SLEEVE, TILT CYLINDER ROD GUIDE	2
6511-44	JOINT, PISTON ROD	2
6511-50	SEAL, GREASE	2
6511-AA	RING, HOLE SNAP	2
6511-AB	SEAL, DUST	2
6511-AC	RING, BACK UP	2
6511-AD	RING, O	2
6511-AE	RING, BACK UP	2
6511-AF	PACKING, U	2
6511-AG	PLATE, STOPPER	2
6511-AH	RING, HOLE SNAP	2
6511-AI	RING, O	2
6511-AJ	PACKING, U	4
6511-AK	SHIM, TILT CONTROL	99
6511-AL	SPACER, TILT CONTROL	2
6511-AM	RING, O	4
6511-AN	COLLAR	4
6511-AP	SPACER, TILT CONTROL	2
6511-AT	BOOT SUB-ASSY	2
6511-AU	BAR SUB-ASSY, TILT GAUGE	1
6511-AV	BRACKET SUB-ASSY, TILT GAUGE	1
6511-AW	PLATE, TILT CYLINDER INDICATOR	1

FIG. 6701 OIL PUMP

6701

F

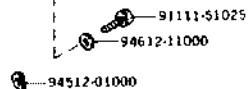
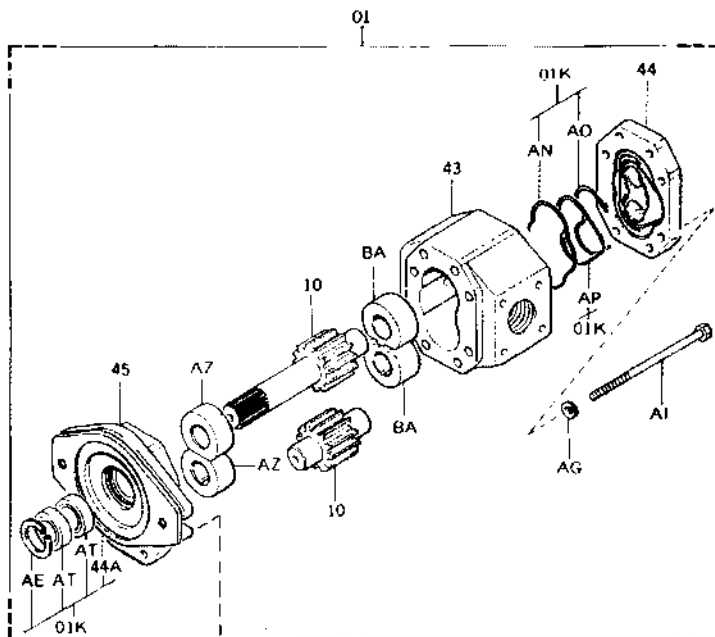

4701-010

PART NAME CODE	PART NAME	QTY
6701-01	PUMP ASSY, OIL -----	1
6701-01K	PUMP O/H KIT, OIL -----	1
6701-10	GEAR SET -----	1
6701-11	BUSH SET, NO.1 -----	2
6701-43	BODY -----	1
6701-44	FLANGE, MOUNTING -----	1
6701-45	COVER -----	1
6701-AA	SEAL, BUSHING -----	2
6701-AB	RING, BACKING, RH -----	2
6701-AC	RING, BACKING, LH -----	2
6701-AD	SEAL, OIL -----	1
6701-AE	RING, SNAP -----	1
6701-AF	BOLT -----	4
6701-AG	WASHER, SPRING -----	4
6701-AH	SEAL, BODY -----	2
6701-AI	BOLT -----	2

(F) (7)

G210

FIG. 6705 OIL CONTROL VALVE

6705

F (3-WAY..UL-EE)

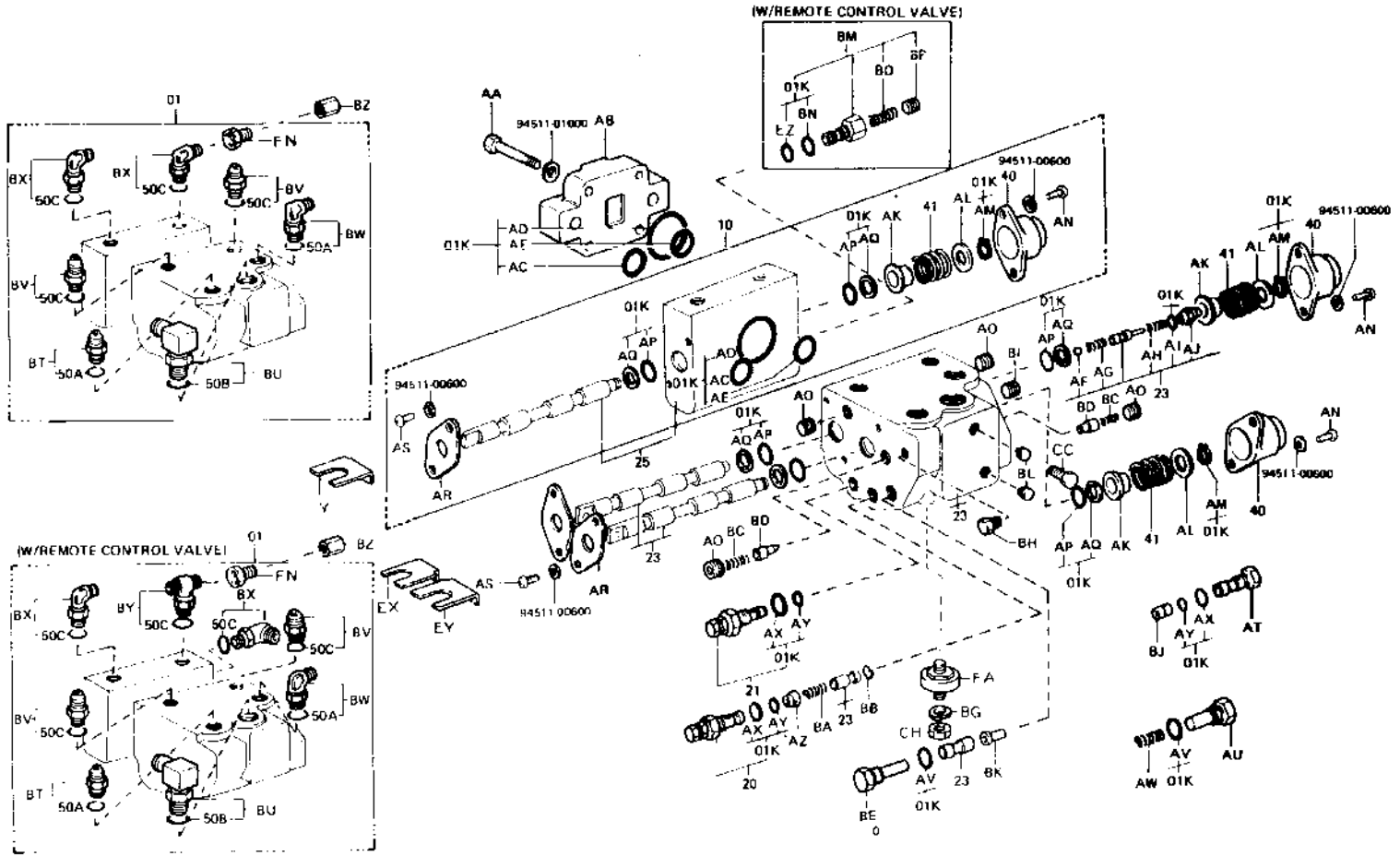

FIG. 6705 OIL CONTROL VALVE

6705

F (3-WAY)

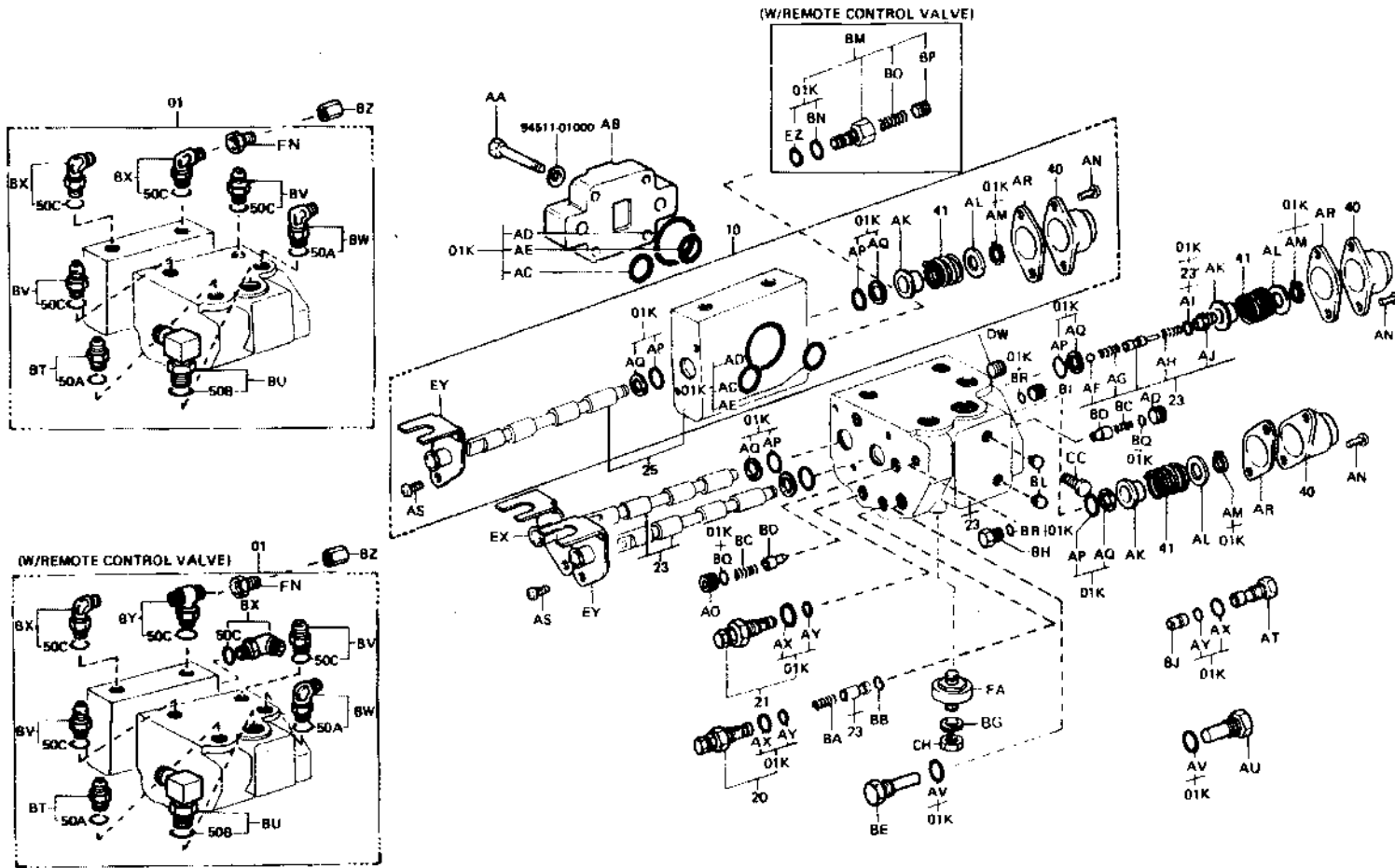

FIG. 6705 OIL CONTROL VALVE

6705

F (4-WAY)

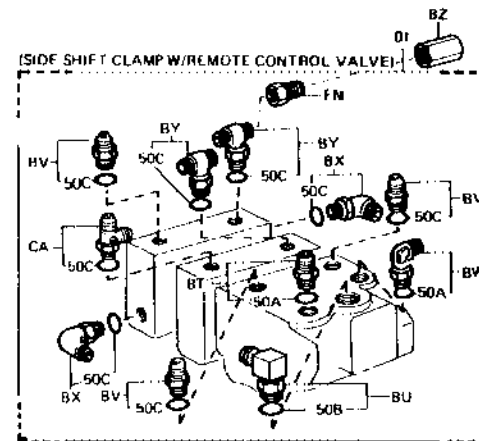
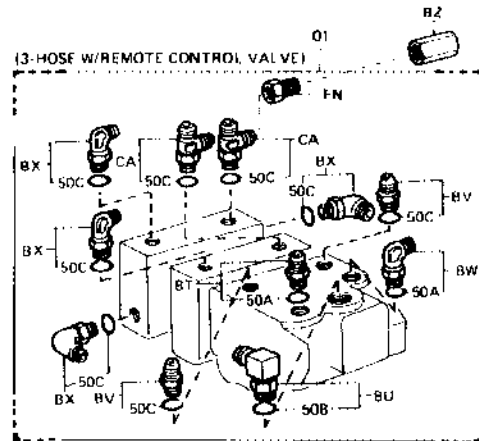
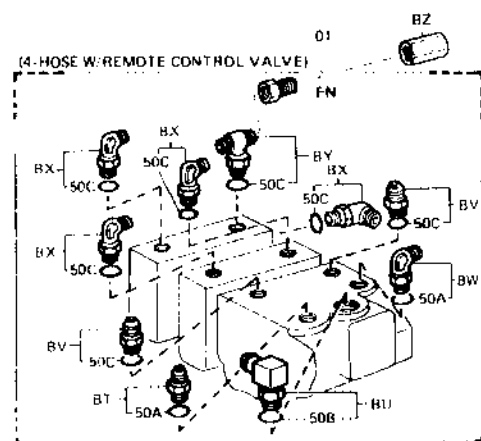
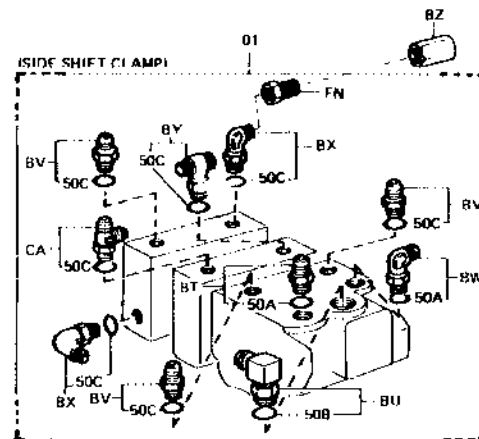
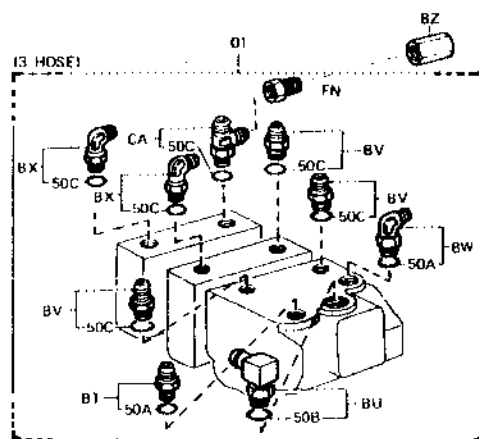
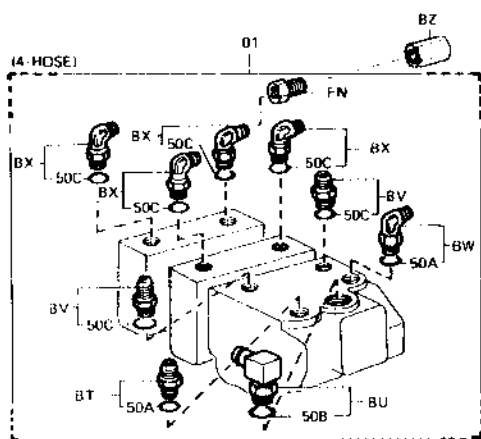

FIG. 6705 OIL CONTROL VALVE

6705

F (4-WAY, UL-EE)

(W/REMOTE CONTROL VALVE)

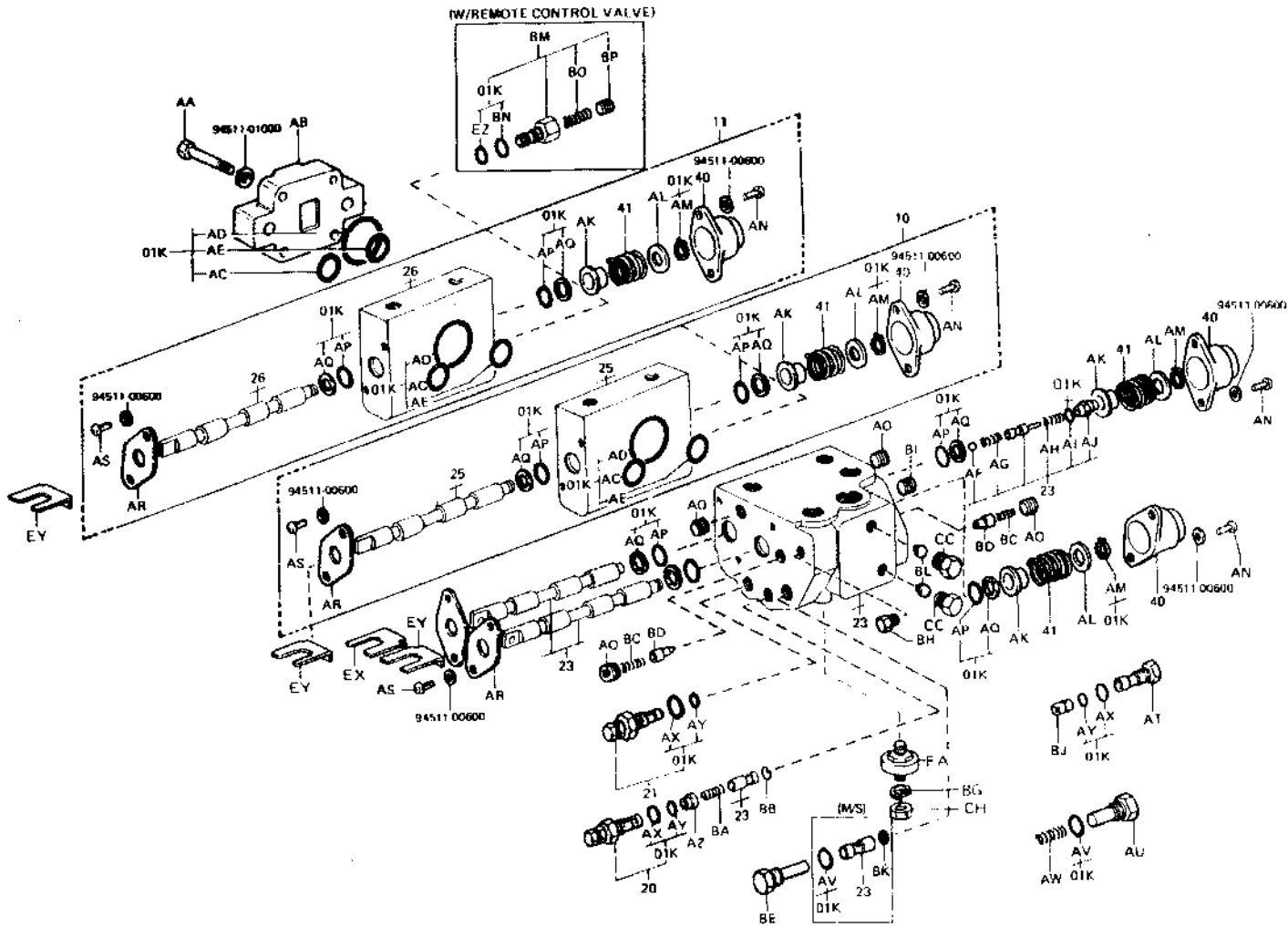
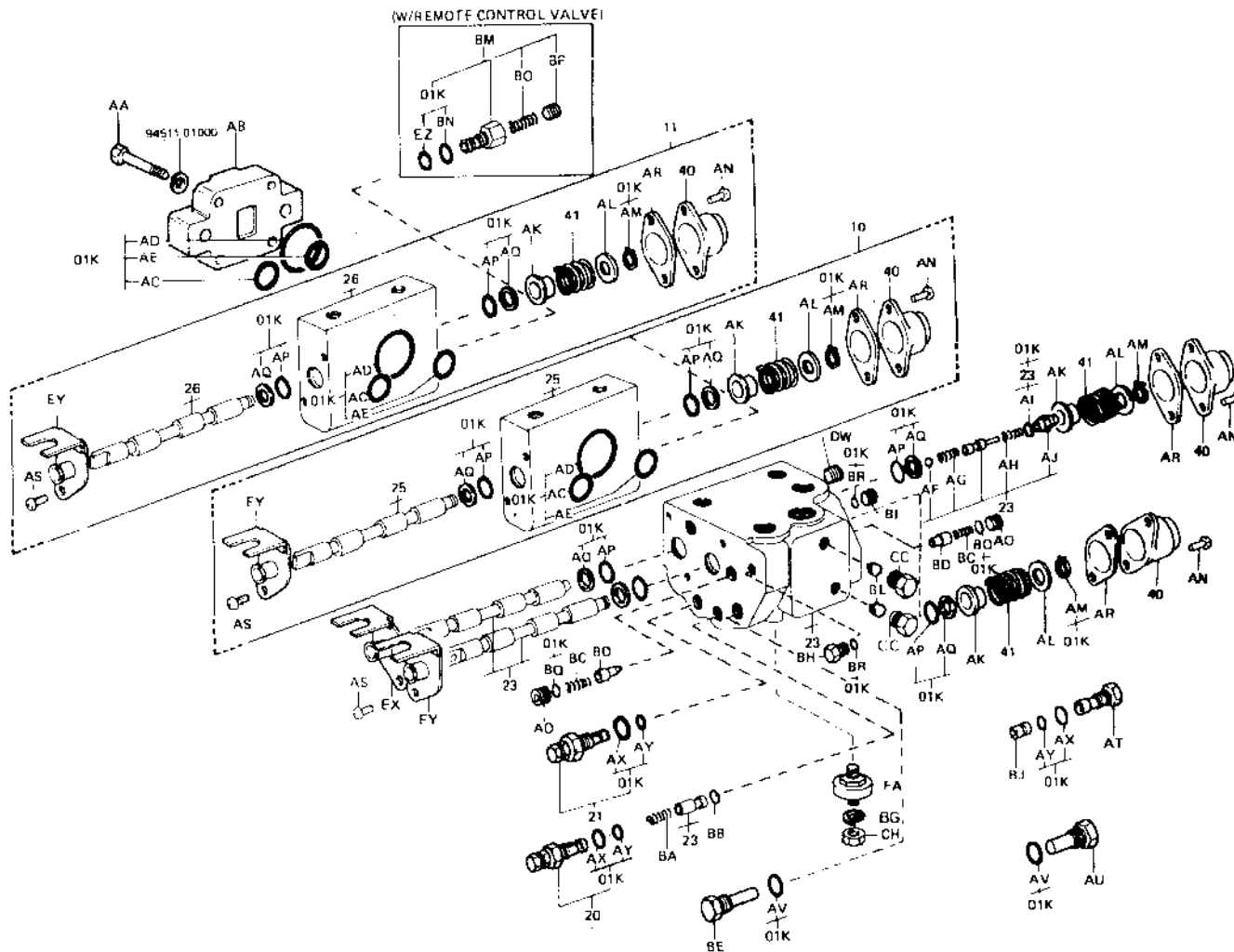

FIG. 6705 OIL CONTROL VALVE

6705

F (4-WAY)



6705

PART NAME CODE	PART NAME	QTY
6705-01	VALVE ASSY, OIL CONTROL	1
6705-01K	VALVE U/H KIT, OIL CONTROL	1
6705-10	VALVE ASSY, PLUNGER SECTION, NO.1	1
6705-11	VALVE ASSY, PLUNGER SECTION, NO.2	1
6705-20	VALVE SET, PILOT RELIEF, NO.1	1
6705-21	VALVE SET, PILOT RELIEF, NO.2	1
6705-23	HOUSING & SPOOL SET, NO.1	1
6705-25	HOUSING & SPOOL SET, ATTACHMENT, NO.1	1
6705-26	HOUSING & SPOOL SET, ATTACHMENT, NO.2	1
6705-40	COVER, SPRING	2
6705-41	SPRING, COMPRESSION (FOR SPOOL RETURN)	2
6705-50A	RING, O, NO.1 (FOR VALVE FITTING)	2
6705-50B	RING, O, NO.2 (FOR VALVE FITTING)	1
6705-50C	RING, O, NO.3 (FOR VALVE FITTING)	2
6705-AA	BOLT	4
6705-AB	HOUSING, OUTLET	1
6705-AC	RING, O	1
6705-AD	RING, O	1
6705-AE	RING, O	1
6705-AF	BALL, STEEL	1
6705-AG	SPRING	1
6705-AH	SPRING, COMPRESSION	1
6705-AI	RING, O	1
6705-AJ	STOPPER	1
6705-AK	HOLDER, SPRING	2
6705-AL	WASHER, PLATE	2
6705-AM	RING, SHAFT SNAP	2
6705-AN	SCREW	4
6705-AD	PLUG	2
6705-AP	RING, O	4
6705-AQ	RING, BACK UP	4
6705-AR	HOLDER, SEAL	2
6705-AS	SCREW	4
6705-AT	STOPPER	1
6705-AU	STOPPER	1
6705-AV	RING, O	2
6705-AX	RING, O	3
6705-AY	RING, O	3
6705-BA	SPRING, COMPRESSION	1
6705-BB	WIRE, ORIFICE TURNING	1
6705-BC	SPRING, COMPRESSION	2
6705-BO	PLUNGER, CHECK	2
6705-BE	STOPPER	1
6705-BG	WASHER	4
6705-BH	PLUG	1
6705-BI	PLUG	1
6705-BJ	SEAT, VALVE	1
6705-BL	SEAT, INSERT	2
6705-BM	VALVE SUB-ASSY, RELIEF	1
6705-BN	RING, O	1
6705-BO	SPRING	1
6705-BP	STOPPER	1
6705-BQ	RING, O	2

(F) (B) G210

PART NAME CODE	PART NAME	QTY
6705-BR	RING, O	2
6705-BT	FITTING	1
6705-BU	FITTING	1
6705-BV	FITTING	2
6705-BW	FITTING	1
6705-BX	FITTING	2
6705-BY	FITTING	1
6705-BZ	PLUG	2
6705-CA	FITTING	1
6705-CC	PLUG	2
6705-CH	NUT	4
6705-DW	PLUG	1
6705-EX	BRACKET SUB-ASSY, TILT	1
6705-EY	BRACKET SUB-ASSY, LIFT	1
6705-EZ	RING, O	1
6705-FA	INSULATOR	4
6705-FN	FITTING	2

(F) (9) G210

FIG. 7609 DIL CONTROL VALVE LINK

6709

F

F (3-WAY)

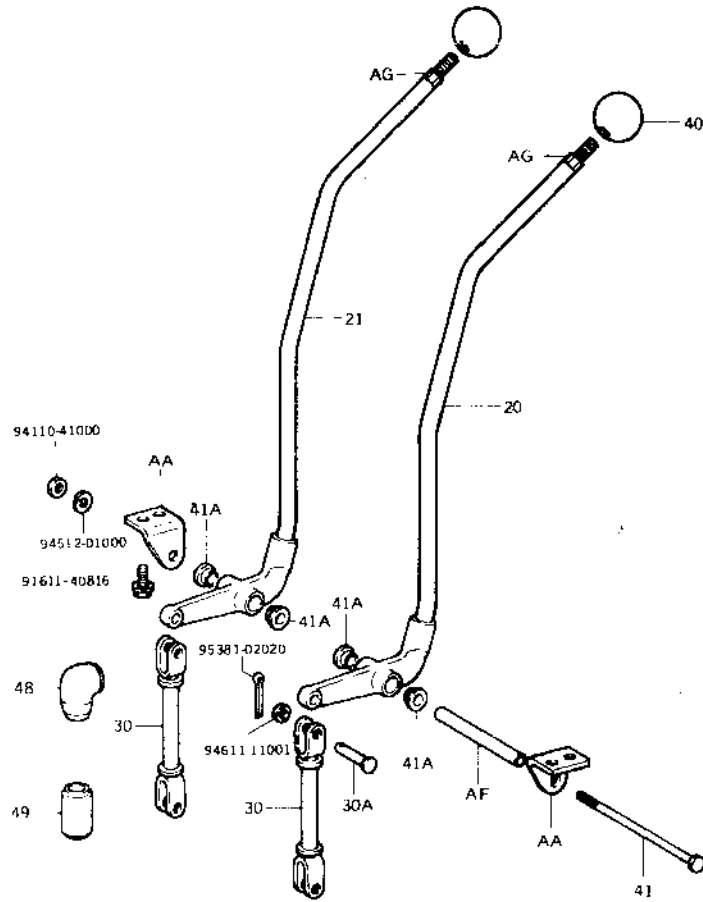

6709-016

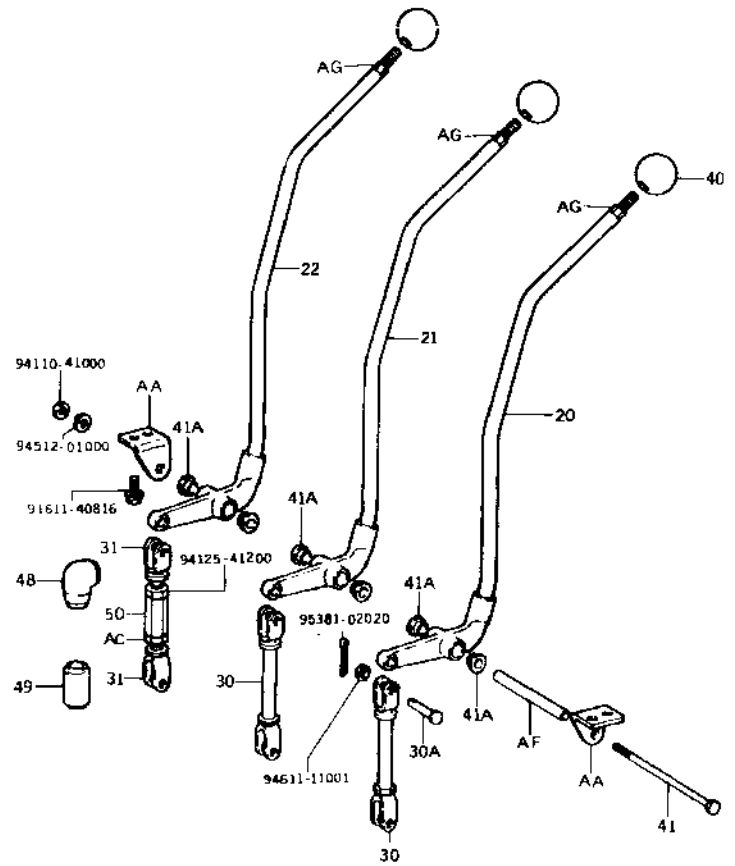

6709-017

FIG. 7609 OIL CONTROL VALVE LINK

6709

F (4-WAY)

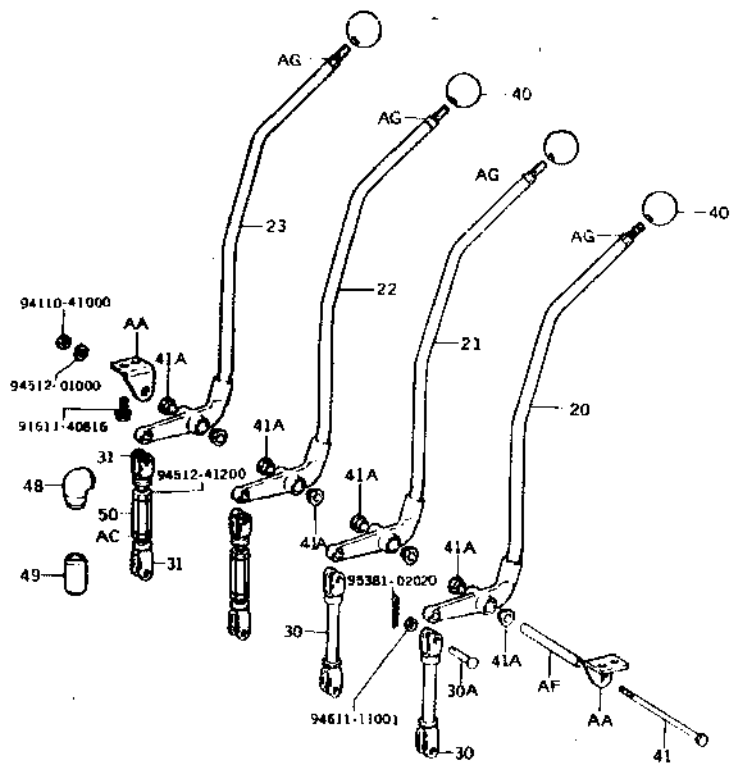

6709 019

PART NAME CODE	PART NAME	QTY
6709-20	LEVER SUB-ASSY, CONTROL VALVE, NO.1	1
6709-21	LEVER SUB-ASSY, CONTROL VALVE, NO.2	1
6709-22	LEVER SUB-ASSY, CONTROL VALVE, NO.3	1
6709-23	LEVER SUB-ASSY, CONTROL VALVE, NO.4	1
6709-30	ROD SUB-ASSY, CONTROL VALVE LEVER, NO.1	2
6709-30A	PIN (FOR CONTROL VALVE LEVER ROD)	4
6709-31	ROD SUB-ASSY, CONTROL VALVE LEVER, NO.2	1
6709-40	KNOB, OIL CONTROL VALVE LEVER	2
6709-41	PIN, OIL CONTROL VALVE LEVER	1
6709-41A	BUSH (FOR LEVER PIN)	4
6709-48	BOOT, CONTROL VALVE LINK, NO.1	2
6709-49	BOOT, CONTROL VALVE LINK, NO.2	2
6709-50	TURNBUCKLE	1
6709-AA	BRACKET SUB-ASSY	1
6709-AC	NUT	1
6709-AF	SPACER	1
6709-AG	BOLT, STUD	2

(F) (10) G210

FIG. 6801 BODY PIPING

6801

F

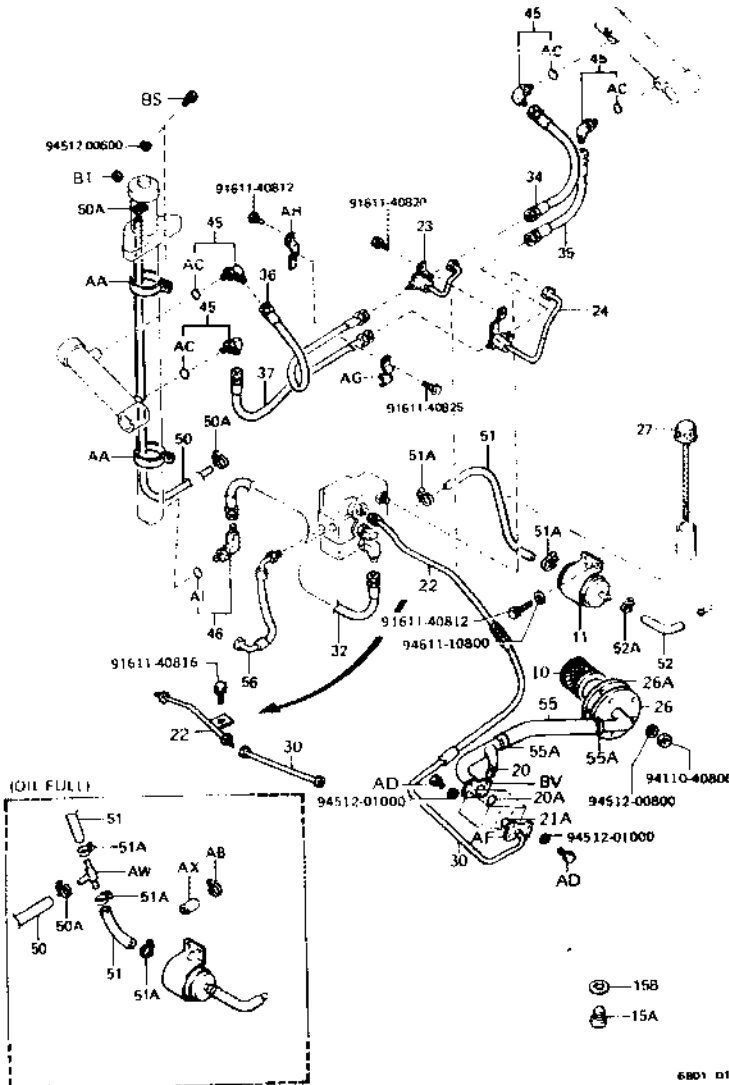

PART NAME CODE	PART NAME	QTY
6801-10	FILTER ASSY, SUCTION	1
6801-11	FILTER ASSY, RETURN	1
6801-15A	PLUG (FOR OIL TANK DRAIN)	1
6801-15B	GASKET (FOR OIL TANK DRAIN PLUG)	1
6801-20	PIPE SUB-ASSY (PUMP INLET)	1
6801-20A	RING, O (FOR OIL PUMP INLET)	1
6801-21A	RING, O (FOR OIL PUMP OUTLET)	1
6801-22	PIPE SUB-ASSY (PUMP TO VALVE)	1
6801-23	PIPE SUB-ASSY (TILT CYLINDER FRONT)	1
6801-24	PIPE SUB-ASSY (TILT CYLINDER REAR)	1
6801-26	OUTLET SUB-ASSY, OIL TANK	1
6801-26A	PACKING, OIL TANK COVER	1
6801-27	CAP SUB-ASSY, OIL TANK	1
6801-30	HOSE, HIGH PRESSURE, NO.1 (PUMP TO VALVE)	1
6801-32	HOSE, HIGH PRESSURE, NO.1 (VALVE TO LIFT)	1
6801-34	HOSE, HIGH PRESSURE, NO.1 (TILT FRONT)	1
6801-35	HOSE, HIGH PRESSURE, NO.1 (TILT REAR)	1
6801-36	HOSE, HIGH PRESSURE, NO.2 (TILT FRONT)	1
6801-37	HOSE, HIGH PRESSURE, NO.2 (TILT REAR)	1
6801-45	FITTING (FOR TILT CYLINDER)	2
6801-46	FITTING (FOR LIFT CYLINDER)	1
6801-51A	CLAMP (FOR VALVE TO TANK NO.1 HOSE)	2
6801-52	HOSE, LOW PRESSURE, NO.2 (VALVE TO TANK)	1
6801-52A	CLAMP (FOR VALVE TO TANK NO.2 HOSE)	2
6801-55	HOSE, LOW PRESSURE (TANK TO PUMP)	1
6801-55A	CLAMP (FOR TANK TO PUMP HOSE)	2
6801-56	HOSE, LOW PRESSURE (STEERING TO VALVE)	1
6801-AB	CLAMP	1
6801-AC	RING, O	4
6801-AD	BOLT	8
6801-AF	FLANGE, SPLIT	1
6801-AG	CLAMP	1
6801-AH	BRACKET SUB-ASSY, TILT HOSE	1
6801-AI	RING, O	1
6801-AX	CAP, OIL TANK OVERFLOW PIPE	1
6801-BS	BOLT	1
6801-BT	WASHER	1
6801-BV	FLANGE	2

FIG. 6802 MAST PIPING

6802

F

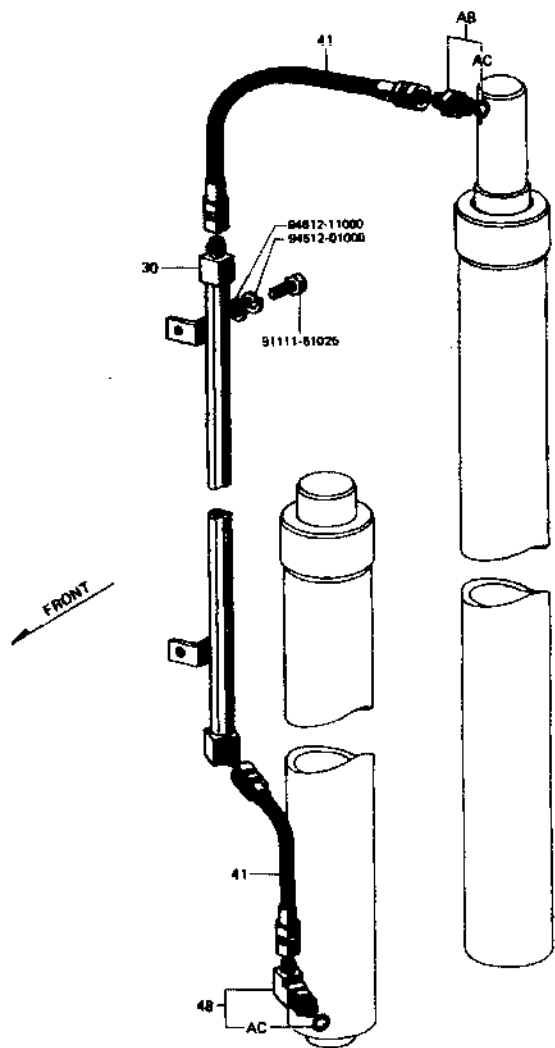

6802 001

PART NAME CODE	PART NAME	QTY
6802-30	PIPE SUB-ASSY, NO.1 (FRONT LIFT) -----	1
6802-41	HOSE, HIGH PRESSURE, NO.1 (FRONT LIFT) -----	2
6802-48	FITTING (FOR FRONT LIFT CYLINDER) -----	1
6802-AB	FITTING -----	1
6802-AC	RING, Ø -----	2

(F) (12)

G210

FIG. 6101 MAST

6101

FS

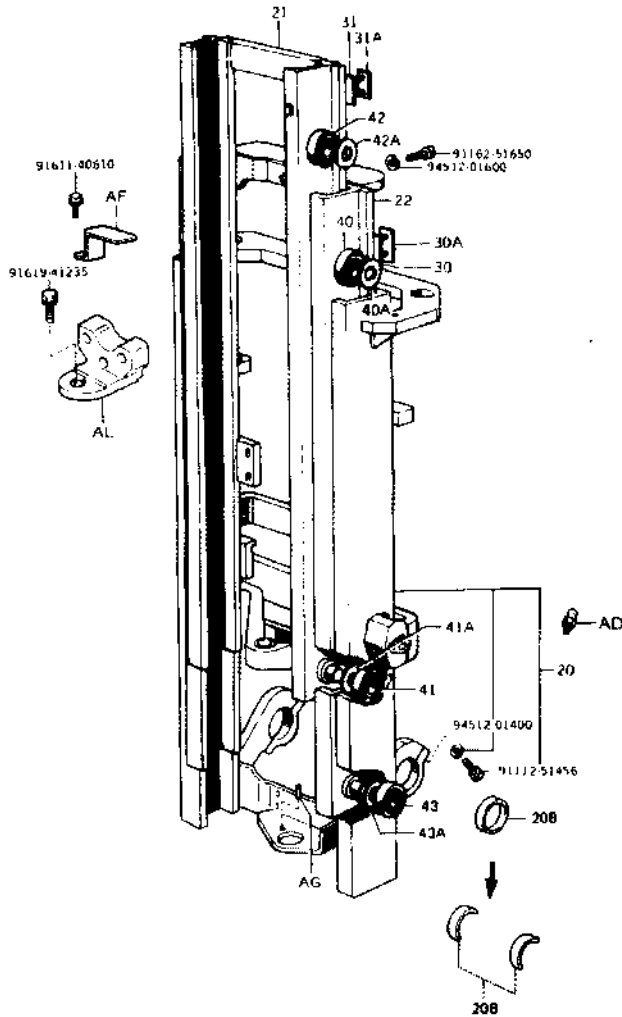

8101-076

PART NAME CODE	PART NAME	QTY
6101-20	MAST SUB-ASSY, OUTER	1
6101-200	CUSH, MAST SUPPORT	1
6101-21	MAST SUB-ASSY, INNER	1
6101-22	MAST SUB-ASSY, MIDDLE	1
6101-30	STRIP SUB-ASSY, OUTER MAST	2
6101-30A	SHIM, OUTER MAST STRIP	99
6101-31	STRIP SUB-ASSY, MIDDLE MAST	2
6101-31A	SHIM, MIDDLE MAST STRIP	99
6101-40	ROLLER, LIFT (FOR OUTER MAST)	2
6101-40A	SHIM, LIFT ROLLER (FOR OUTER MAST)	99
6101-41	ROLLER, LIFT (FOR INNER MAST)	2
6101-41A	SHIM, LIFT ROLLER (FOR INNER MAST)	99
6101-42	ROLLER, LIFT (FOR MIDDLE MAST UPPER)	2
6101-42A	SHIM, LIFT ROLLER (FOR MIDDLE MAST UPPER)	99
6101-43	ROLLER, LIFT (FOR MIDDLE MAST LOWER)	2
6101-43A	SHIM, LIFT ROLLER (FOR MIDDLE MAST LOWER)	99
6101-AD	FITTING, GREASE	2
6101-AF	COVER, ROLLER	2
6101-AG	PIN, SPRING	1
6101-AL	TOP, LIFT CYLINDER	1

(FS) (1)

G210

FIG. 6301 LIFT BRACKET & FORK

6301

FS

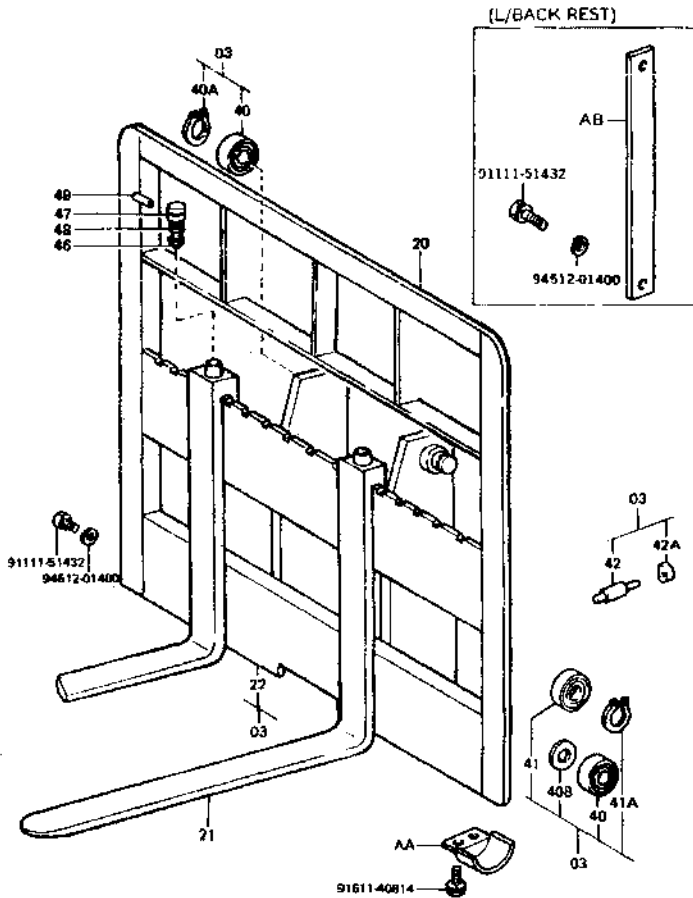

6301-002A

PART NAME CODE	PART NAME	QTY
6301-03	BRACKET ASSY, LIFT -----	1
6301-20	BACKREST SUB-ASSY -----	1
6301-21	FORK SUB-ASSY -----	2
6301-22	BRACKET SUB-ASSY, LIFT -----	1
6301-40	ROLLER, LIFT (UPPER, LOWER) -----	4
6301-40A	RING, SHAFT SNAP (UPPER, LOWER) -----	2
6301-40B	SHIM, LIFT ROLLER -----	99
6301-41	ROLLER, LIFT (CENTER) -----	2
6301-41A	RING, SHAFT SNAP (CENTER) -----	2
6301-42	ROLLER, SIDE -----	2
6301-42A	SHIM (FOR SIDE ROLLER) -----	99
6301-46	PIN, FORK STOPPER -----	2
6301-47	KNOB, FORK STOPPER PIN -----	2
6301-48	SPRING, FORK STOPPER PIN -----	2
6301-49	PIN, SPRING (FOR FORK STOPPER PIN) -----	2
6301-AA	COVER, LIFT BRACKET ROLLER -----	4
6301-AB	PLATE, SIDE -----	2

(FS) (2) G210

FIG. 6302 CHAIN & CHAIN WHEEL

6302

FS

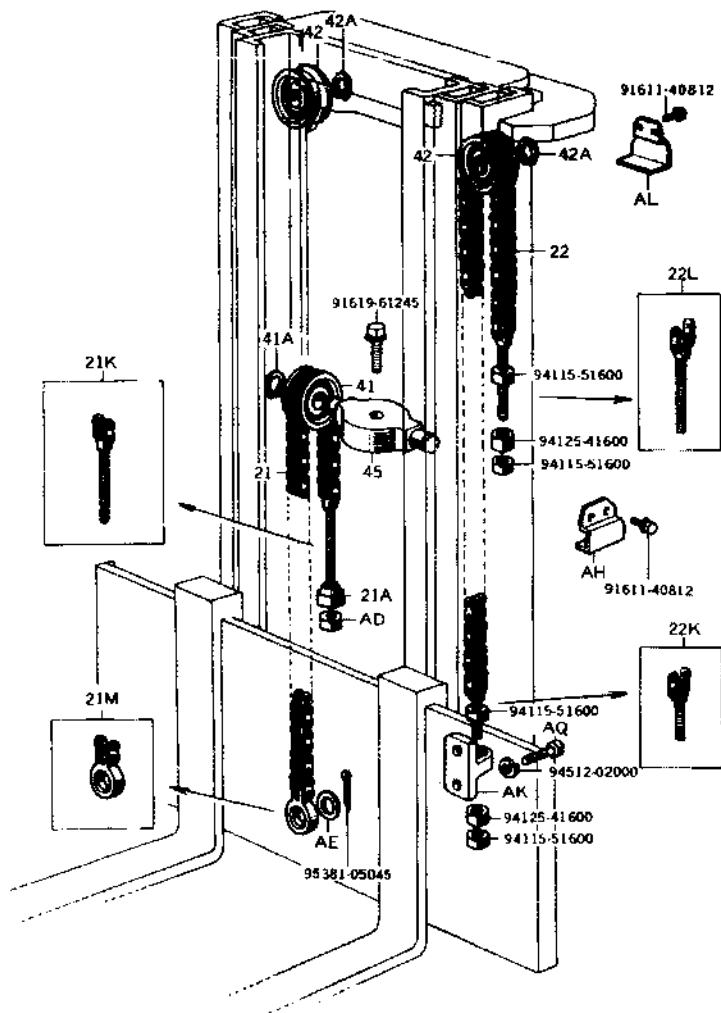

PART NAME CODE	PART NAME	QTY
6302-21	CHAIN SUB-ASSY (FRONT) -----	2
6302-21A	NUT, CHAIN ADJUST (FRONT) -----	2
6302-21K	BOLT KIT, CHAIN ANCHOR, NO.1 (FRONT) -----	2
6302-21M	BOLT KIT, CHAIN EYE (FRONT) -----	2
6302-22	CHAIN SUB-ASSY (REAR) -----	2
6302-22K	BOLT KIT, CHAIN ANCHOR, NO.1 (REAR) -----	2
6302-22L	BOLT KIT, CHAIN ANCHOR, NO.2 (REAR) -----	2
6302-41	WHEEL, CHAIN (FRONT) -----	2
6302-41A	RING, SHAFT SNAP (FOR FRONT CHAIN WHEEL) ---	2
6302-42	WHEEL, CHAIN (REAR) -----	2
6302-42A	RING, SHAFT SNAP (FOR CHAIN WHEEL) -----	2
6302-45	SUPPORT, CHAIN WHEEL -----	1
6302-AD	NUT, HEXAGON -----	2
6302-AE	WASHER, CHAIN SPECIAL -----	2
6302-AH	COVER, CHAIN WHEEL -----	2
6302-AK	PLATE, CHAIN ANCHOR -----	2
6302-AL	COVER, CHAIN WHEEL -----	4
6302-AQ	BOLT -----	2

6302-026

FIG. 6505 FRONT LIFT CYLINDER

6505

FS

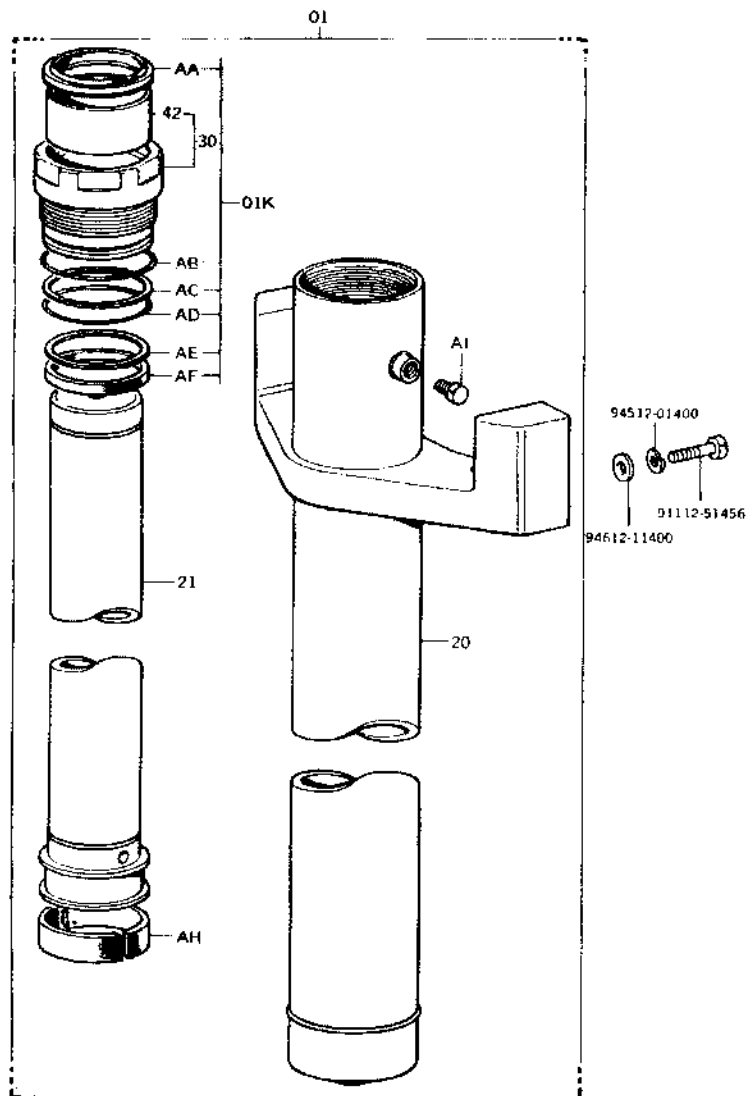

PART NAME CODE	PART NAME	QTY
6505-01	CYLINDER ASSY, LIFT	1
6505-01K	CYLINDER O/H KIT, LIFT	1
6505-20	CYLINDER SUB-ASSY, LIFT	1
6505-21	ROD SUB-ASSY, LIFT CYLINDER	1
6505-30	GUIDE SUB-ASSY, LIFT CYLINDER ROD	1
6505-42	SLEEVE, LIFT CYLINDER ROD GUIDE	1
6505-AA	SEAL, DUST	1
6505-AB	RING, O	1
6505-AC	RING, BACK UP	1
6505-AD	RING, O	1
6505-AE	RING, BACK UP	1
6505-AF	PACKING, U	1
6505-AH	BUSHING	1
6505-A1	PLUG	1

6505-000

(FS) (4)

G210

FIG. 6506 REAR LIFT CYLINDER

6506

FS

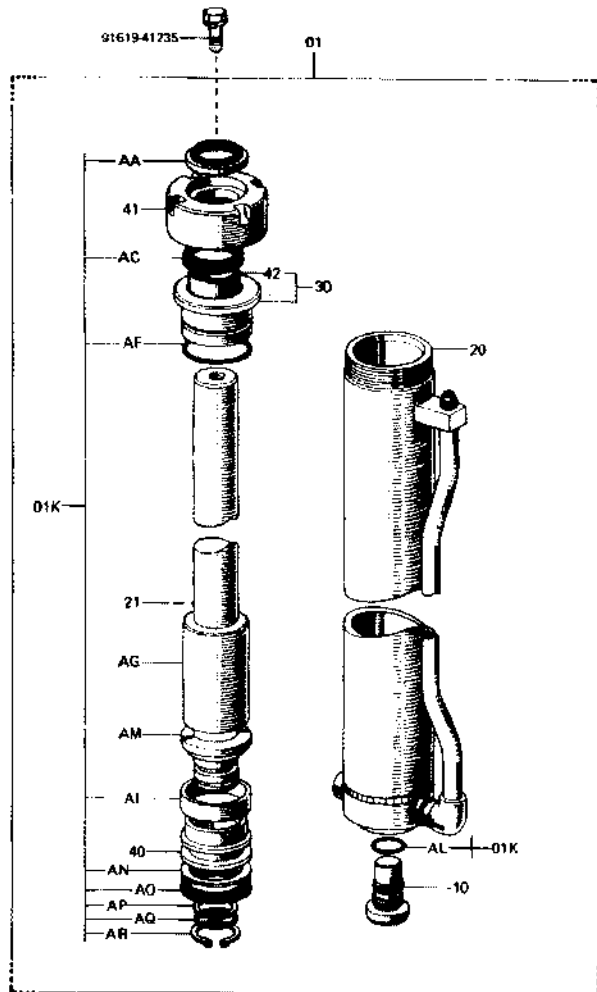

PART NAME CODE	PART NAME	QTY
6506-01	CYLINDER ASSY, LIFT	1
6506-01K	CYLINDER O/H KIT, LIFT	1
6506-10	VALVE ASSY, FLOW REGULATOR	1
6506-20	CYLINDER SUB-ASSY, LIFT	1
6506-21	ROD SUB-ASSY, LIFT CYLINDER	1
6506-30	GUIDE SUB-ASSY, CYLINDER ROD	1
6506-40	PISTON, LIFT CYLINDER	1
6506-41	COVER, LIFT CYLINDER	1
6506-42	SLEEVE, LIFT CYLINDER ROD GUIDE	1
6506-AA	SEAL, DUST	1
6506-AC	PACKING, U	1
6506-AF	RING, O	1
6506-AG	SPACER, LIFT CYLINDER	1
6506-AI	RING, WEAR	1
6506-AL	RING, O	1
6506-AM	RING, STOPPER	1
6506-AN	RING, BACK UP	1
6506-AO	PACKING	1
6506-AP	RING, BACK UP	1
6506-AQ	RING, O	1
6506-AR	RING, SHAFT SNAP	1

(FS) (5)

G210

FIG. 6511 TILT CYLINDER

6511

FS

FS

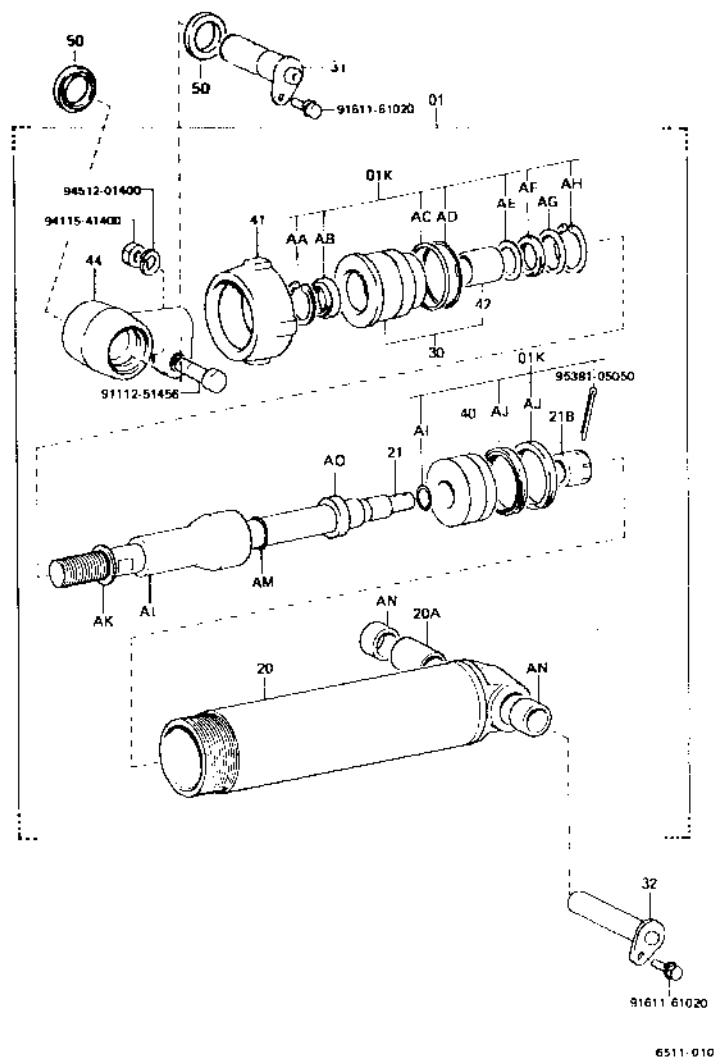

テイルト角度表
TABLE OF TILT RANGE

生産期間 PROD DATE	型式 MODELS	タイヤ TYRE	編高 LIFTING HEIGHT	備考 DESCRIPTION	テイルト角 TILT RANGE
8009-	F, FV, M, SV, V	SINGLE	H2000-H4000		8D-12D
8009	F, FV, M, SV, V	DOUBLE	H2000 H4500		8D-12D
8009	F, FV, M, SV, V	SINGLE	H4500 H5000		8D- 6D
8009-	F, FV, M, SV, V	DOUBLE	H5000		8D- 8D
8009-	F, FV, M, SV, V		H2000	FRONT GLASS	8D-10D
8009-	FSV, FS		H3700 H6500		8D- 6D
8009-	F, FV, M, SV, V	SINGLE	H2000-H4000	AUSTRALIA	3D-12D
8009-	F, FV, M, SV, V	DOUBLE	H2000-H4500	AUSTRALIA	3D-12D
8009-	F, FV, M, SV, V	SINGLE	H4500-H5000	AUSTRALIA	3D- 8D
8009-	F, FV, M, SV, V	DOUBLE	H5000	AUSTRALIA	3D- 6D
8009-	F, FV, M, SV, V		H2000	FRONT GLASS AUSTRALIA	3D-10D
8009-	FV, M, SV, V		H3700-H6500	AUSTRALIA	3D- 6D

6511-019

FIG. 6511 TILT CYLINDER

6511

FS

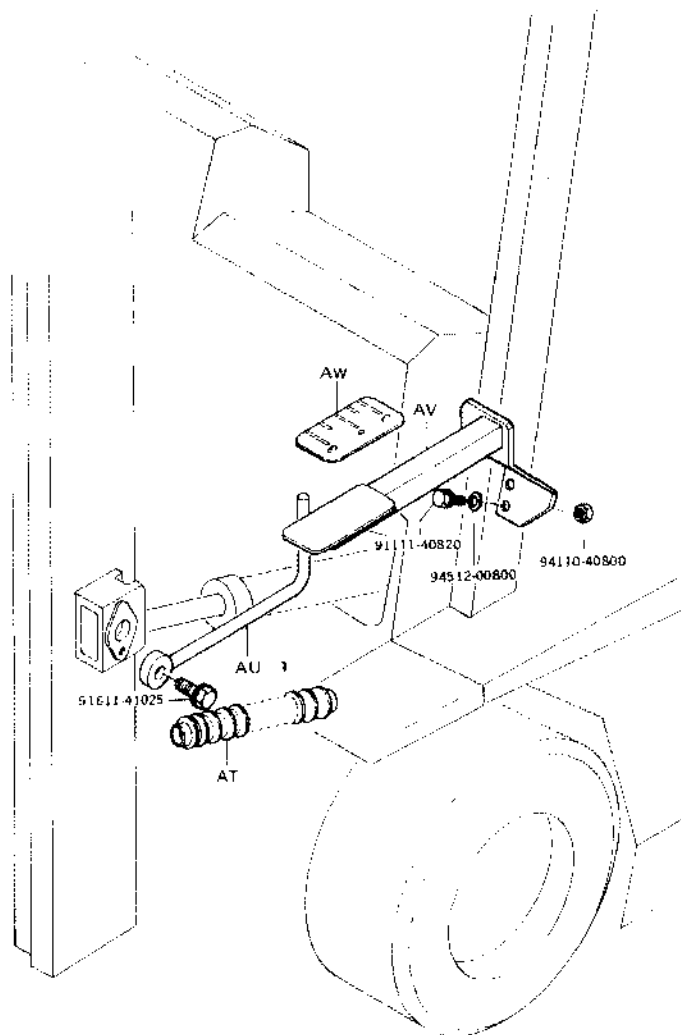

6511 013

PART NAME CODE	PART NAME	QTY
6511-01	CYLINDER ASSY, TILT -----	2
6511-01K	CYLINDER O/H KIT, TILT -----	2
6511-20	CYLINDER SUB-ASSY, TILT -----	2
6511-20A	BUSH, PIN (FOR CYLINDER) -----	2
6511-21	ROD SUB-ASSY, TILT CYLINDER PISTON -----	2
6511-21B	NUT, CASTLE -----	2
6511-30	GUIDE SUB-ASSY, TILT CYLINDER ROD -----	2
6511-31	PIN SUB-ASSY, TILT CYLINDER -----	2
6511-32	PIN SUB-ASSY, TILT CYLINDER, RR -----	2
6511-40	PISTON, TILT CYLINDER -----	2
6511-41	COVER, TILT CYLINDER -----	2
6511-42	SLEEVE, TILT CYLINDER ROD GUIDE -----	2
6511-44	JOINT, PISTON ROD -----	2
6511-50	SEAL, GREASE -----	2
6511-AA	RING, HOLE SNAP -----	2
6511-AB	SEAL, DUST -----	2
6511-AC	RING, BACK UP -----	2
6511-AD	RING, O -----	2
6511-AE	RING, BACK UP -----	2
6511-AF	PACKING, U -----	2
6511-AG	PLATE, STOPPER -----	2
6511-AH	RING, HOLE SNAP -----	2
6511-AI	RING, O -----	2
6511-AJ	PACKING, U -----	4
6511-AK	SHIM, TILT CONTROL -----	99
6511-AL	SPACER, TILT CONTROL -----	2
6511-AM	RING, O -----	4
6511-AN	COLLAR -----	4
6511-AO	SPACER, TILT CONTROL -----	2
6511-AT	BOOT SUB-ASSY -----	2
6511-AU	BAR SUB-ASSY, TILT GAUGE -----	1
6511-AV	BRACKET SUB-ASSY, TILT GAUGE -----	1
6511-AW	PLATE, TILT CYLINDER INDICATOR -----	1

FIG. 6701 OIL PUMP

6701

FS

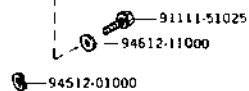
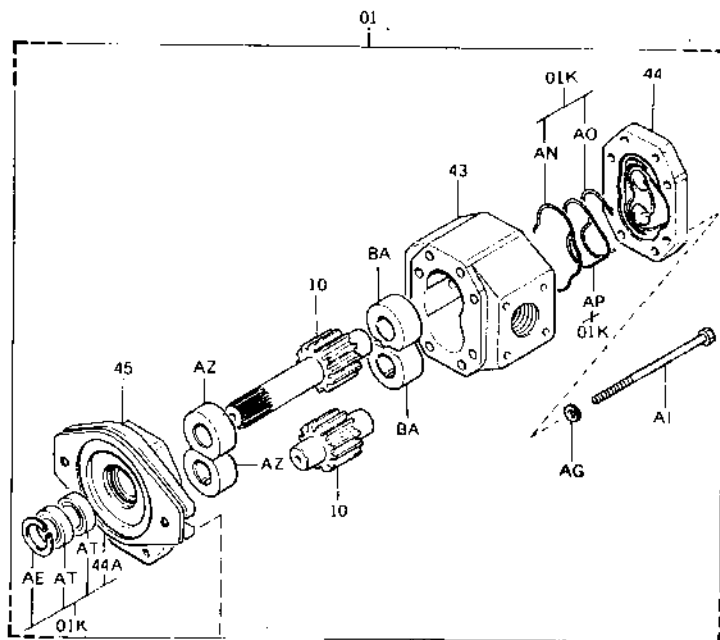

6701-018

PART NAME CODE	PART NAME	QTY
6701-01	PUMP ASSY, OIL -----	1
6701 01K	PUMP D/H KIT, OIL -----	1
6701-10	GEAR SET -----	1
6701-11	BUSH SET, NO.1 -----	2
6701-43	BODY -----	1
6701-44	FLANGE, MOUNTING -----	1
6701-45	COVER -----	1
6701-AA	SEAL, BUSHING -----	2
6701-AB	RING, BACKING, RH -----	2
6701-AC	RING, BACKING, LH -----	2
6701-AD	SEAL, OIL -----	1
6701-AE	RING, SNAP -----	1
6701-AF	BOLT -----	4
6701-AG	WASHER, SPRING -----	4
6701-AH	SEAL, BODY -----	2
6701-AI	BOLT -----	2

(FS) (7)

G210

FIG. 6705 OIL CONTROL VALVE

6705

FS

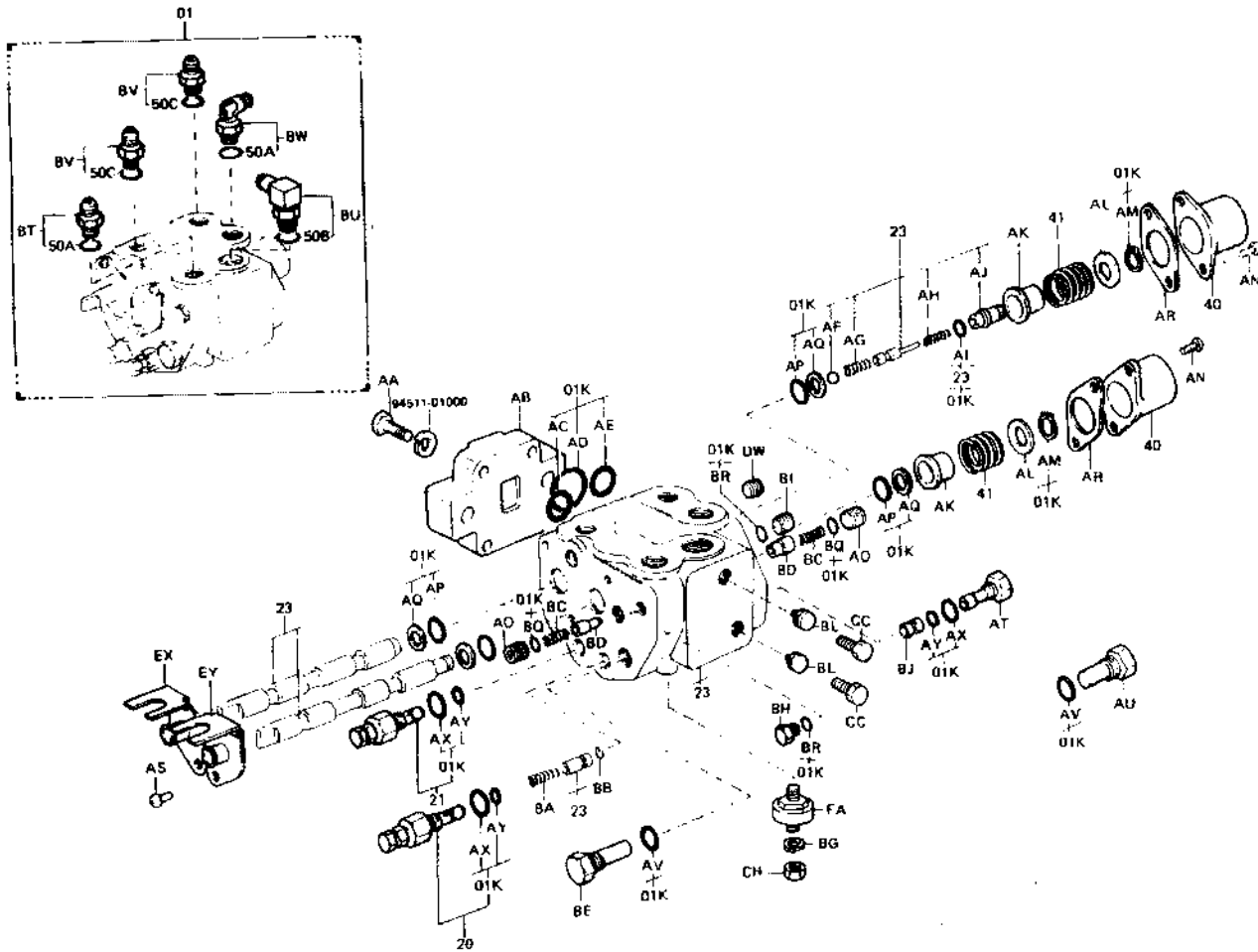

6705-050



FIG. 6705 OIL CONTROL VALVE

6705

FS (3-WAY..UL-EE)

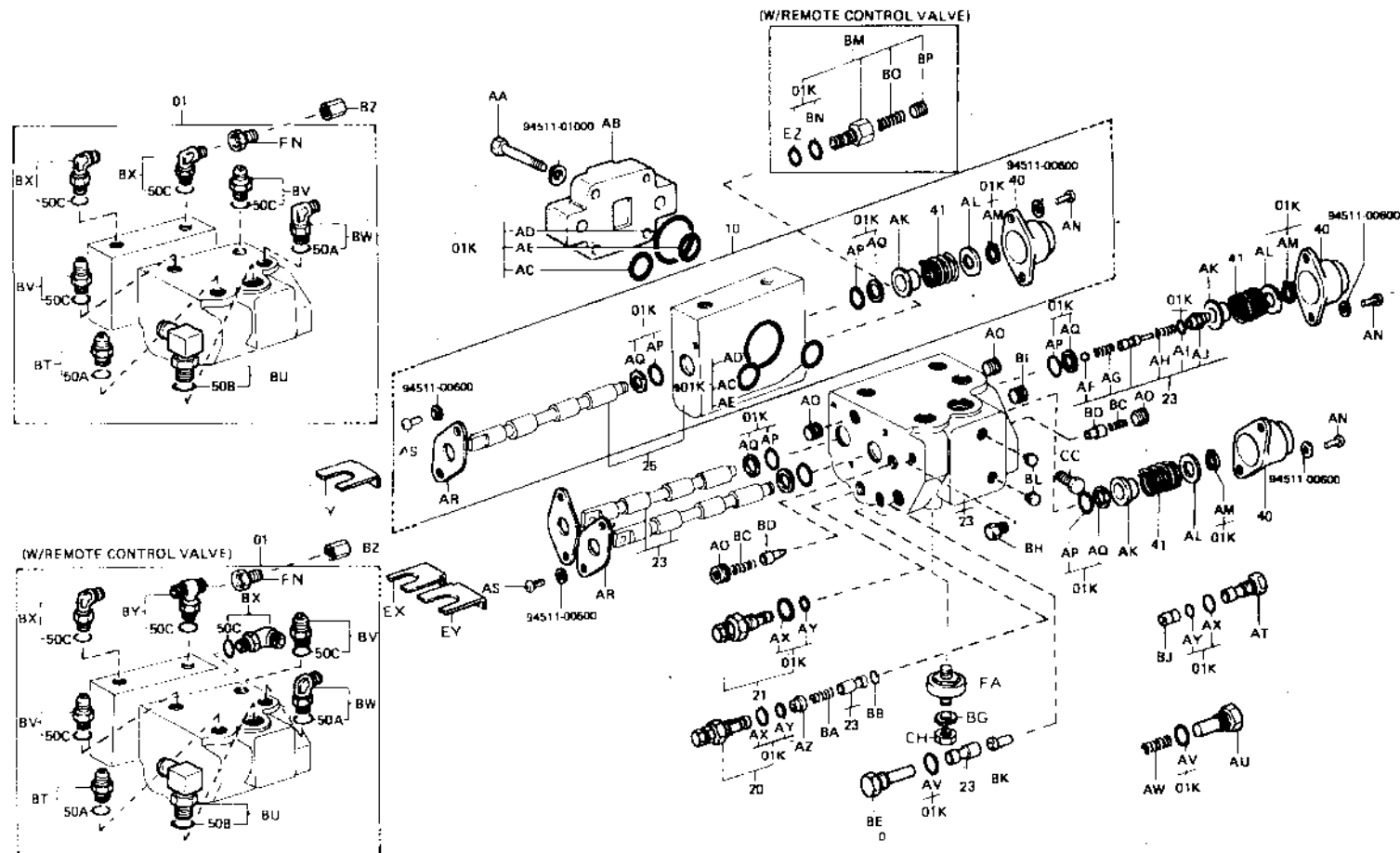

FIG. 6705 OIL CONTROL VALVE

6705

FS (3-WAY)

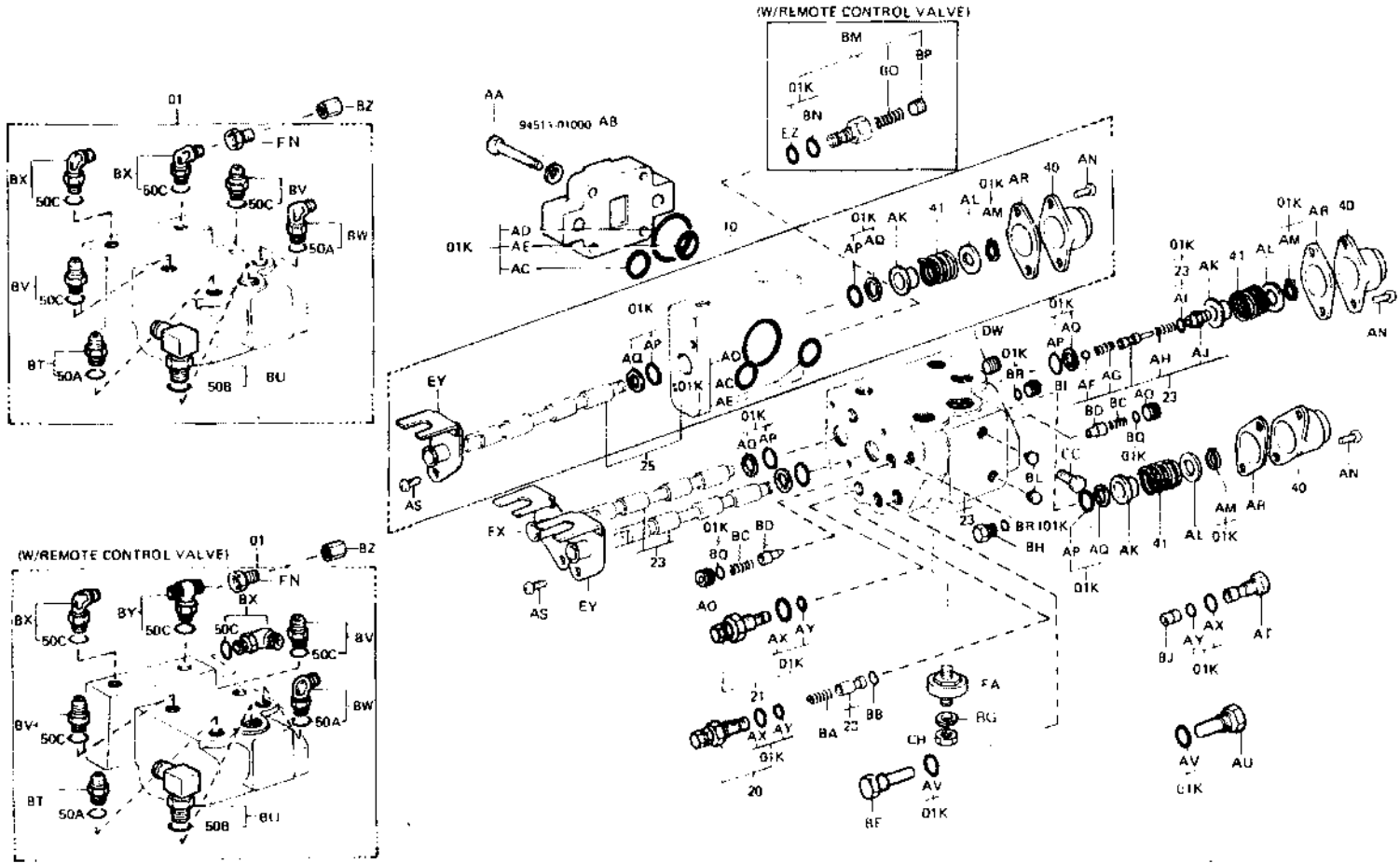

FIG. 6705 OIL CONTROL VALVE

6705

FS (4-WAY)

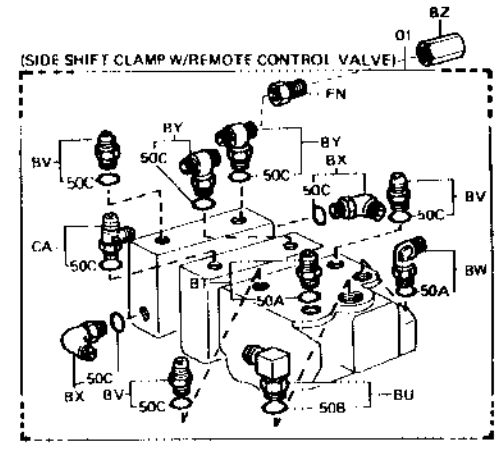
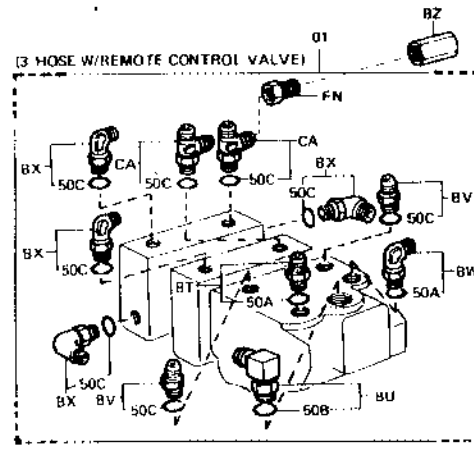
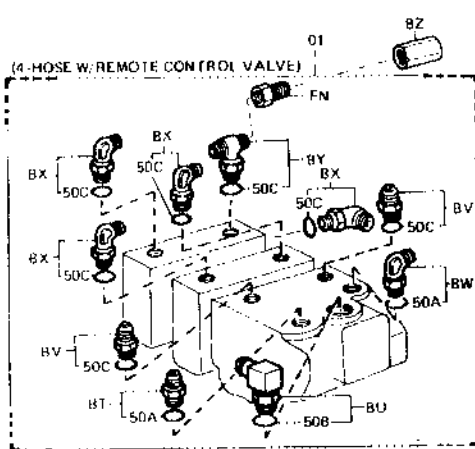
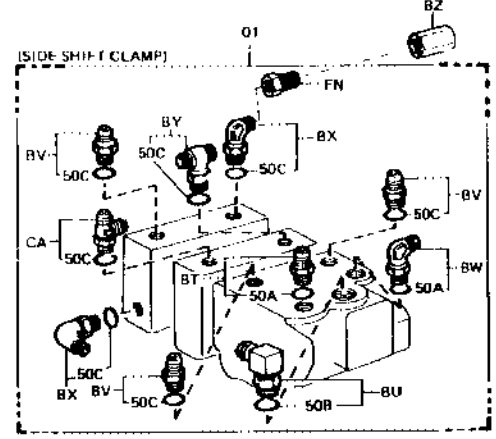
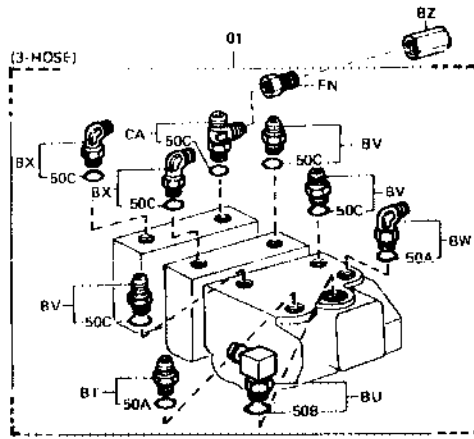
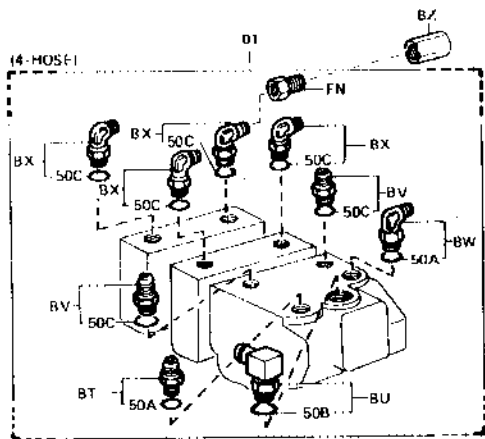

FIG. 6705 OIL CONTROL VALVE

6705

FS (4-WAY..UL-EE)

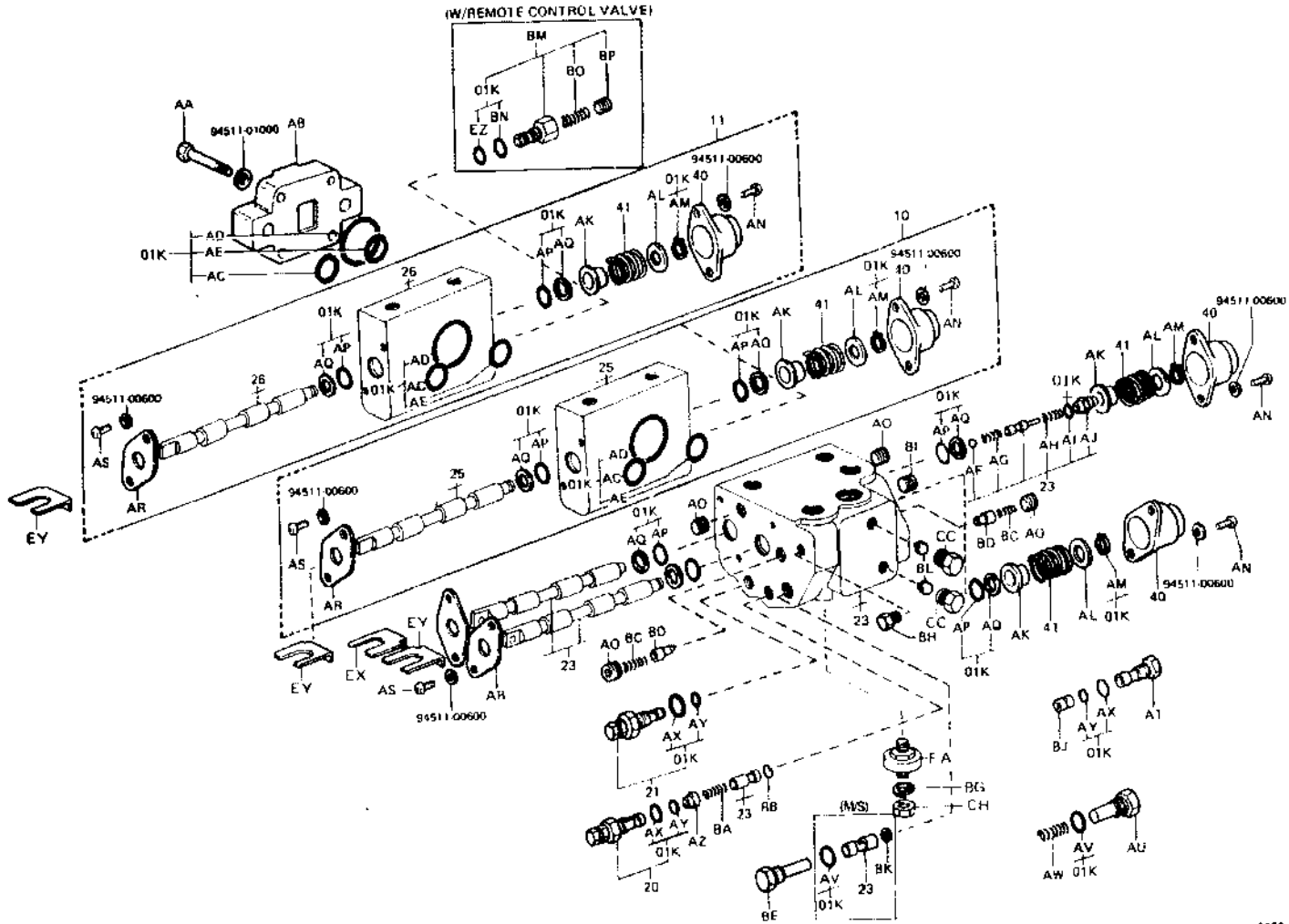
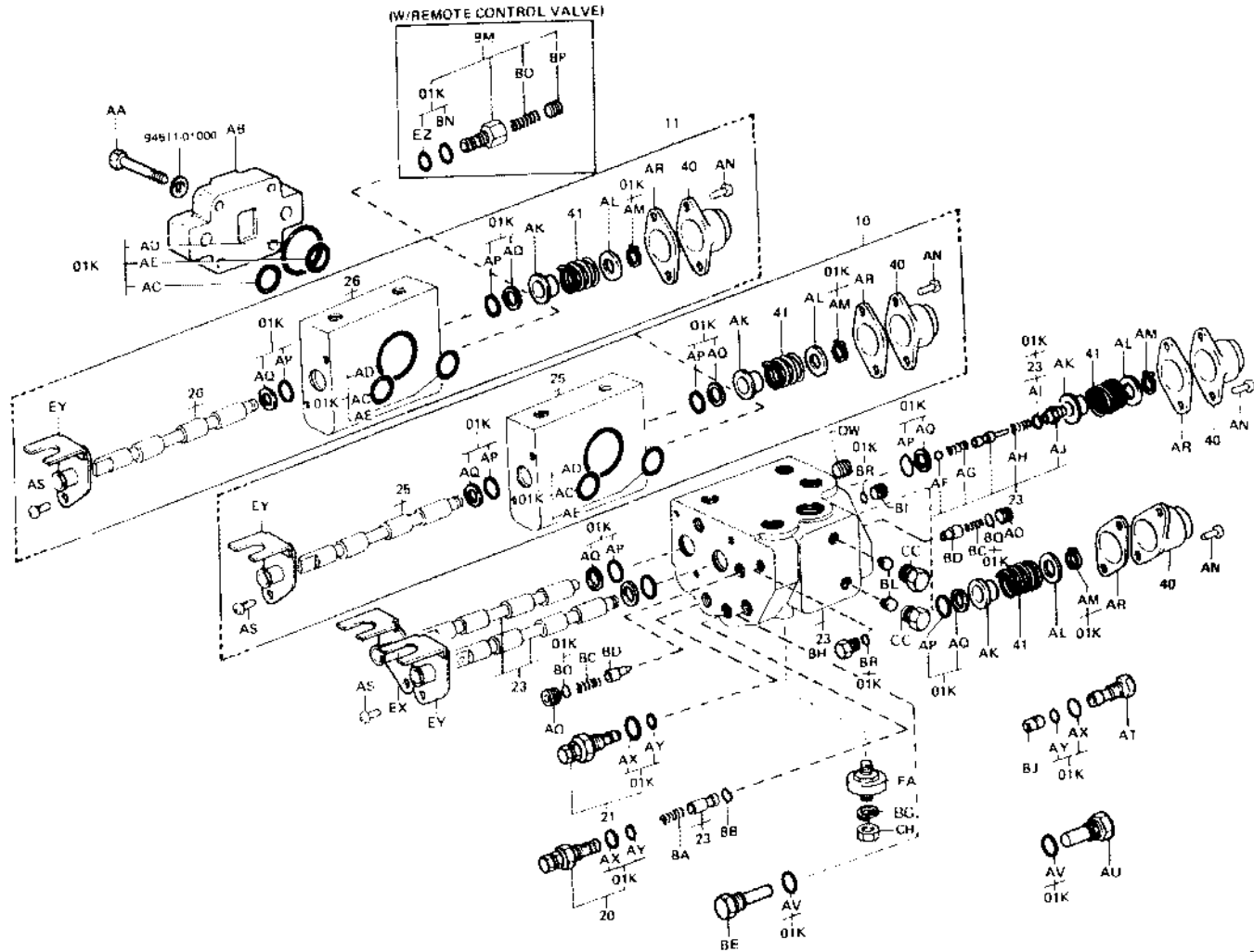

FIG. 6705 OIL CONTROL VALVE

6705

FS (4-WAY)



6705

PART NAME CODE	PART NAME	QTY
6705-01	VALVE ASSY, OIL CONTROL -----	1
6705-01K	VALVE O/H KIT, OIL CONTROL -----	1
6705-10	VALVE ASSY, PLUNGER SECTION, NO.1 -----	1
6705-11	VALVE ASSY, PLUNGER SECTION, NO.2 -----	1
6705-20	VALVE SET, PILOT RELIEF, NO.1 -----	1
6705-21	VALVE SET, PILOT RELIEF, NO.2 -----	1
6705-23	HOUSING & SPOOL SET, NO.1 -----	1
6705-25	HOUSING & SPOOL SET, ATTACHMENT, NO.1 -----	1
6705-26	HOUSING & SPOOL SET, ATTACHMENT, NO.2 -----	1
6705-40	COVER, SPRING -----	2
6705-41	SPRING, COMPRESSION (FOR SPOOL RETURN) -----	2
6705-50A	RING, O, NO.1 (FOR VALVE FITTING) -----	2
6705-50B	RING, O, NO.2 (FOR VALVE FITTING) -----	1
6705-50C	RING, O, NO.3 (FOR VALVE FITTING) -----	2
6705-AA	BOLT -----	4
6705-AB	HOUSING, OUTLET -----	1
6705-AC	RING, O -----	1
6705-AD	RING, O -----	1
6705-AE	RING, O -----	1
6705-AF	BALL, STEEL -----	1
6705-AG	SPRING -----	1
6705-AH	SPRING, COMPRESSION -----	1
6705-AI	RING, O -----	1
6705-AJ	STOPPER -----	1
6705-AK	HOLDER, SPRING -----	2
6705-AL	WASHER, PLATE -----	2
6705-AM	RING, SHAFT SNAP -----	2
6705-AN	SCREW -----	4
6705-AO	PLUG -----	2
6705-AP	RING, O -----	4
6705-AQ	RING, BACK UP -----	4
6705-AR	HOLDER, SEAL -----	2
6705-AS	SCREW -----	4
6705-AT	STOPPER -----	1
6705-AU	STOPPER -----	1
6705-AV	RING, O -----	2
6705-AX	RING, O -----	3
6705-AY	RING, O -----	3
6705-BA	SPRING, COMPRESSION -----	1
6705-BB	WIRE, ORIFICE TURNING -----	1
6705-BC	SPRING, COMPRESSION -----	2
6705-BD	PLUNGER, CHECK -----	2
6705-BE	STOPPER -----	1
6705-BG	WASHER -----	4
6705-BH	PLUG -----	1
6705-BI	PLUG -----	1
6705-BJ	SEAT, VALVE -----	1
6705-BL	SEAT, INSERT -----	2
6705-BM	VALVE SUB-ASSY, RELIEF -----	1
6705-BN	RING, O -----	1
6705-BO	SPRING -----	1
6705-BP	STOPPER -----	1
6705-BQ	RING, O -----	2

(FS) (B) G210

PART NAME CODE	PART NAME	QTY
6705-BR	RING, O -----	2
6705-BT	FITTING -----	1
6705-BU	FITTING -----	1
6705-BV	FITTING -----	2
6705-BW	FITTING -----	1
6705-BX	FITTING -----	2
6705-BY	FITTING -----	1
6705-BZ	PLUG -----	2
6705-CA	FITTING -----	1
6705-CC	PLUG -----	2
6705-CH	NUT -----	4
6705-DW	PLUG -----	1
6705-EX	BRACKET SUB-ASSY, TILT -----	1
6705-EY	BRACKET SUB-ASSY, LIFT -----	1
6705-EZ	RING, O -----	1
6705-FA	INSULATOR -----	4
6705-FN	FITTING -----	2

(FS) (9) G210

FIG. 6709 OIL CONTROL VALVE LINK

6709

FS

FS (3-WAY)

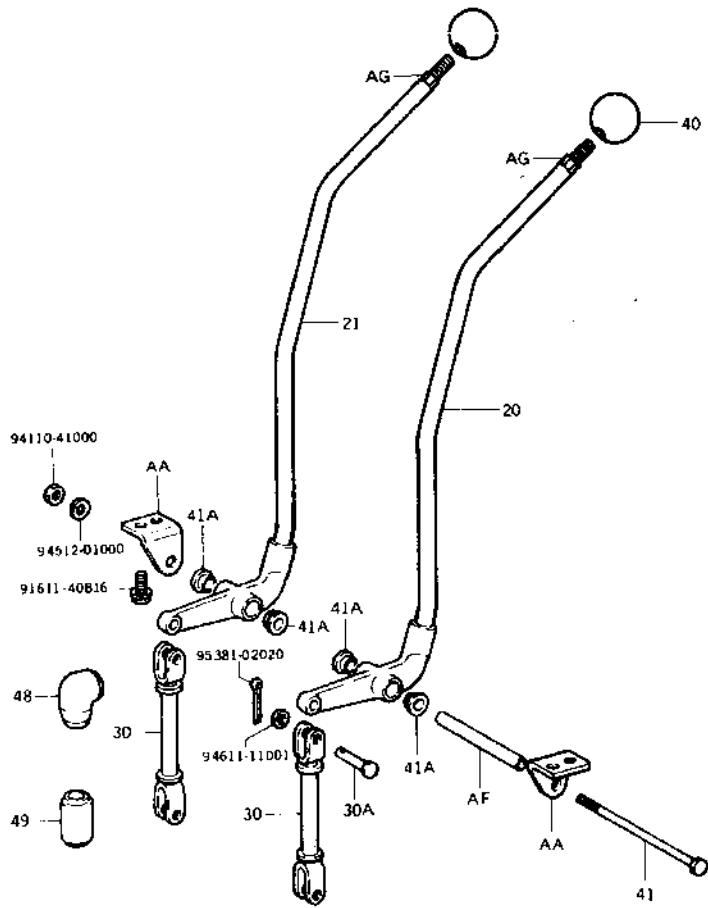

6709 016

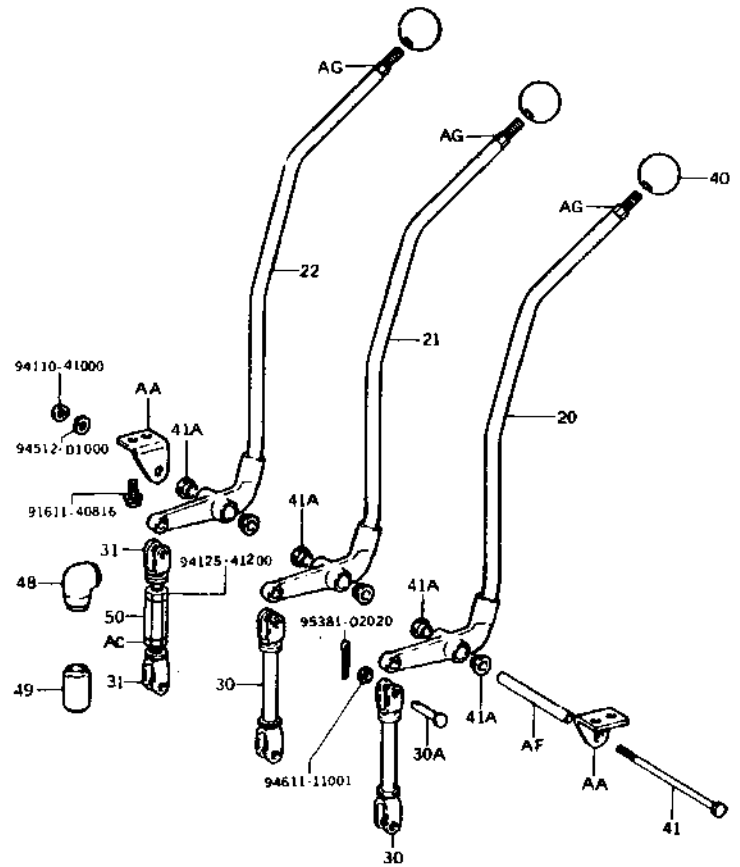

6709-017

FIG. 8709 OIL CONTROL VALVE LINK

6709

FS (4-WAY)

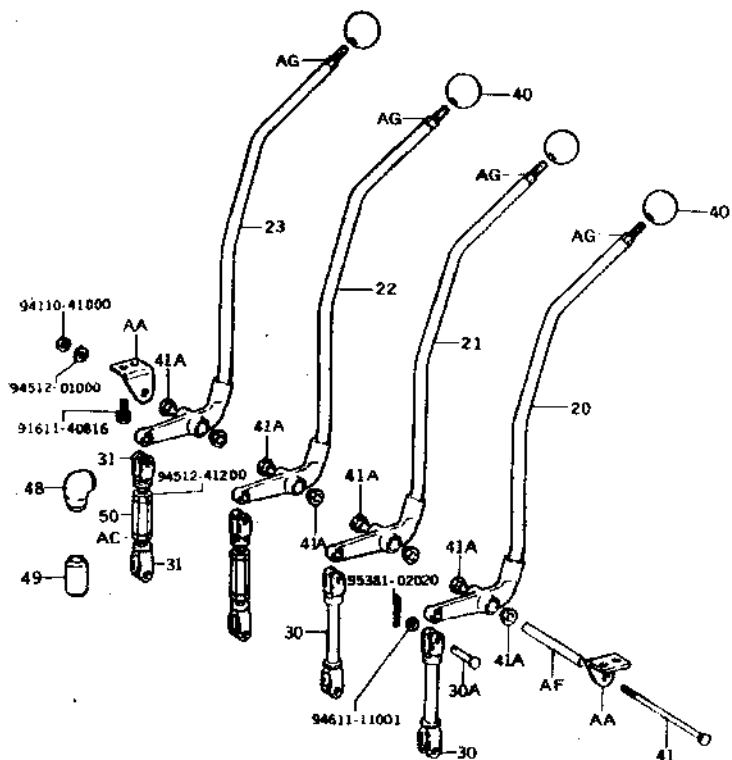

6709-018

PART NAME CODE	PART NAME	QTY
6709-20	LEVER SUB-ASSY, CONTROL VALVE, NO.1	1
6709-21	LEVER SUB-ASSY, CONTROL VALVE, NO.2	1
6709-22	LEVER SUB-ASSY, CONTROL VALVE, NO.3	1
6709-23	LEVER SUB-ASSY, CONTROL VALVE, NO.4	1
6709-30	ROD SUB-ASSY, CONTROL VALVE LEVER, NO.1	2
6709-30A	PIN (FOR CONTROL VALVE LEVER ROD)	4
6709-31	ROD SUB-ASSY, CONTROL VALVE LEVER, NO.2	1
6709-40	KNOB, OIL CONTROL VALVE LEVER	2
6709-41	PIN, OIL CONTROL VALVE LEVER	1
6709-41A	BUSH (FOR LEVER PIN)	4
6709-48	BOOT, CONTROL VALVE LINK, NO.1	2
6709-49	BOOT, CONTROL VALVE LINK, NO.2	2
6709-50	TURNBUCKLE	1
6709-AA	BRACKET SUB-ASSY	1
6709-AC	NUT	1
6709-AF	SPACER	1
6709-AG	BOLT, STUD	2

(FS) (10)

G210

FIG. 8801 BODY PIPING

6801

FS

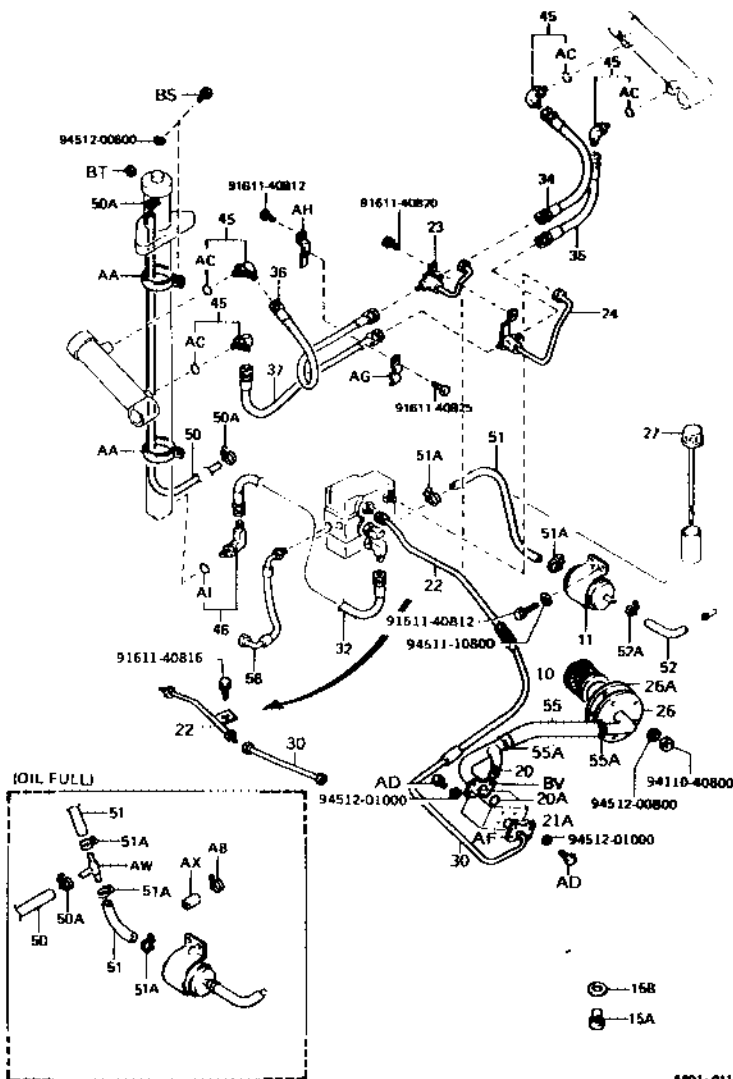

PART NAME CODE	PART NAME	QTY
6801-10	FILTER ASSY, SUCTION	1
6801-11	FILTER ASSY, RETURN	1
6801-15A	PLUG (FOR OIL TANK DRAIN)	1
6801-15B	GASKET (FOR OIL TANK DRAIN PLUG)	1
6801-20	PIPE SUB-ASSY (PUMP INLET)	1
6801-20A	RING, O (FOR OIL PUMP INLET)	1
6801-21A	RING, O (FOR OIL PUMP OUTLET)	1
6801-22	PIPE SUB-ASSY (PUMP TO VALVE)	1
6801-23	PIPE SUB-ASSY (TILT CYLINDER FRONT)	1
6801-24	PIPE SUB-ASSY (TILT CYLINDER REAR)	1
6801-26	OUTLET SUB-ASSY, OIL TANK	1
6801-26A	PACKING, OIL TANK COVER	1
6801-27	CAP SUB-ASSY, OIL TANK	1
6801-30	HOSE, HIGH PRESSURE, NO.1 (PUMP TO VALVE)	1
6801-32	HOSE, HIGH PRESSURE, NO.1 (VALVE TO LIFT)	1
6801-34	HOSE, HIGH PRESSURE, NO.1 (TILT FRONT)	1
6801-35	HOSE, HIGH PRESSURE, NO.1 (TILT REAR)	1
6801-36	HOSE, HIGH PRESSURE, NO.2 (TILT FRONT)	1
6801-37	HOSE, HIGH PRESSURE, NO.2 (TILT REAR)	1
6801-45	FITTING (FOR TILT CYLINDER)	2
6801-46	FITTING (FOR LIFT CYLINDER)	1
6801-50	HOSE, LOW PRESSURE, NO.1 (LIFT TO TANK)	1
6801-50A	CLAMP (FOR LIFT TO TANK NO.1 HOSE)	2
6801-51A	CLAMP (FOR VALVE TO TANK NO.1 HOSE)	2
6801-52	HOSE, LOW PRESSURE, NO.2 (VALVE TO TANK)	1
6801-52A	CLAMP (FOR VALVE TO TANK NO.2 HOSE)	2
6801-55	HOSE, LOW PRESSURE (TANK TO PUMP)	1
6801-55A	CLAMP (FOR TANK TO PUMP HOSE)	2
6801-56	HOSE, LOW PRESSURE (STEERING TO VALVE)	1
6801-AA	BAND, LIFT CYLINDER OVERFLOW HOSE	2
6801-AC	RING, O	4
6801-AD	BOLT	8
6801-AF	FLANGE, SPLIT	1
6801-AG	CLAMP	1
6801-AH	BRACKET SUB-ASSY, TILT HOSE	1
6801-BS	BOLT	1
6801-BT	WASHER	1
6801-BV	FLANGE	2

(FS) (11)

G210

FIG. 6802 MAST PIPING

6802

FS

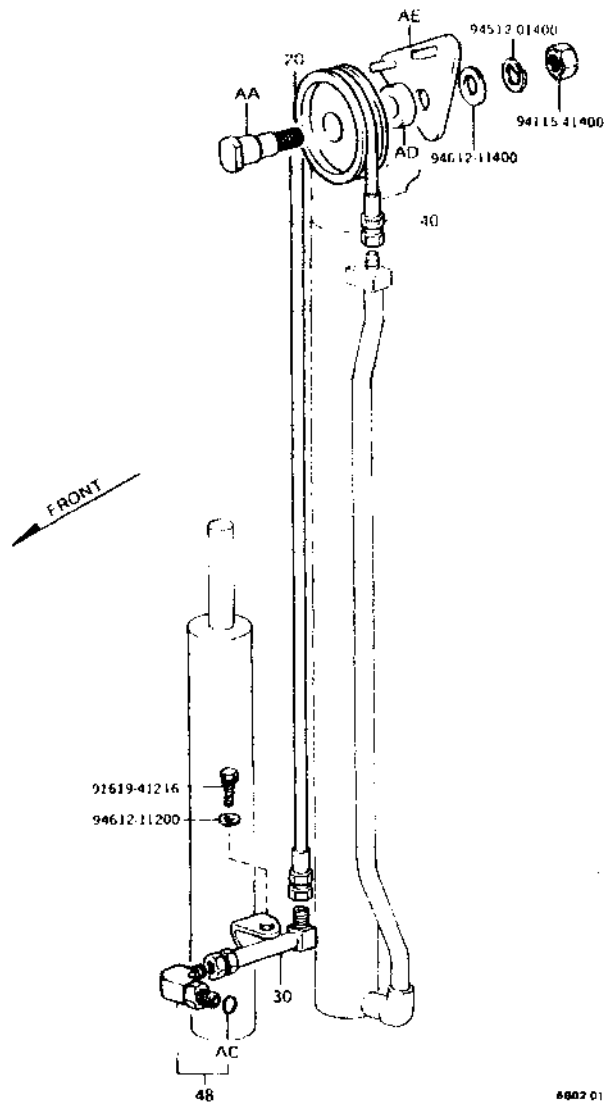

6802 017A

PART NAME CODE	PART NAME	QTY
6802-20	PULLEY SUB-ASSY, HOSE GUIDE, NO.1 -----	1
6802-20	PIPE SUB-ASSY, NO.1 (FRONT LIFT) -----	1
6802-40	HOSE, HIGH PRESSURE (FRONT LIFT PULLEY) -----	1
6802-48	FITTING (FOR FRONT LIFT CYLINDER) -----	1
6802-AA	PIN, HOSE GUIDE PULLEY -----	1
6802-AC	RING, O -----	1
6802-AD	COLLAR -----	1
6802-AE	STOPPER SUB-ASSY, HIGH PRESSURE HOSE -----	1
6802-AR	RING, O -----	1

(FS) (12)

G210

FIG. 6101 MAST

6101

FSV

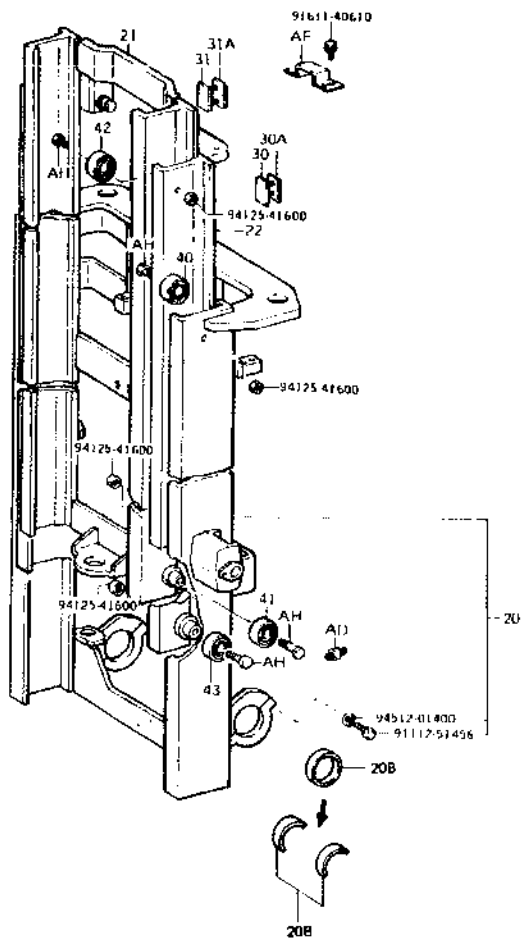

6101 051

PART NAME CODE	PART NAME	QTY
6101-20	MAST SUB-ASSY, OUTER -----	1
6101-20B	BUSH, MAST SUPPORT -----	1
6101-21	MAST SUB-ASSY, INNER -----	1
6101-22	MAST SUB-ASSY, MIDDLE -----	1
6101-30	STRIP SUB-ASSY, OUTER MAST -----	2
6101-30A	SHIM, OUTER MAST STRIP -----	99
6101-31	STRIP SUB-ASSY, MIDDLE MAST -----	2
6101-31A	SHIM, MIDDLE MAST STRIP -----	99
6101-40	ROLLER, LIFT (FOR OUTER MAST) -----	2
6101-41	ROLLER, LIFT (FOR INNER MAST) -----	2
6101-42	ROLLER, LIFT (FOR MIDDLE MAST UPPER) -----	2
6101-43	ROLLER, LIFT (FOR MIDDLE MAST LOWER) -----	2
6101-AD	FITTING, GREASE -----	2
6101-AF	COVER, ROLLER -----	2
6101-AH	BOLT -----	8

(FSV) (1)

G210

FIG. 6301 LIFT BRACKET & FORK

6301

FSV

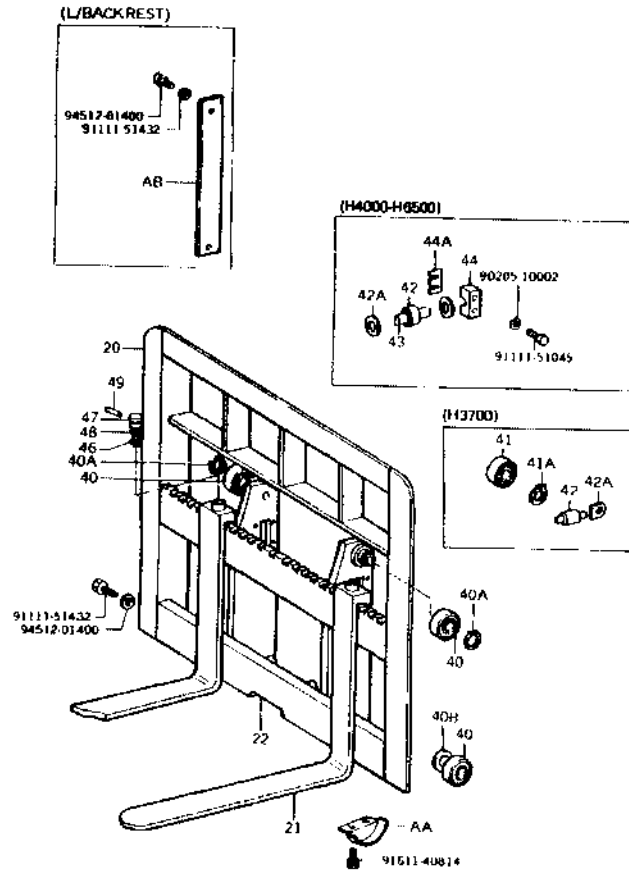

6301-040

PART NAME CODE	PART NAME	QTY
6301-20	BACKREST SUB-ASSY -----	1
6301-21	FORK SUB-ASSY -----	2
6301-22	BRACKET SUB-ASSY, LIFT -----	1
6301-40	ROLLER, LIFT (UPPER, LOWER) -----	4
6301-40A	RING, SHAFT SNAP (UPPER, LOWER) -----	2
6301-40B	SHIM, LIFT ROLLER -----	99
6301-41	ROLLER, LIFT (CENTER) -----	2
6301-41A	RING, SHAFT SNAP (CENTER) -----	2
6301-42	ROLLER, SIDE -----	2
6301-42A	SHIM (FOR SIDE ROLLER) -----	4
6301-43	SHAFT, SIDE ROLLER -----	2
6301-44	HOLDER, SIDE ROLLER SHAFT -----	4
6301-44A	SHIM (FOR SHAFT HOLDER) -----	99
6301-46	PIN, FORK STOPPER -----	2
6301-47	KNOB, FORK STOPPER PIN -----	2
6301-48	SPRING, FORK STOPPER PIN -----	2
6301-49	PIN, SPRING (FOR FORK STOPPER PIN) -----	2
6301-AA	COVER, LIFT BRACKET ROLLER -----	4
6301-AB	PLATE, SIDE -----	2

(FSV) (2)

G210

FIG. 6302 CHAIN & CHAIN WHEEL

6302

FSV

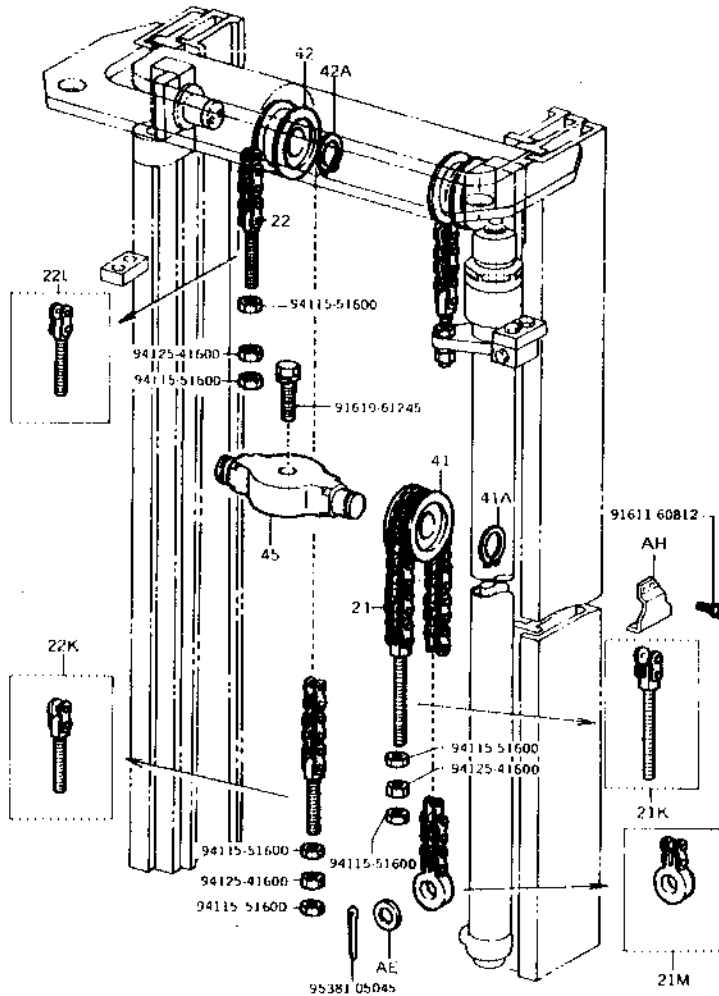

6302-010

PART NAME CODE	PART NAME	QTY
6302-21	CHAIN SUB-ASSY (FRONT) -----	2
6302-21K	BOLT KIT, CHAIN ANCHOR, NO.1 (FRONT) -----	2
6302-21M	BOLT KIT, CHAIN EYE (FRONT) -----	2
6302-22	CHAIN SUB-ASSY (REAR) -----	2
6302-22K	BOLT KIT, CHAIN ANCHOR, NO.1 (REAR) -----	2
6302-22L	BOLT KIT, CHAIN ANCHOR, NO.2 (REAR) -----	2
6302-41	WHEEL, CHAIN (FRONT) -----	2
6302-41A	RING, SHAFT SNAP (FOR FRONT CHAIN WHEEL) -----	2
6302-42	WHEEL, CHAIN (REAR) -----	2
6302-42A	RING, SHAFT SNAP (FOR CHAIN WHEEL) -----	2
6302-45	SUPPORT, CHAIN WHEEL -----	1
6302-AE	WASHER, CHAIN SPECIAL -----	2
6302-AH	COVER, CHAIN WHEEL -----	2

(FSV) (3)

G210

FIG. 6502 FRONT LIFT CYLINDER

6502

FSV

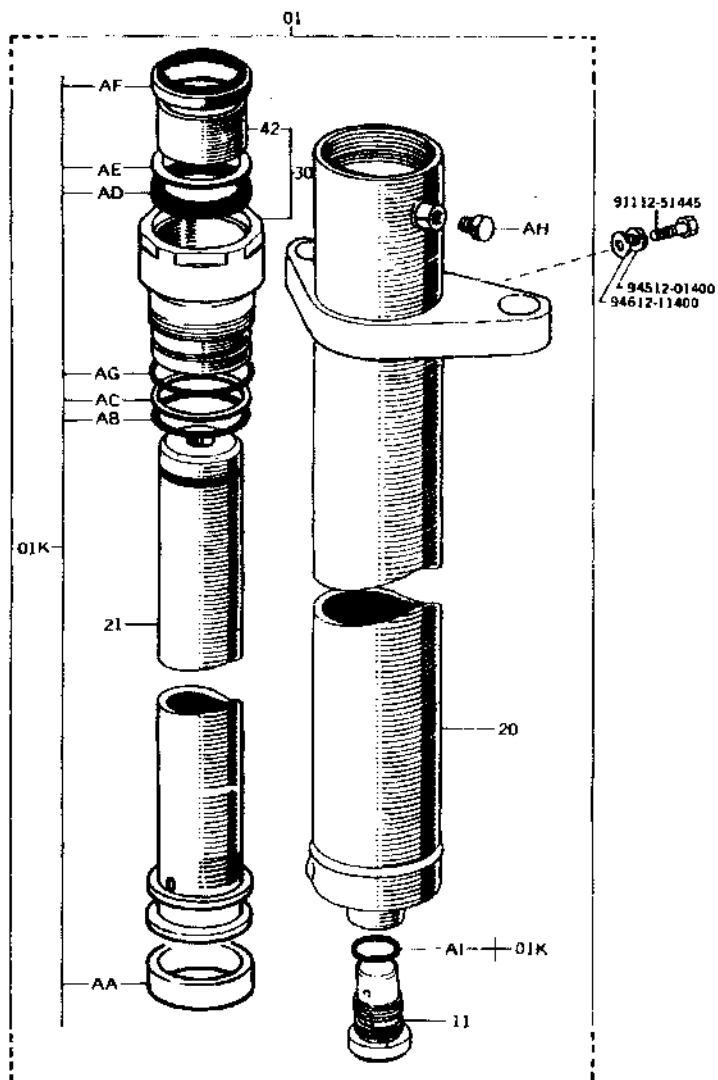

6502 009

PART NAME CODE	PART NAME	QTY
6502-01	CYLINDER ASSY, LIFT	1
6502-01K	CYLINDER D/H KIT, LIFT	1
6502-11	VALVE ASSY, SAFETY DOWN	1
6502-20	CYLINDER SUB-ASSY, LIFT	1
6502-21	ROD SUB-ASSY, LIFT CYLINDER	1
6502-30	GUIDE SUB-ASSY, LIFT CYLINDER ROD	1
6502-42	SLEEVE, LIFT CYLINDER ROD GUIDE	1
6502-AA	BUSHING	1
6502-AB	RING, O	1
6502-AC	RING, BACK UP	1
6502-AD	PACKING, U	1
6502-AE	RING, BACK UP	1
6502-AF	SEAL, DUST	1
6502-AG	RING, O	1
6502-AH	PLUG	1
6502-AI	RING, O	1

(FSV) (4)

G210

FIG. 6503 REAR LIFT CYLINDER

6503

FSV

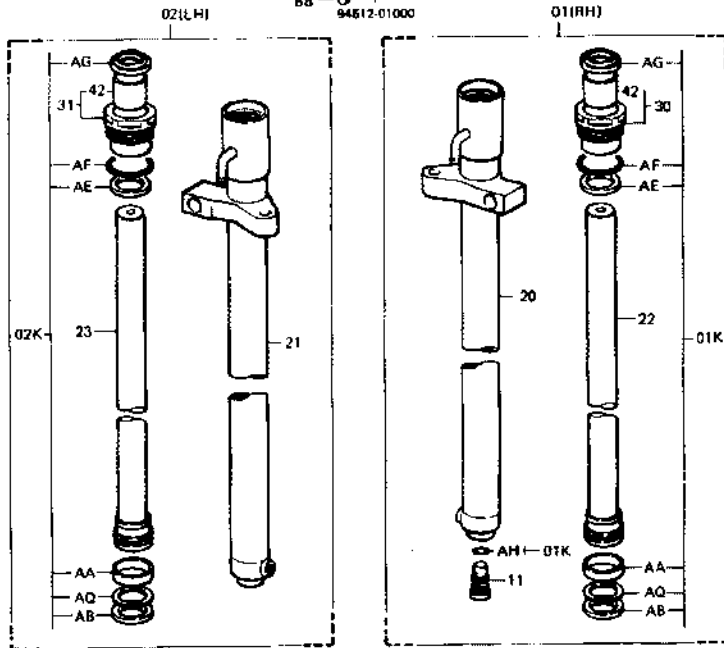
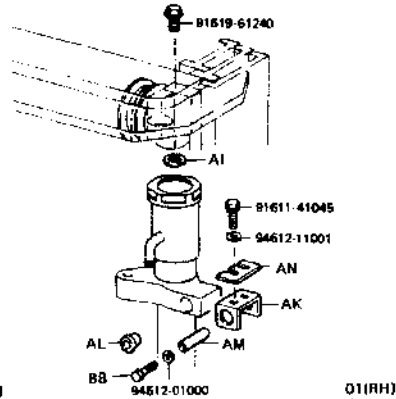

9903-0106

PART NAME CODE	PART NAME	QTY
6503-01	CYLINDER ASSY, LIFT, RH	1
6503-01K	CYLINDER O/H KIT, LIFT, RH	1
6503-02	CYLINDER ASSY, LIFT, LH	1
6503-02K	CYLINDER O/H KIT, LIFT, LH	1
6503-11	VALVE ASSY, SAFETY DOWN	1
6503-20	CYLINDER SUB-ASSY, LIFT, RH	1
6503-21	CYLINDER SUB-ASSY, LIFT, LH	1
6503-22	ROD SUB-ASSY, LIFT CYLINDER, RH	1
6503-23	ROD SUB-ASSY, LIFT CYLINDER, LH	1
6503-30	GUIDE SUB-ASSY, LIFT CYLINDER ROD, RH	1
6503-31	GUIDE SUB-ASSY, LIFT CYLINDER ROD, LH	1
6503-42	SLEEVE, LIFT CYLINDER ROD GUIDE	2
6503-AA	RING, WEAR	2
6503-AB	PACKING, U	2
6503-AE	PACKING, U	2
6503-AF	RING, O	2
6503-AG	SEAL, DUST	2
6503-AH	RING, O	1
6503-A1	SHIM	2-3
6503-AK	BRACKET SUB-ASSY, LIFT CYLINDER	2
6503-AL	BUSHING	4
6503-AM	SPACER	2
6503-AN	SHIM	99
6503-AP	PLUG	2
6503-AQ	RING, BACK UP	2
6503-BB	BOLT	2

(FSV) (5)

G210

FIG. 8511 TILT CYLINDER

6511

FSV

FSV

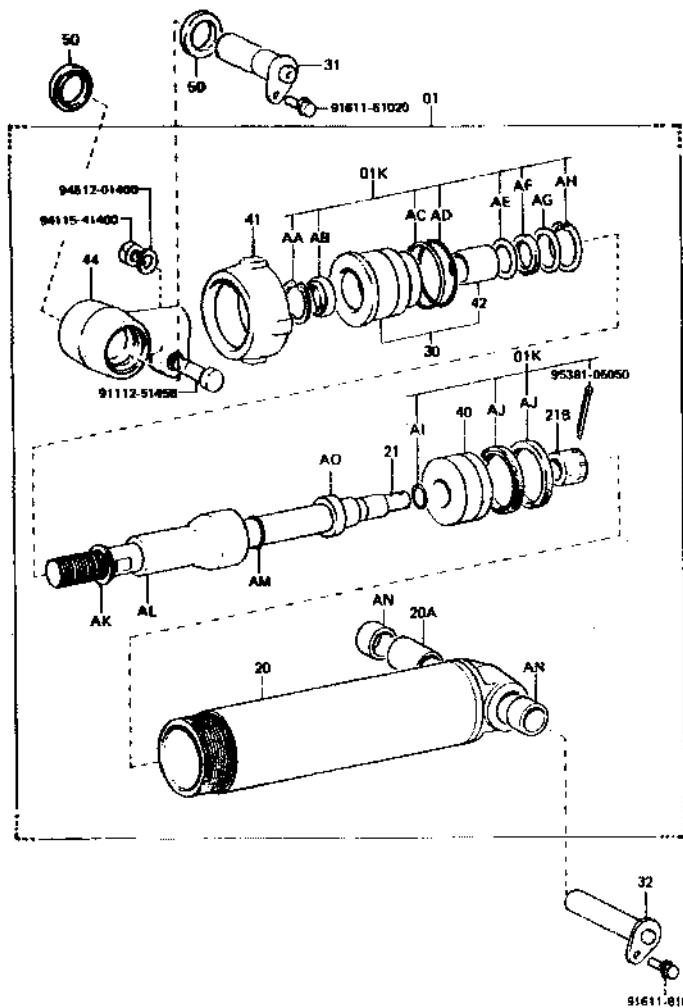

91611-81020

6511-010

テイルト角度表
TABLE OF TILT RANGE

生産期間 PROD DATE	型式 MODELS	タイヤ TIRE	幅 高 LIFTING HEIGHT	備 考 DESCRIPTION	テイルト角 TILT RANGE
8009-	F, FV, M, SV, V	SINGLE	H2000-H4000		6D - 12D
8009-	F, FV, M, SV, V	DOUBLE	H2000-H4500		6D - 12D
8009-	F, FV, M, SV, V	SINGLE	H4500-H5000		6D - 8D
8009-	F, FV, M, SV, V	DOUBLE	H5000		6D - 8D
8009-	F, FV, M, SV, V		H2000	FRONT GLASS	6D - 10D
8009-	FSV, FS		H3700-H6500		6D - 6D
8009-	F, FV, M, SV, V	SINGLE	H2000-H4000	AUSTRALIA	3D - 12D
8009-	F, FV, M, SV, V	DOUBLE	H2000-H4500	AUSTRALIA	3D - 12D
8009-	F, FV, M, SV, V	SINGLE	H4500-H5000	AUSTRALIA	3D - 6D
8009-	F, FV, M, SV, V	DOUBLE	H5000	AUSTRALIA	3D - 6D
8009-	F, FV, M, SV, V		H2000	FRONT GLASS AUSTRALIA	3D - 10D
8009-	FV, M, SV, V		H3700-H6500	AUSTRALIA	3D - 6D

6511-019

FIG. 6511 TILT CYLINDER

6511

FSV

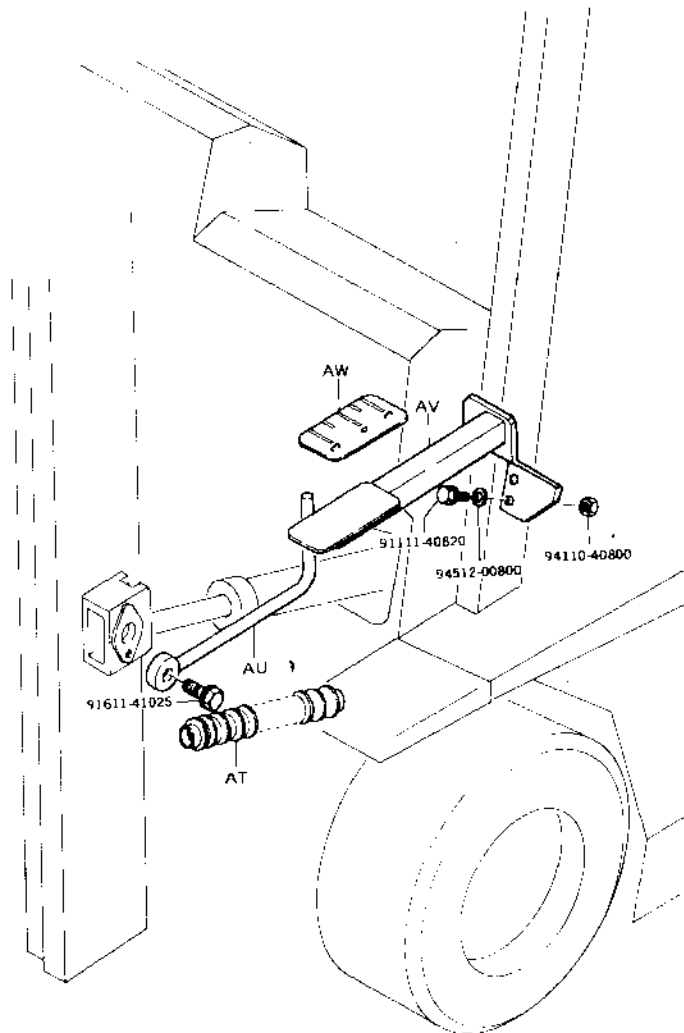

6511-013

PART NAME CODE	PART NAME	QTY
6511-01	CYLINDER ASSY, TILT -----	2
6511-01K	CYLINDER O/H KIT, TILT -----	2
6511-20	CYLINDER SUB-ASSY, TILT -----	2
6511-20A	BUSH, PIN (FOR CYLINDER) -----	2
6511-21	ROD SUB-ASSY, TILT CYLINDER PISTON -----	2
6511-21B	NUT, CASTLE -----	2
6511-30	GUIDE SUB-ASSY, TILT CYLINDER ROD -----	2
6511-31	PIN SUB-ASSY, TILT CYLINDER -----	2
6511-32	PIN SUB-ASSY, TILT CYLINDER, RR -----	2
6511-40	PISTON, TILT CYLINDER -----	2
6511-41	COVER, TILT CYLINDER -----	2
6511-42	SLEEVE, TILT CYLINDER ROD GUIDE -----	2
6511-44	JOINT, PISTON ROD -----	2
6511-50	SEAL, GREASE -----	2
6511-AA	RING, HOLE SNAP -----	2
6511-AB	SEAL, DUST -----	2
6511-AC	RING, BACK UP -----	2
6511-AD	RING, O -----	2
6511-AE	RING, BACK UP -----	2
6511-AF	PACKING, U -----	2
6511-AG	PLATE, STOPPER -----	2
6511-AH	RING, HOLE SNAP -----	2
6511-AI	RING, O -----	2
6511-AJ	PACKING, U -----	4
6511-AK	SHIM, TILT CONTROL -----	99
6511-AL	SPACER, TILT CONTROL -----	2
6511-AM	RING, O -----	4
6511-AN	COLLAR -----	4
6511-AU	SPACER, TILT CONTROL -----	2
6511-AT	BOOT SUB-ASSY -----	2
6511-AU	BAR SUB-ASSY, TILT GAUGE -----	1
6511-AV	BRACKET SUB-ASSY, TILT GAUGE -----	1
6511-AW	PLATE, TILT CYLINDER INDICATOR -----	1

(FSV) (6)

G210

FIG. 6701 OIL PUMP

6701

FSV

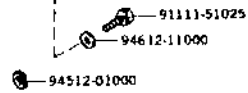
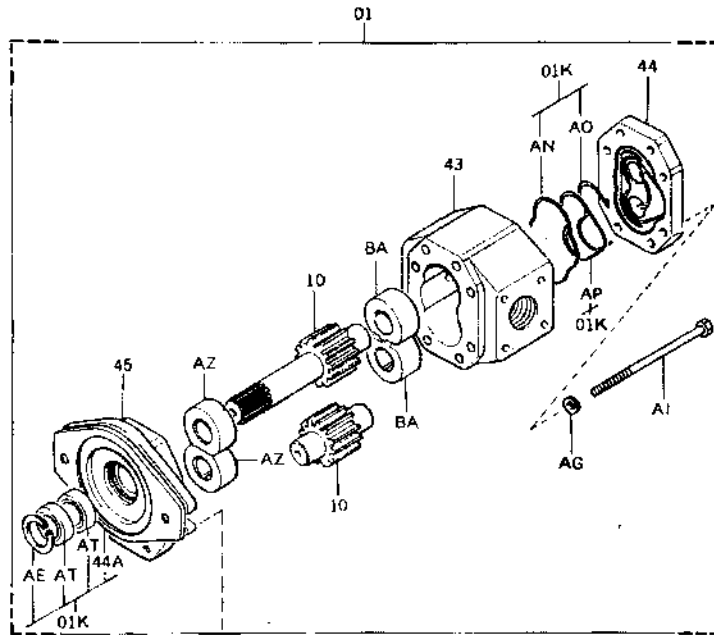

8701-018

PART NAME CODE	PART NAME	QTY
6701-01	PUMP ASSY, OIL -----	1
6701-01K	PUMP O/H KIT, OIL -----	1
6701-10	GEAR SET -----	1
6701-11	BUSH SET, NO.1 -----	2
6701-43	BODY -----	1
6701-44	FLANGE, MOUNTING -----	1
6701-45	COVER -----	1
6701-AA	SEAL, BUSHING -----	2
6701-AB	RING, BACKING, RH -----	2
6701-AC	RING, BACKING, LH -----	2
6701-AD	SEAL, OIL -----	1
6701-AE	RING, SNAP -----	1
6701-AF	BOLT -----	4
6701-AG	WASHER, SPRING -----	4
6701-AH	SEAL, BODY -----	2
6701-AI	BOLT -----	2

(FSV) (7)

G210

FIG. 6705 OIL CONTROL VALVE

6705

FSV

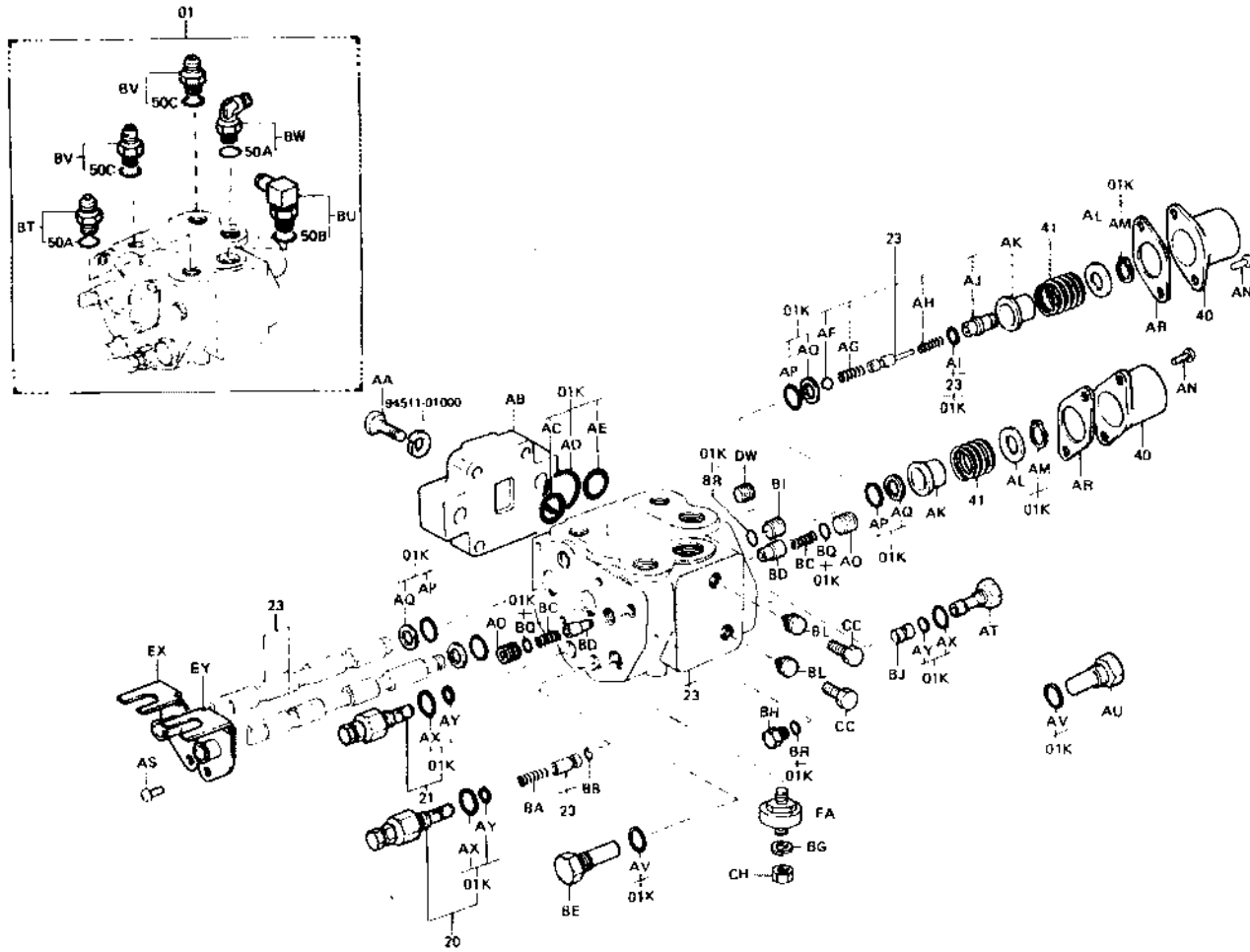

N°05 056

FIG. 6705 OIL CONTROL VALVE

6705

FSV (3-WAY, UL-EE)

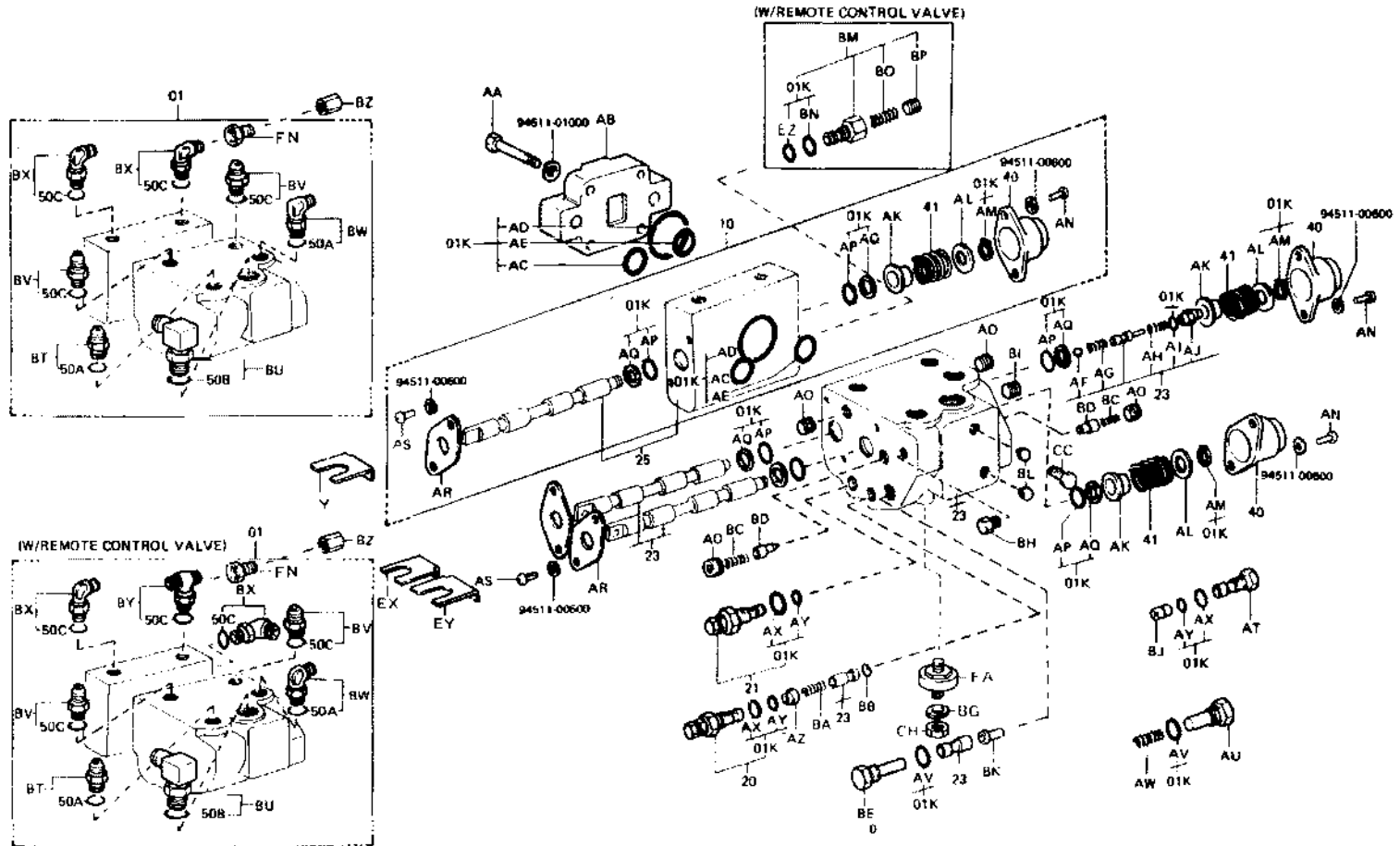

FIG. 6705 OIL CONTROL VALVE

6705

FSV (3-WAY)

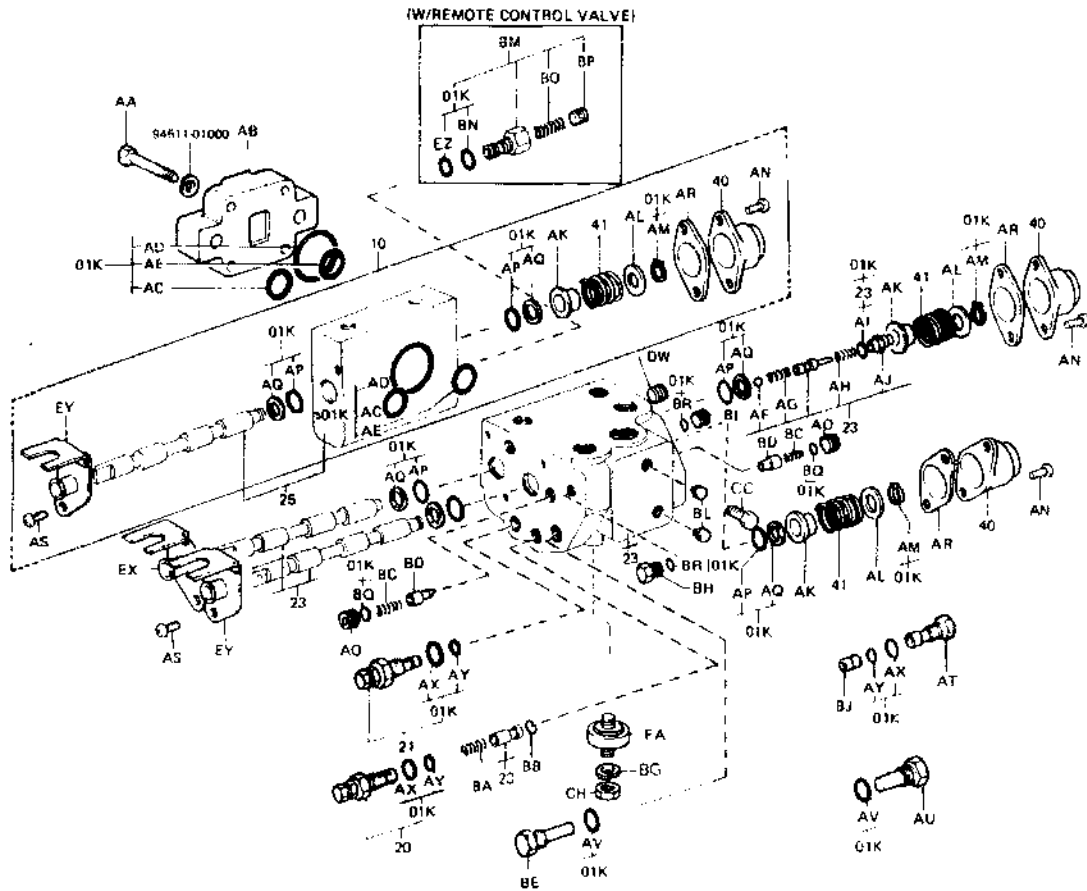
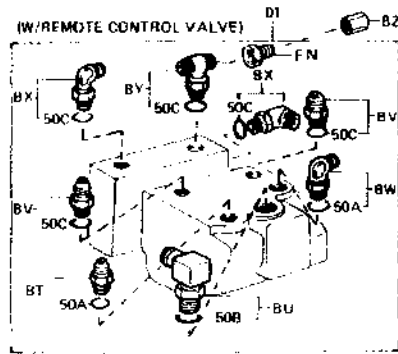
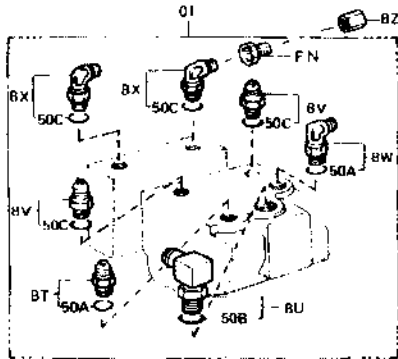
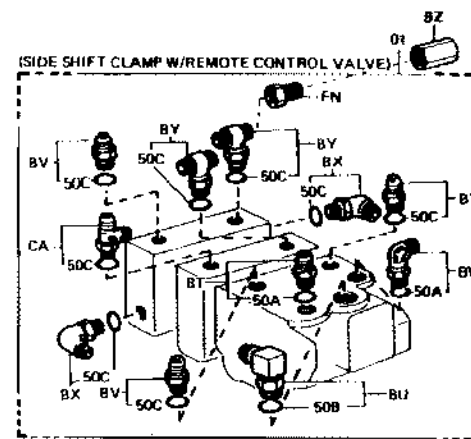
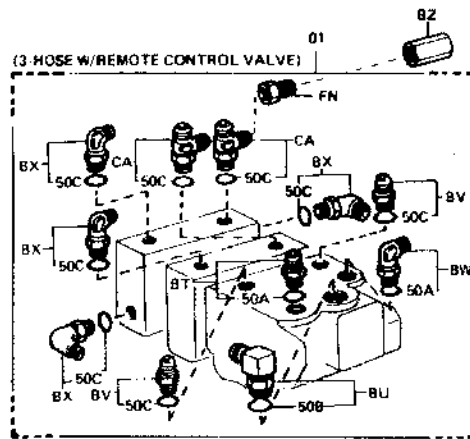
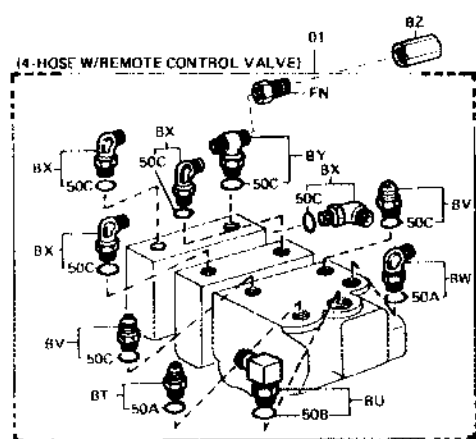
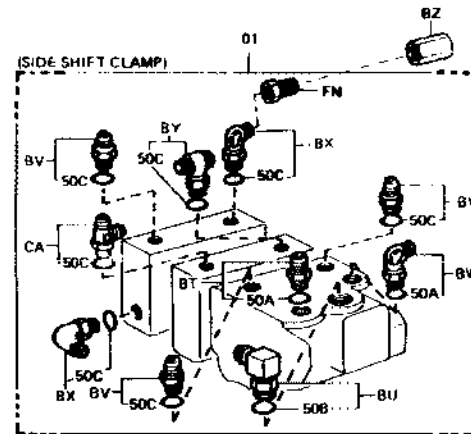
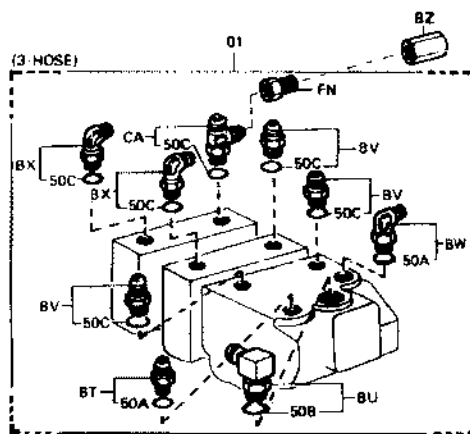
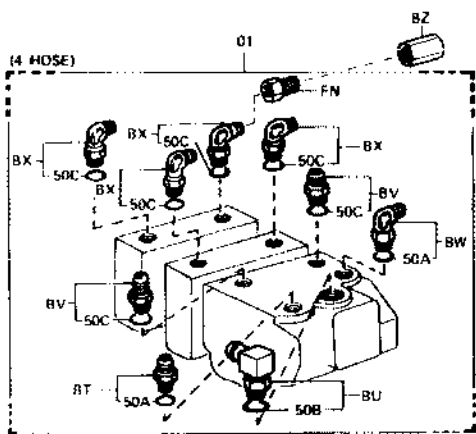

FIG. 6705 OH CONTROL VALVE

6705

FSV (4-WAY)



6705 05A



FIG. 6705 OIL CONTROL VALVE

6705

FSV (4-WAY..UL-EE)

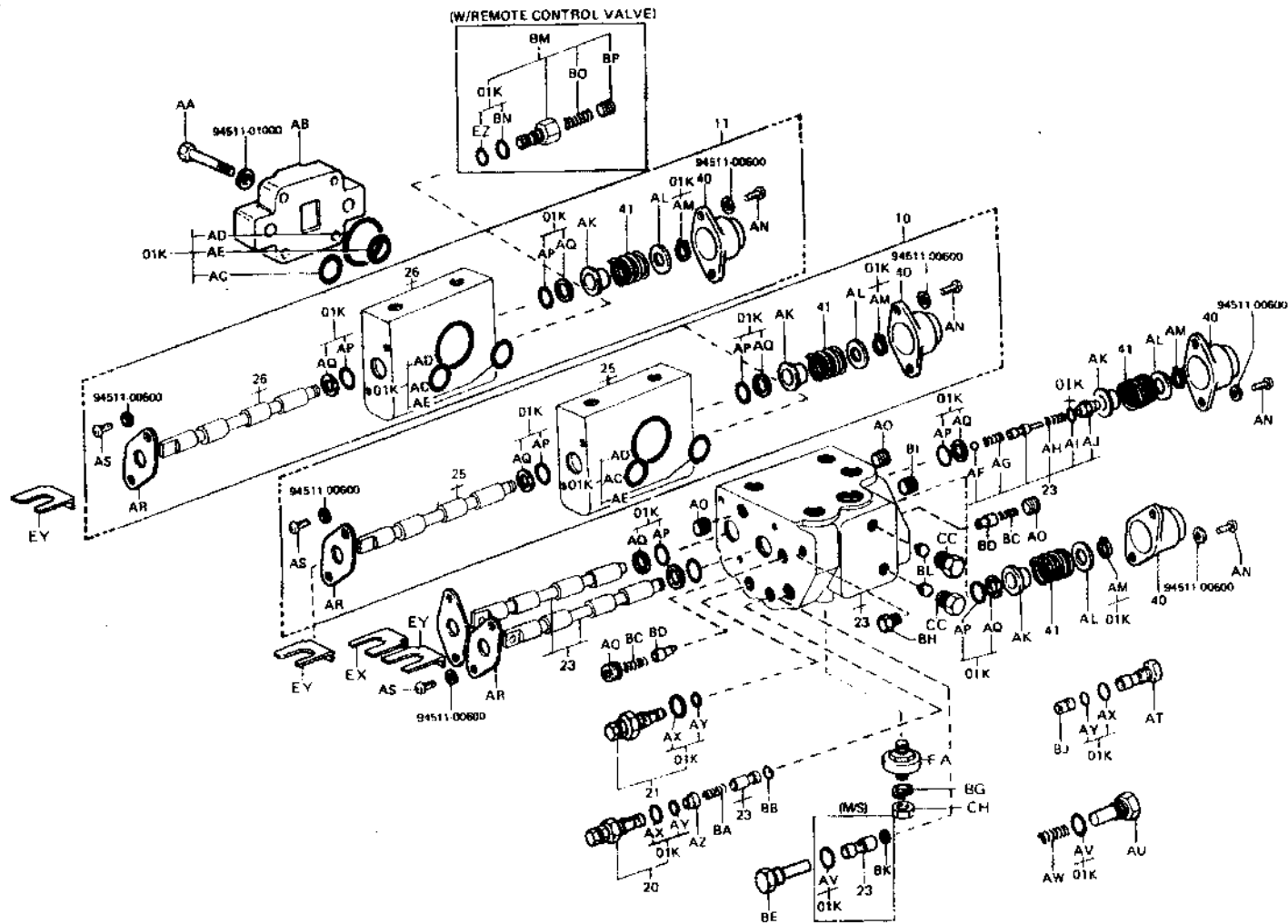
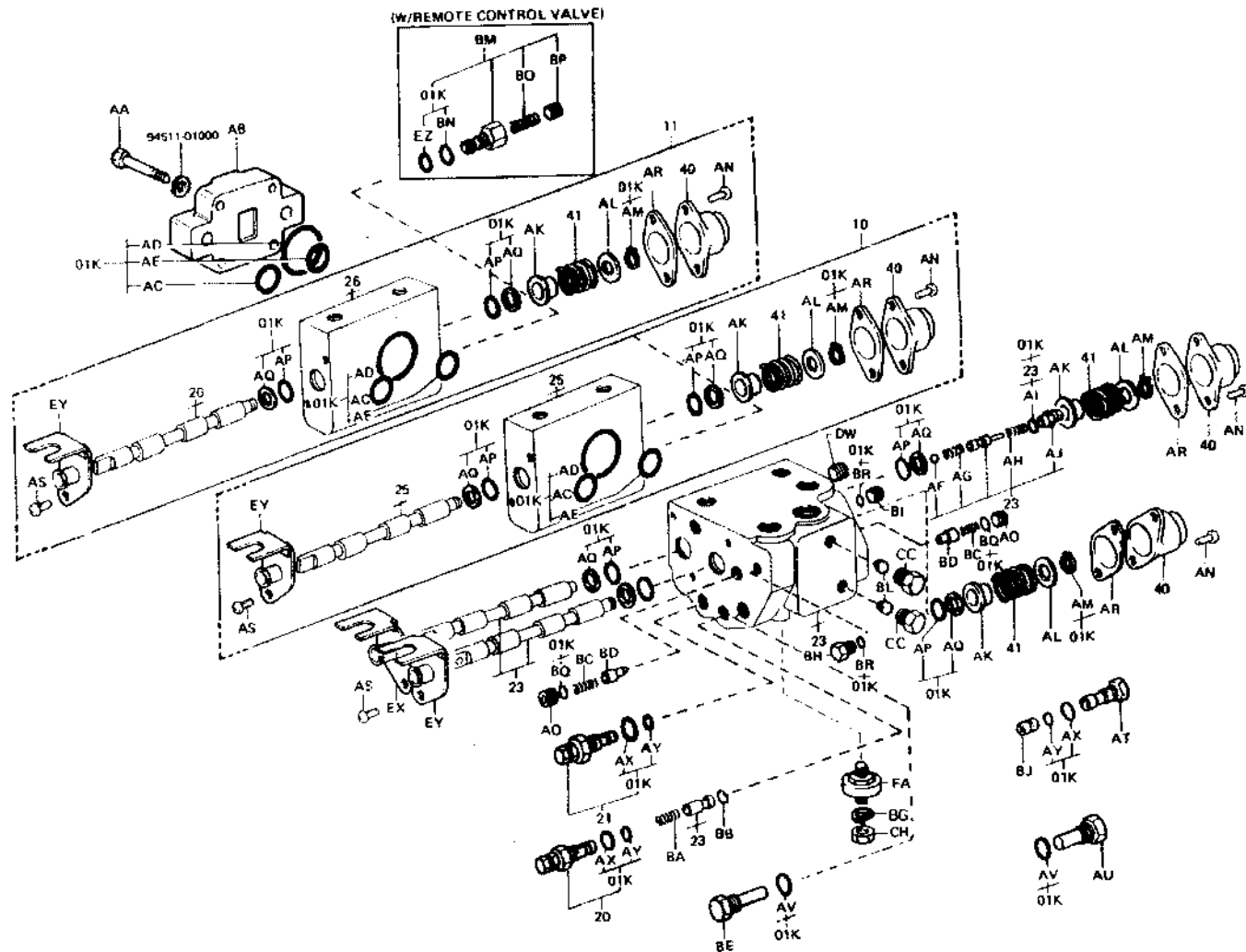

FIG. 6705 OIL CONTROL VALVE

6705

FSV (4-WAY)



6705

PART NAME CODE	PART NAME	QTY
6705-01	VALVE ASSY, OIL CONTROL -----	1
6705-01K	VALVE O/H KIT, OIL CONTROL -----	1
6705-10	VALVE ASSY, PLUNGER SECTION, NO.1 -----	1
6705-11	VALVE ASSY, PLUNGER SECTION, NO.2 -----	1
6705-20	VALVE SET, PILOT RELIEF, NO.1 -----	1
6705-21	VALVE SET, PILOT RELIEF, NO.2 -----	1
6705-23	HOUSING & SPOOL SET, NO.1 -----	1
6705-25	HOUSING & SPOOL SET, ATTACHMENT, NO.1 -----	1
6705-26	HOUSING & SPOOL SET, ATTACHMENT, NO.2 -----	1
6705-40	COVER, SPRING -----	2
6705-41	SPRING, COMPRESSION (FOR SPOOL RETURN) -----	2
6705-50A	RING, O, NO.1 (FOR VALVE FITTING) -----	2
6705-50B	RING, O, NO.2 (FOR VALVE FITTING) -----	1
6705-50C	RING, O, NO.3 (FOR VALVE FITTING) -----	2
6705-AA	BDLT -----	4
6705-AB	HOUSING, OUTLET -----	1
6705-AC	RING, O -----	1
6705-AD	RING, O -----	1
6705-AE	RING, O -----	1
6705-AF	BALL, STEEL -----	1
6705-AG	SPRING -----	1
6705-AH	SPRING, COMPRESSION -----	1
6705-AI	RING, O -----	1
6705-AJ	STOPPER -----	1
6705-AK	HOLDER, SPRING -----	2
6705-AL	WASHER, PLATE -----	2
6705-AM	RING, SHAFT SNAP -----	2
6705-AN	SCREW -----	4
6705-AO	PLUG -----	2
6705-AP	RING, O -----	4
6705-AQ	RING, BACK UP -----	4
6705-AR	HOLDER, SEAL -----	2
6705-AS	SCREW -----	4
6705-AT	STOPPER -----	1
6705-AU	STOPPER -----	1
6705-AV	RING, O -----	2
6705-AX	RING, O -----	3
6705-AY	RING, O -----	3
6705-BA	SPRING, COMPRESSION -----	1
6705-BB	WIRE, ORIFICE TURNING -----	1
6705-BC	SPRING, COMPRESSION -----	2
6705-BD	PLUNGER, CHECK -----	2
6705-BE	STOPPER -----	1
6705-BG	WASHER -----	4
6705-BH	PLUG -----	1
6705-BI	PLUG -----	1
6705-BJ	SEAT, VALVE -----	1
6705-BL	SEAT, INSERT -----	2
6705-BM	VALVE SUB-ASSY, RELIEF -----	1
6705-BN	RING, O -----	1
6705-BO	SPRING -----	1
6705-BP	STOPPER -----	1
6705-BQ	RING, O -----	2

(FSV) (8) G210

PART NAME CODE	PART NAME	QTY
6705-BR	RING, O -----	2
6705-BT	FITTING -----	1
6705-BU	FITTING -----	1
6705-BV	FITTING -----	2
6705-BW	FITTING -----	1
6705-BX	FITTING -----	2
6705-BY	FITTING -----	1
6705-BZ	PLUG -----	2
6705-CA	FITTING -----	1
6705-CC	PLUG -----	2
6705-CH	NUT -----	4
6705-CW	PLUG -----	1
6705-EX	BRACKET SUB-ASSY, TILT -----	1
6705-EY	BRACKET SUB-ASSY, LIFT -----	1
6705-EZ	RING, O -----	1
6705-FA	INSULATOR -----	4
6705-FN	FITTING -----	2

(FSV) (9) G210

FIG. 6709 OIL CONTROL VALVE LINK

6709

FSV

FSV (3-WAY)

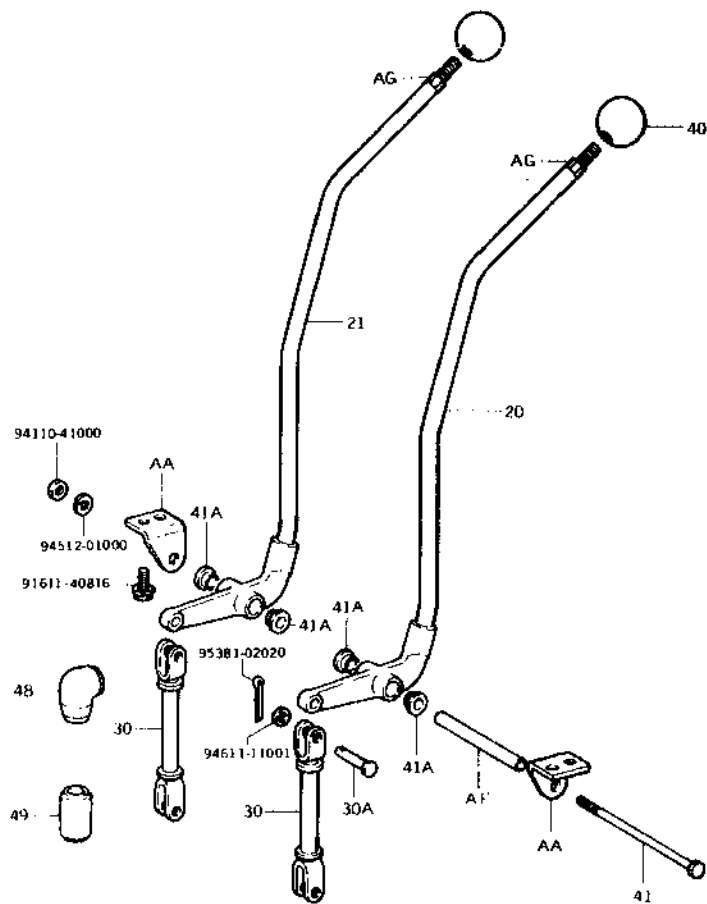

K709-016

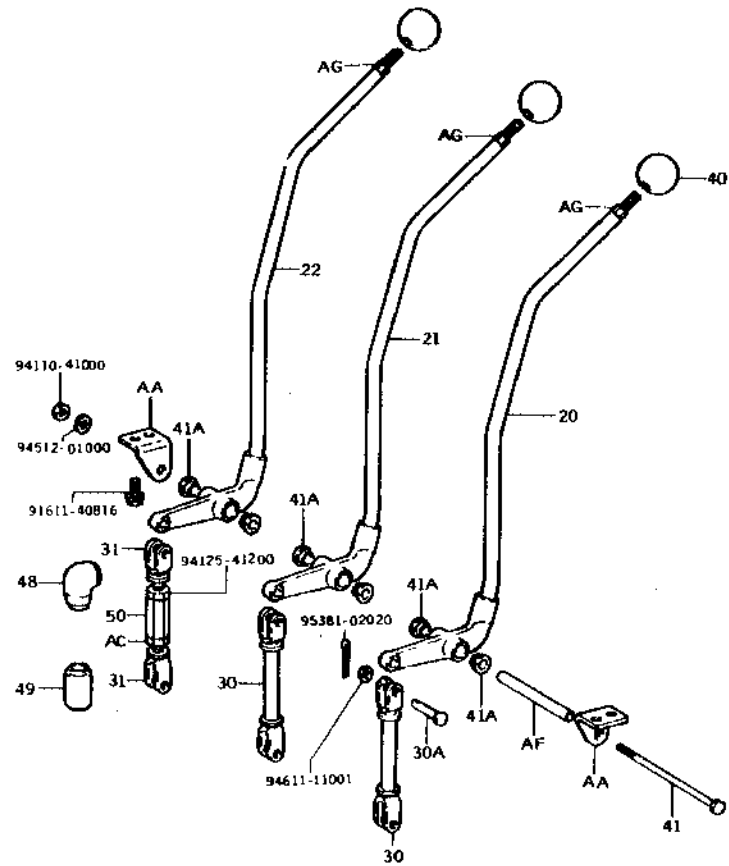

6709-017

FIG. 6709 OIL CONTROL VALVE LINK

6709

FSV (4-WAY)

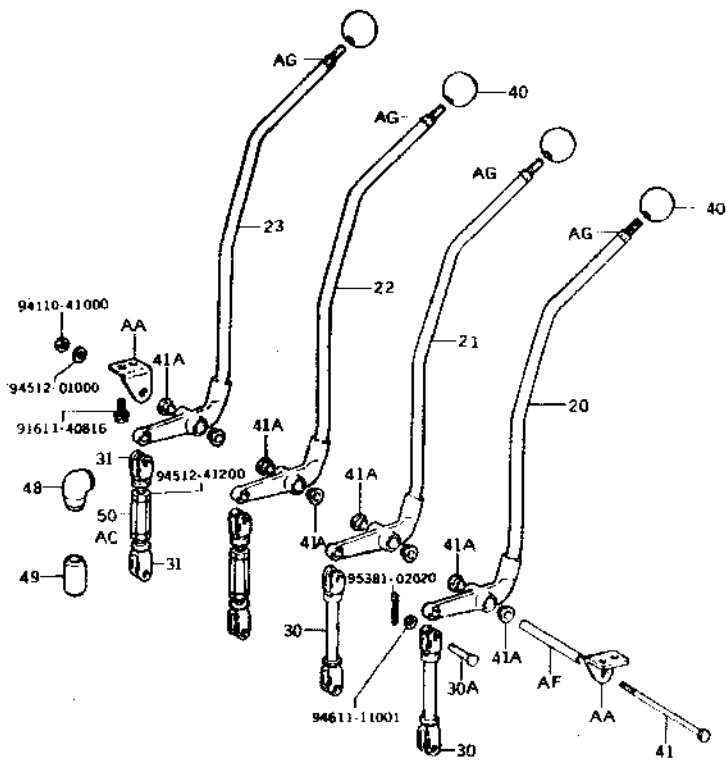

6709 018

PART NAME CODE	PART NAME	QTY
6709-20	LEVER SUB-ASSY, CONTROL VALVE, NO.1	1
6709-21	LEVER SUB-ASSY, CONTROL VALVE, NO.2	1
6709-22	LEVER SUB-ASSY, CONTROL VALVE, NO.3	1
6709-23	LEVER SUB-ASSY, CONTROL VALVE, NO.4	1
6709-30	ROD SUB-ASSY, CONTROL VALVE LEVER, NO.1	2
6709-30A	PIN (FOR CONTROL VALVE LEVER ROD)	4
6709-31	ROD SUB-ASSY, CONTROL VALVE LEVER, NO.2	1
6709-40	KNOB, OIL CONTROL VALVE LEVER	2
6709-41	PIN, OIL CONTROL VALVE LEVER	1
6709-41A	BUSH (FOR LEVER PIN)	4
6709-48	BOOT, CONTROL VALVE LINK, NO.1	2
6709-49	BOOT, CONTROL VALVE LINK, NO.2	2
6709-50	TURNBUCKLE	1
6709-AA	BRACKET SUB-ASSY	1
6709-AC	NUT	1
6709-AF	SPACER	1
6709-AG	BOLT, STUD	2

(FSV) (10)

G210

FIG. 6802 MAST PIPING

6802

FSV

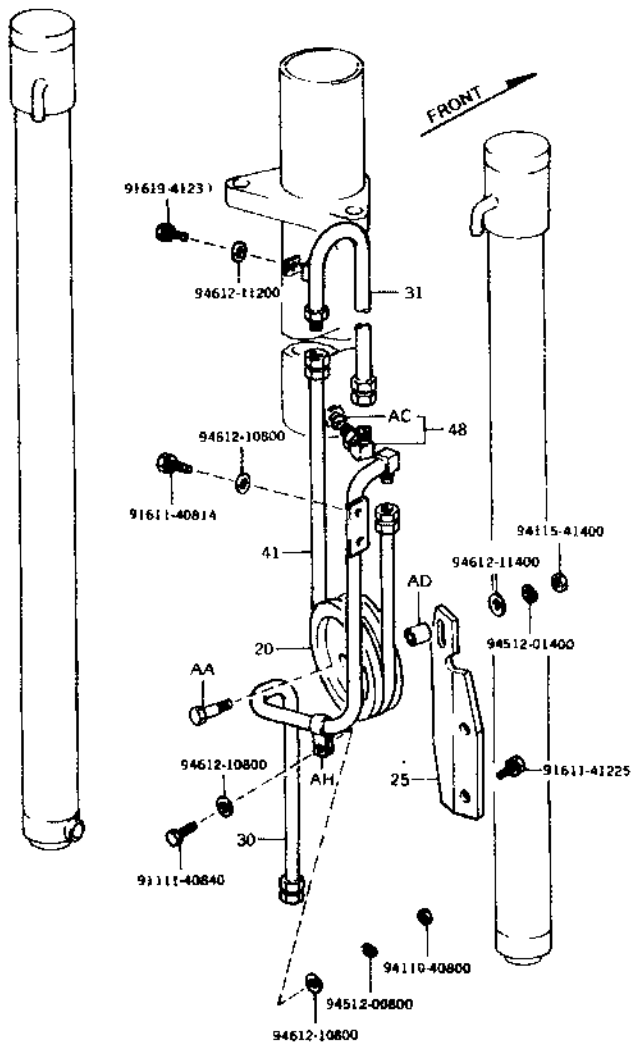

PART NAME CODE	PART NAME	QTY
6802-20	PULLEY SUB-ASSY, HOSE GUIDE, NO.1 -----	1
6802-25	BRACKET SUB-ASSY, GUIDE PULLEY -----	1
6802-30	PIPE SUB-ASSY, NO.1 (FRONT LIFT) -----	1
6802-31	PIPE SUB-ASSY, NO.2 (FRONT LIFT) -----	1
6802-41	HOSE, HIGH PRESSURE, NO.1 (FRONT LIFT) -----	1
6802-48	FITTING (FOR FRONT LIFT CYLINDER) -----	1
6802-AA	PIN, HOSE GUIDE PULLEY -----	1
6802-AC	RING, O -----	1
6802-AD	COLLAR -----	1
6802-AH	CLAMP -----	1

FIG. 6101 MAST

6101

FV

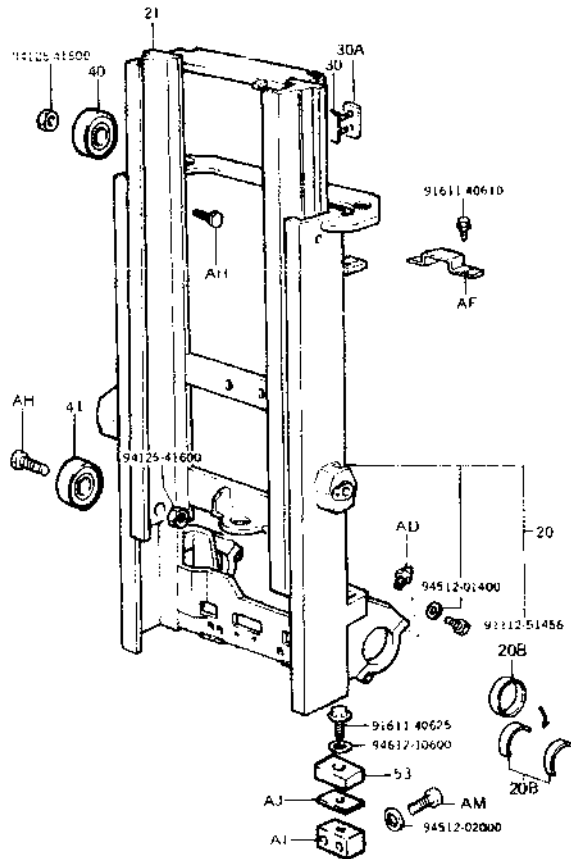

PART NAME CODE	PART NAME	QTY
6101-20	MAST SUB-ASSY, OUTER -----	1
6101-20B	BUSH, MAST SUPPORT -----	1
6101-21	MAST SUB-ASSY, INNER -----	1
6101-30	STRIP SUB-ASSY, OUTER MAST -----	2
6101-30A	SHIM, OUTER MAST STRIP -----	99
6101-40	ROLLER, LIFT (FOR OUTER MAST) -----	2
6101-41	ROLLER, LIFT (FOR INNER MAST) -----	2
6101-53	CUSHION, MAST (FOR INNER MAST) -----	2
6101-AD	FITTING, GREASE -----	2
6101-AF	COVER, ROLLER -----	2
6101-AH	BOLT -----	4
6101-AI	STOPPER -----	2
6101-AJ	SHIM, STOPPER -----	6
6101-AM	BOLT -----	4

6101-082 A

(FV) (1)

G210

FIG. 6301 LIFT BRACKET & FORK

6301

FV

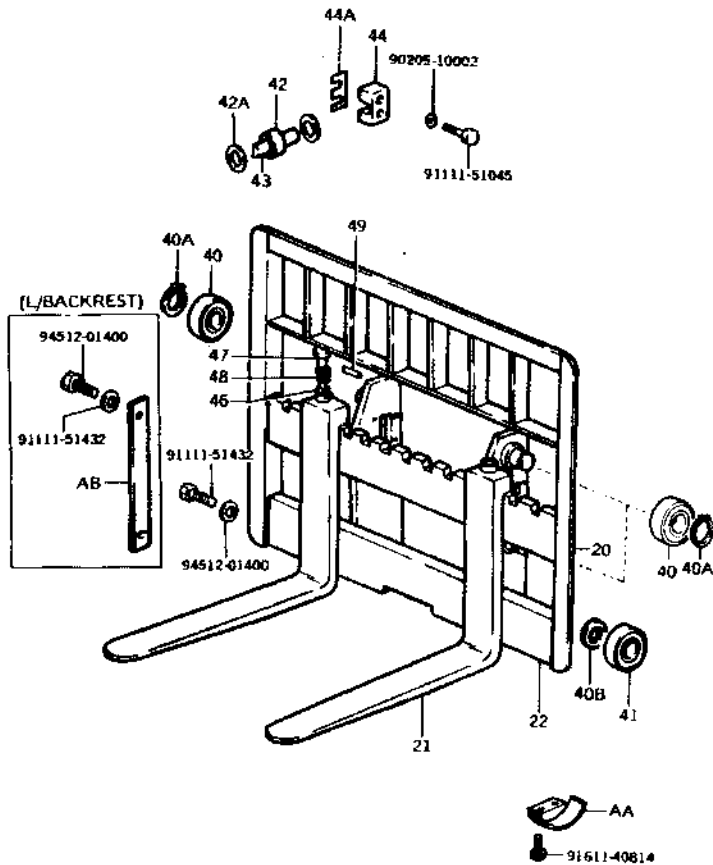

6301-022

PART NAME CODE	PART NAME	QTY
6301-20	BACKREST SUB-ASSY -----	1
6301-21	FORK SUB-ASSY -----	2
6301-22	BRACKET SUB-ASSY, LIFT -----	1
6301-40	ROLLER, LIFT (UPPER, LOWER) -----	4
6301-40A	RING, SHAFT SNAP (UPPER, LOWER) -----	4
6301-40B	SHIM, LIFT ROLLER -----	99
6301-41	ROLLER, LIFT (CENTER) -----	2
6301-42	ROLLER, SIDE -----	2
6301-42A	SHIM (FOR SIDE ROLLER) -----	4
6301-43	SHAFT, SIDE ROLLER -----	2
6301-44	HOLDER, SIDE ROLLER SHAFT -----	4
6301-44A	SHIM (FOR SHAFT HOLDER) -----	99
6301-46	PIN, FORK STOPPER -----	2
6301-47	KNOB, FORK STOPPER PIN -----	2
6301-48	SPRING, FORK STOPPER PIN -----	2
6301-49	PIN, SPRING (FOR FORK STOPPER PIN) -----	2
6301-AA	COVER, LIFT BRACKET ROLLER -----	4
6301-AB	PLATE, SIDE -----	2

(FV) (2)

G210

FIG. 6302 CHAIN & CHAIN WHEEL

6302

FV

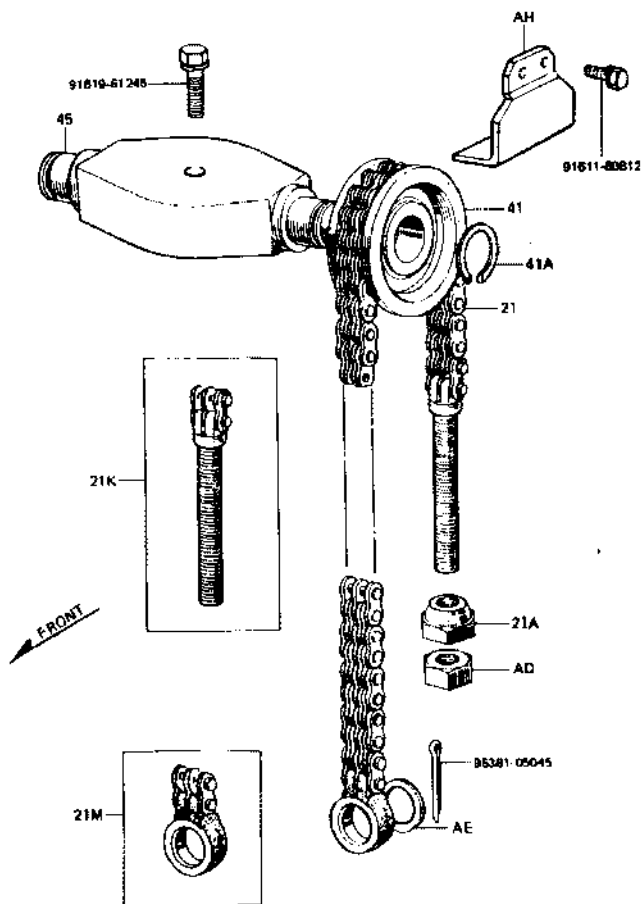

PART NAME CODE	PART NAME	QTY
6302-21	CHAIN SUB-ASSY (FRONT) -----	2
6302-21A	NUT, CHAIN ADJUST (FRONT) -----	2
6302-21K	BOLT KIT, CHAIN ANCHOR, NO.1 (FRONT) -----	2
6302-21M	BOLT KIT, CHAIN EYE (FRONT) -----	2
6302-41	WHEEL, CHAIN (FRONT) -----	2
6302-41A	RING, SHAFT SNAP (FOR FRONT CHAIN WHEEL) ---	2
6302-45	SUPPORT, CHAIN WHEEL -----	1
6302-AD	NUT, HEXAGON -----	2
6302-AE	WASHER, CHAIN SPECIAL -----	2
6302-AH	COVER, CHAIN WHEEL -----	2

6302-017 A

(FV) (3)

G210

FIG. 8602 FRONT LIFT CYLINDER

6502

FV

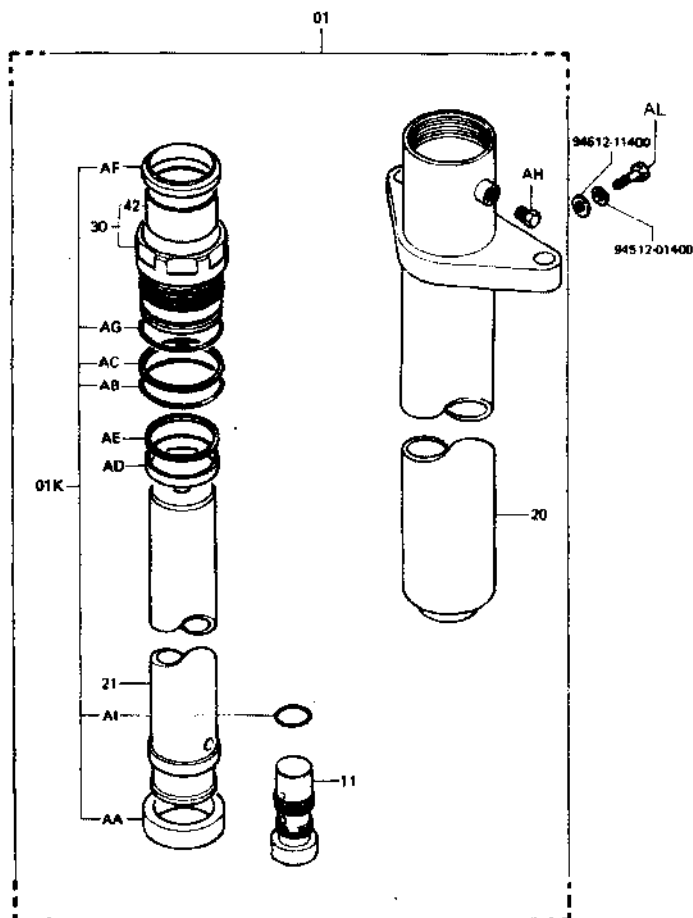

6502-001A

PART NAME CODE	PART NAME	QTY
6502-01	CYLINDER ASSY, LIFT	1
6502-01K	CYLINDER O/H KIT, LIFT	1
6502-11	VALVE ASSY, SAFETY DOWN	1
6502-20	CYLINDER SUB-ASSY, LIFT	1
6502-21	ROD SUB-ASSY, LIFT CYLINDER	1
6502-30	GUIDE SUB-ASSY, LIFT CYLINDER ROD	1
6502-42	SLEEVE, LIFT CYLINDER ROD GUIDE	1
6502-AA	BUSHING	1
6502-AB	RING, O	1
6502-AC	RING, BACK UP	1
6502-AD	PACKING, U	1
6502-AE	RING, BACK UP	1
6502-AF	SEAL, DUST	1
6502-AG	RING, O	1
6502-AH	PLUG	1
6502-AI	RING, O	1
6502-AL	BDLT	2

(FV) (4) G210

FIG. 8503 REAR LIFT CYLINDER

6503

FV

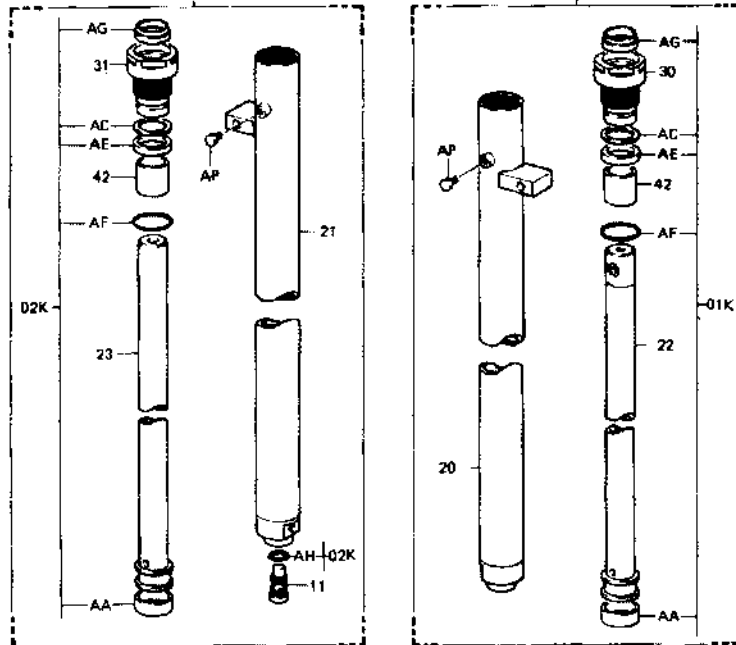
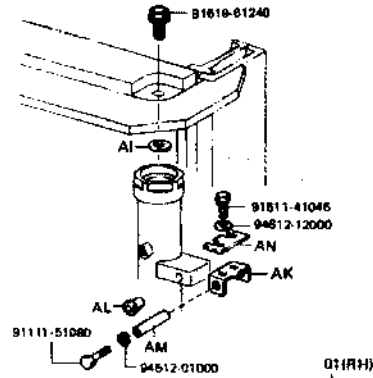

PART NAME CODE	PART NAME	QTY
6503-01	CYLINDER ASSY, LIFT, RH -----	1
6503-01K	CYLINDER O/H KIT, LIFT, RH -----	1
6503-02	CYLINDER ASSY, LIFT, LH -----	1
6503-02K	CYLINDER O/H KIT, LIFT, LH -----	1
6503-11	VALVE ASSY, SAFETY DOWN -----	1
6503-20	CYLINDER SUB-ASSY, LIFT, RH -----	1
6503-21	CYLINDER SUB-ASSY, LIFT, LH -----	1
6503-22	ROD SUB-ASSY, LIFT CYLINDER, RH -----	1
6503-23	ROD SUB-ASSY, LIFT CYLINDER, LH -----	1
6503-30	GUIDE SUB-ASSY, LIFT CYLINDER ROD, RH -----	1
6503-31	GUIDE SUB-ASSY, LIFT CYLINDER ROD, LH -----	1
6503-42	SLEEVE, LIFT CYLINDER ROD GUIDE -----	2
6503-AA	RING, WEAR -----	2
6503-AC	RING, BACK UP -----	2
6503-AD	RING, O -----	2
6503-AE	PACKING, U -----	2
6503-AG	SEAL, DUST -----	2
6503-AH	RING, O -----	1
6503-AI	SHIM -----	2- 3
6503-AK	BRACKET SUB-ASSY, LIFT CYLINDER -----	2
6503-AL	BUSHING -----	4
6503-AM	SPACER -----	2
6503-AN	SHIM -----	99
6503-AP	PLUG -----	2

(FV) (5)

6210

FIG. 6511 TILT CYLINDER

6511

FV

FV

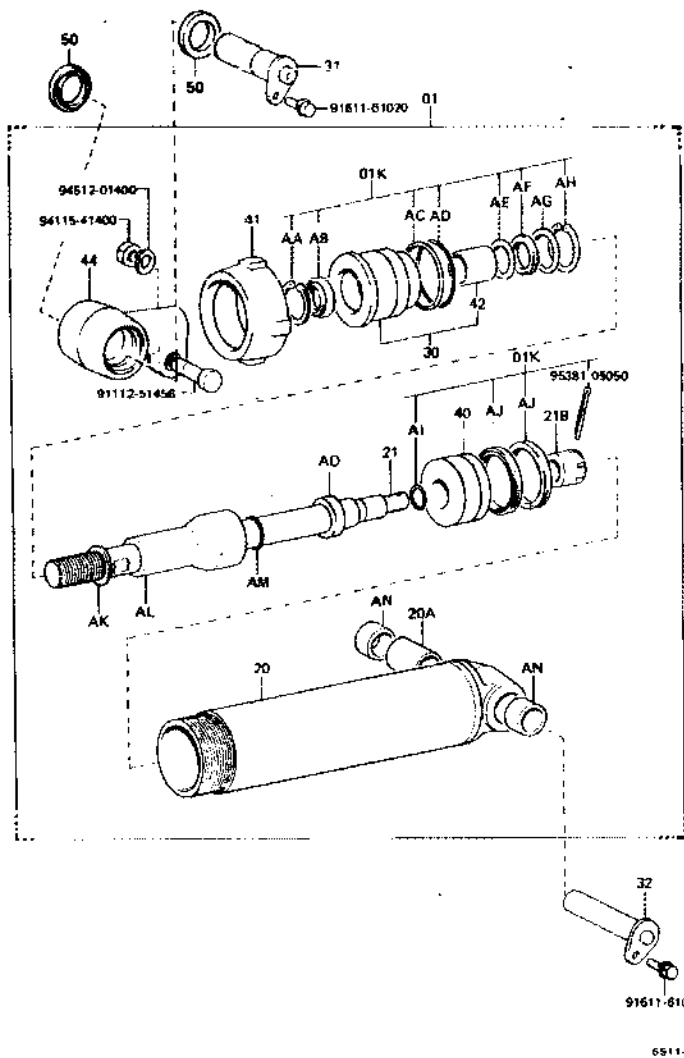

テイルト角度表
TABLE OF TILT RANGE

生産期間 PRODD DATE	型式 MODELS	タイヤ TIRE	揚 高 LIFTING HEIGHT	備 考 DESCRIPTION	テイルト角 TILT RANGE
8009-	F, FV, M, SV, V	SINGLE	H2000-H4000		6D - 12D
8009-	F, FV, M, SV, V	DOUBLE	H2000-H4500		6D - 12D
8009-	F, FV, M, SV, V	SINGLE	H4500-H5000		6D - 6D
8009-	F, FV, M, SV, V	DOUBLE	H5000		6D - 6D
8009-	F, FV, M, SV, V		H2000	FRONT GLASS	8D - 10D
8009-	FSV, FS		H3700-H6500		8D - 6D
8009-	F, FV, M, SV, V	SINGLE	H2000-H4000	AUSTRALIA	3D - 12D
8009-	F, FV, M, SV, V	DOUBLE	H2000-H4500	AUSTRALIA	3D - 12D
8009-	F, FV, M, SV, V	SINGLE	H4500-H5000	AUSTRALIA	3D - 8D
8009-	F, FV, M, SV, V	DOUBLE	H5000	AUSTRALIA	3D - 6D
8009-	F, FV, M, SV, V		H2000	FRONT GLASS AUSTRALIA	3D - 10D
8009-	FV, M, SV, V		H3700-H6500	AUSTRALIA	3D - 6D

6511-019



FIG. 6511 TILT CYLINDER

6511

FV

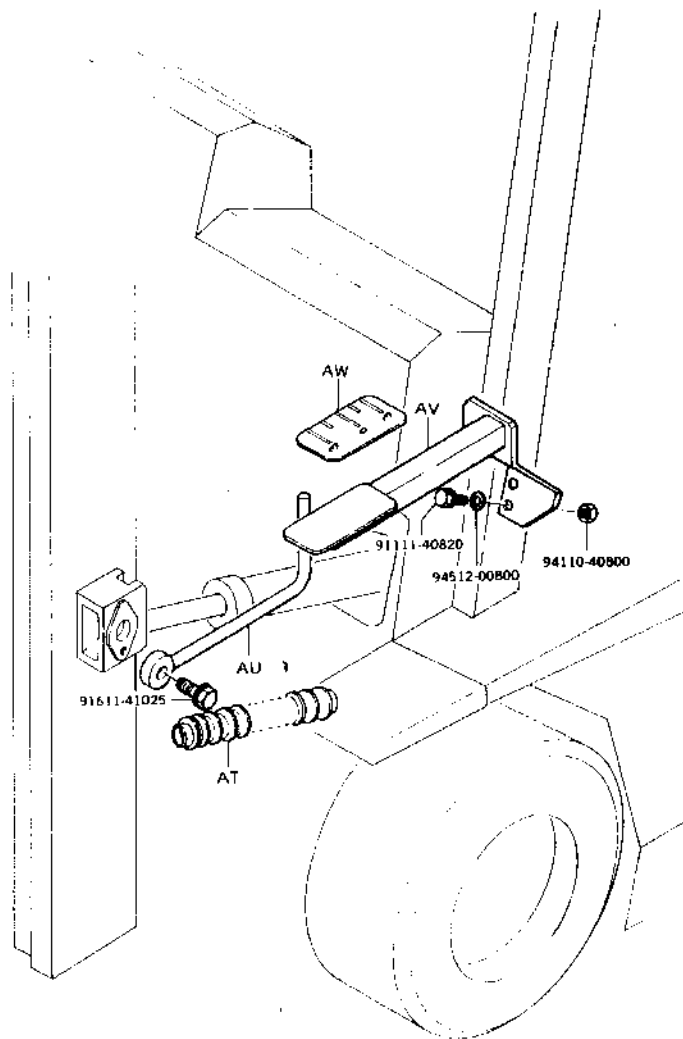

6511-013

PART NAME CODE	PART NAME	QTY
6511-01	CYLINDER ASSY, TILT -----	2
6511-01K	CYLINDER O/H KIT, TILT -----	2
6511-20	CYLINDER SUB-ASSY, TILT -----	2
6511-20A	BUSH, PIN (FOR CYLINDER) -----	2
6511-21	ROD SUB-ASSY, TILT CYLINDER PISTON -----	2
6511-21B	NUT, CASTLE -----	2
6511-30	GUIDE SUB-ASSY, TILT CYLINDER ROD -----	2
6511-31	PIN SUB-ASSY, TILT CYLINDER -----	2
6511-32	PIN SUB-ASSY, TILT CYLINDER, RR -----	2
6511-40	PISTON, TILT CYLINDER -----	2
6511-41	COVER, TILT CYLINDER -----	2
6511-42	SLEEVE, TILT CYLINDER ROD GUIDE -----	2
6511-44	JOINT, PISTON ROD -----	2
6511-50	SEAL, GREASE -----	2
6511-AA	RING, HOLE SNAP -----	2
6511-AB	SEAL, DUST -----	2
6511-AC	RING, BACK UP -----	2
6511-AD	RING, O -----	2
6511-AE	RING, BACK UP -----	2
6511-AF	PACKING, U -----	2
6511-AG	PLATE, STOPPER -----	2
6511-AH	RING, HOLE SNAP -----	2
6511-AI	RING, O -----	2
6511-AJ	PACKING, U -----	4
6511-AK	SHIM, TILT CONTROL -----	99
6511-AL	SPACER, TILT CONTROL -----	2
6511-AM	RING, O -----	4
6511-AN	COLLAR -----	4
6511-AD	SPACER, TILT CONTROL -----	2
6511-AT	BOOT SUB-ASSY -----	2
6511-AU	BAR SUB-ASSY, TILT GAUGE -----	1
6511-AV	BRACKET SUB-ASSY, TILT GAUGE -----	1
6511-AW	PLATE, TILT CYLINDER INDICATOR -----	1

(FV) (6)

G210

FIG. 6701 OIL PUMP

6701

FV

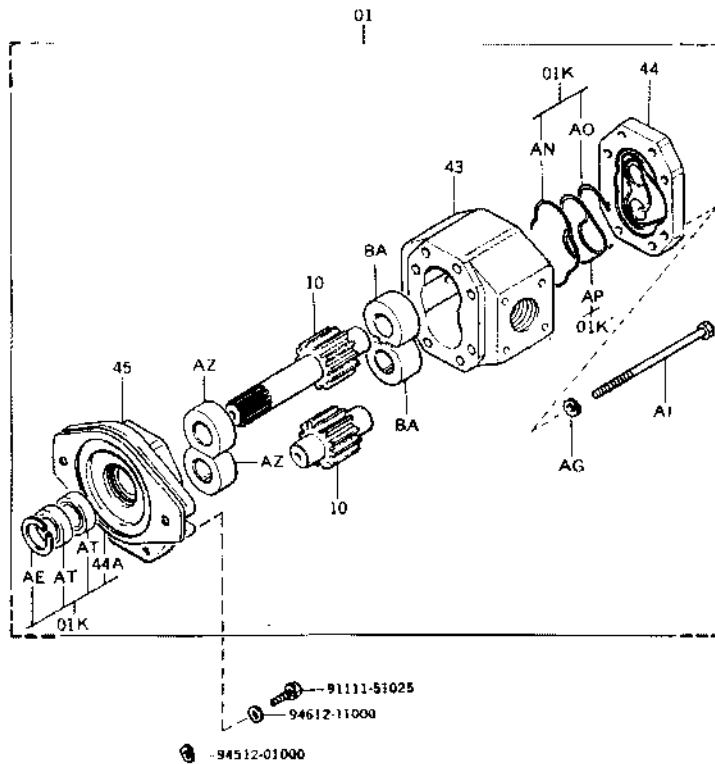

8701-01B

PART NAME CODE	PART NAME	QTY
6701-01	PUMP ASSY, OIL	1
6701-01K	PUMP O/H KIT, OIL	1
6701-10	GEAR SET	1
6701-11	BUSH SET, NO.1	2
6701-43	BODY	1
6701-44	FLANGE, MOUNTING	1
6701-45	COVER	1
6701-AA	SEAL, BUSHING	2
6701-AB	RING, BACKING, RH	2
6701-AC	RING, BACKING, LH	2
6701-AD	SEAL, DIL	1
6701-AE	RING, SNAP	1
6701-AF	BOLT	4
6701-AG	WASHER, SPRING	4
6701-AH	SEAL, BODY	2
6701-AI	BOLT	2

(FV) (7)

G210

FIG. 6705 OIL CONTROL VALVE

6705

FV

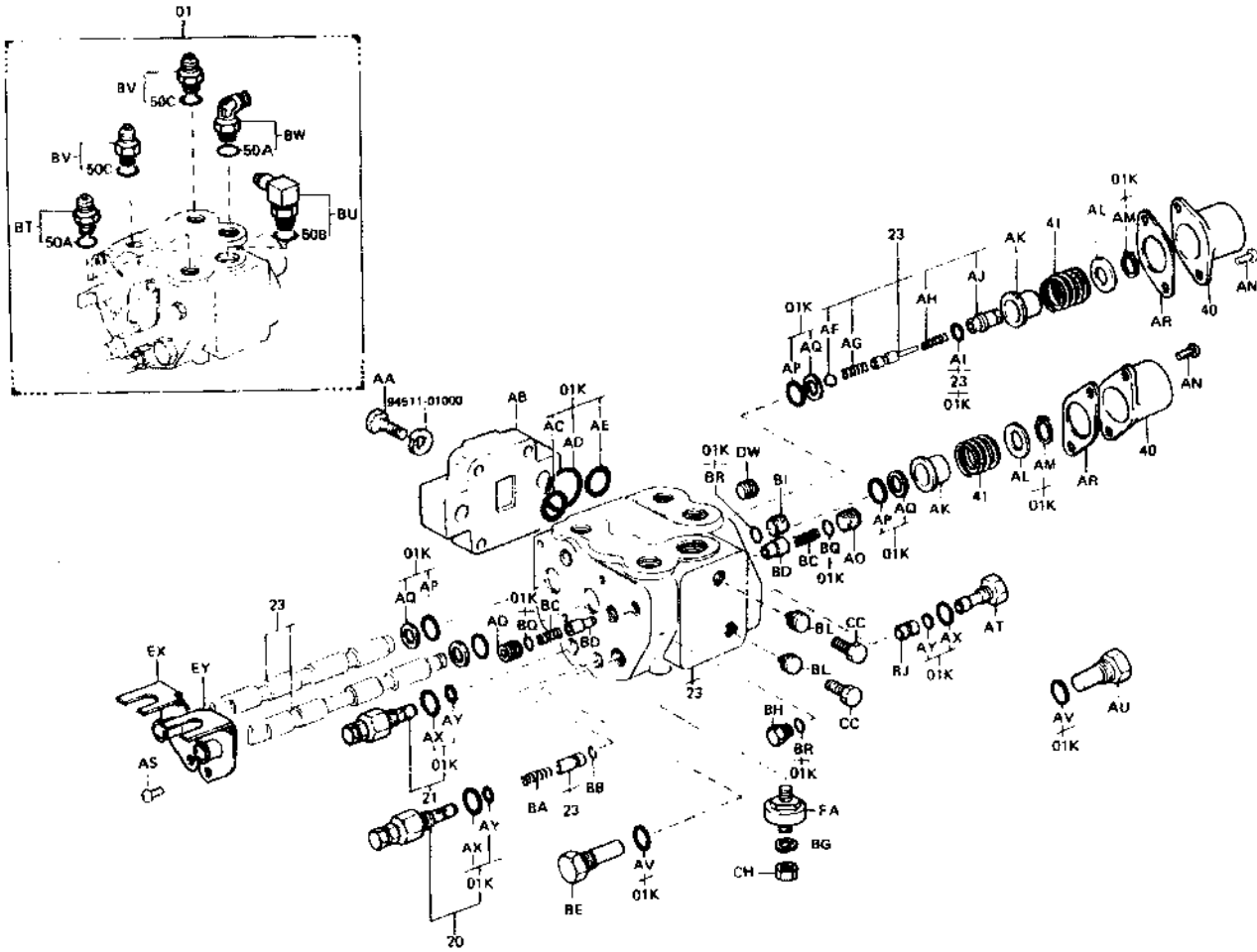

6705-056

FIG. 6705 OIL CONTROL VALVE

6705

FV (3-WAY..UL-EE)

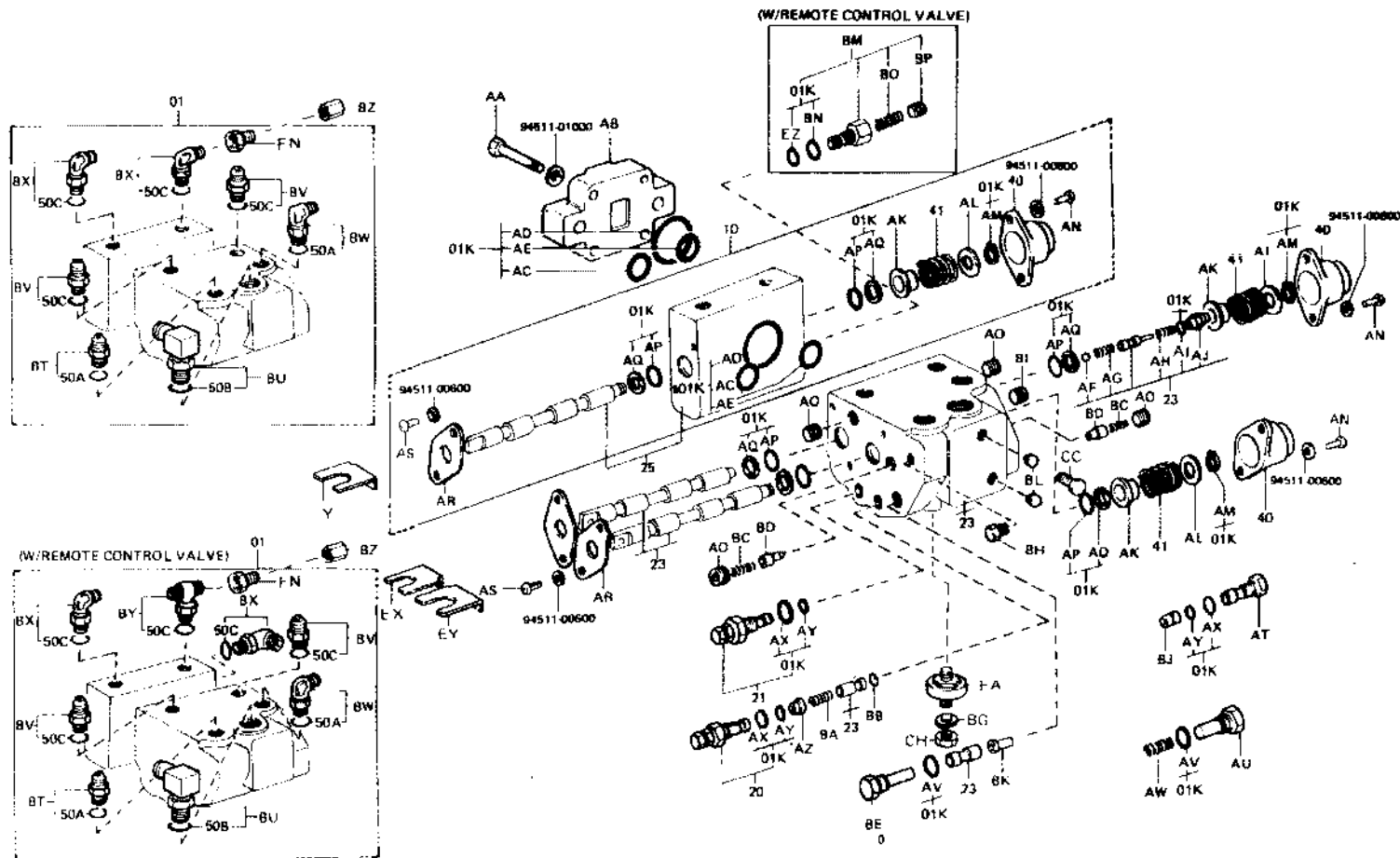
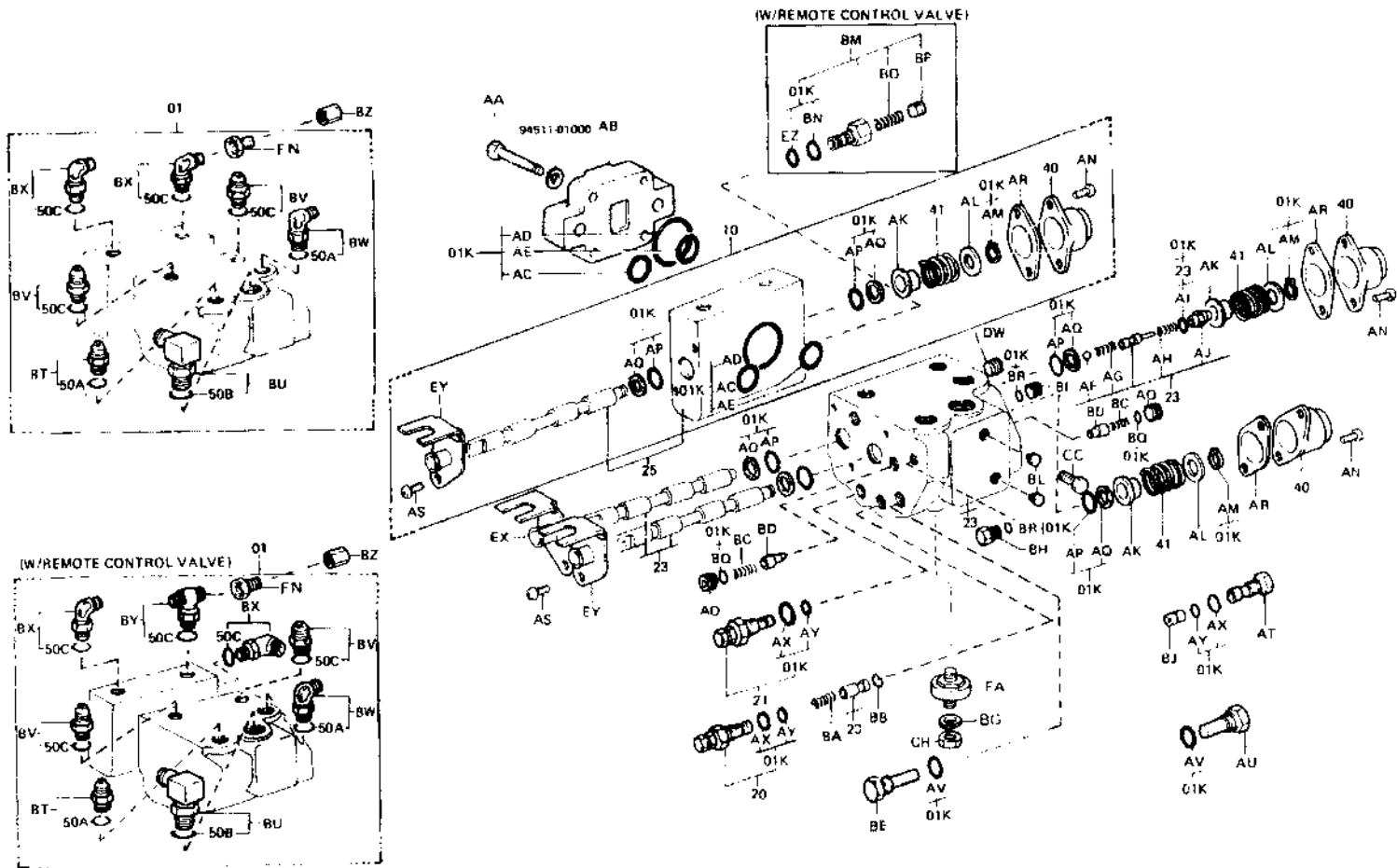

FIG. 6705 OIL CONTROL VALVE

6705

FV (3-WAY)



6705-057

FIG. 6705 OIL CONTROL VALVE

6705

FV (4-WAY)

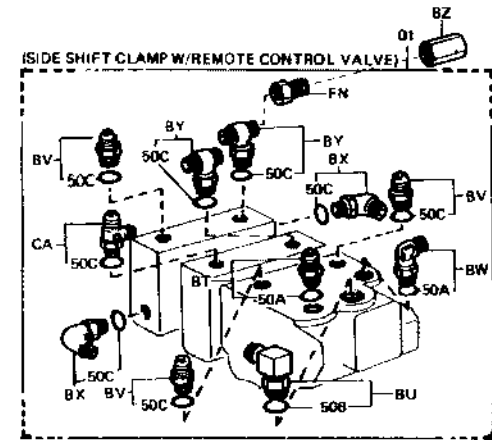
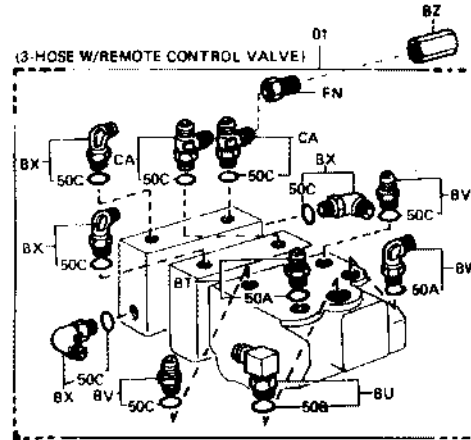
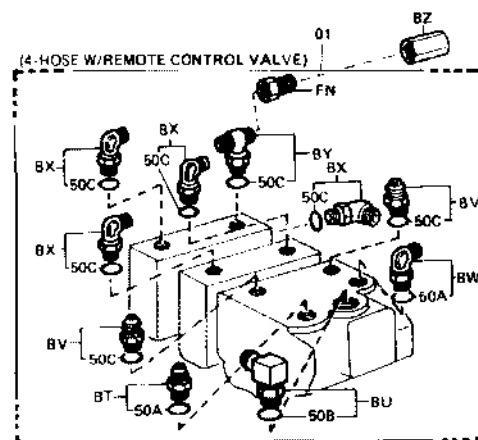
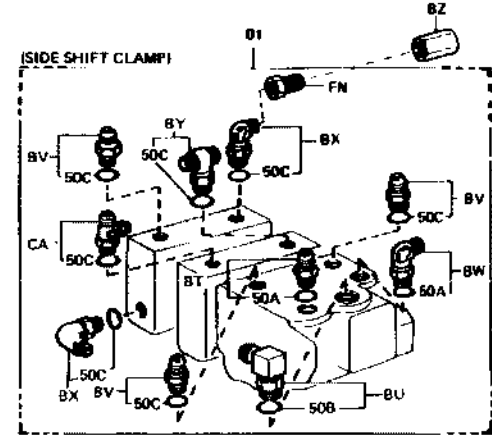
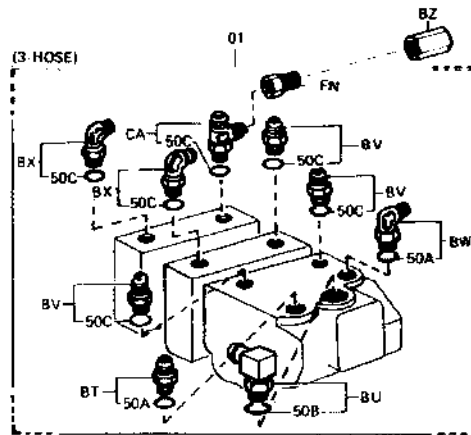
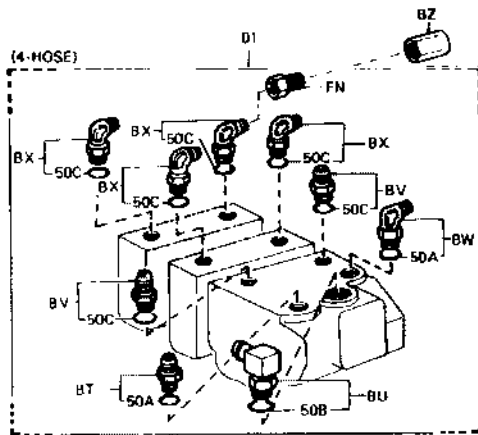

6708-056



FIG. 6705 OIL CONTROL VALVE

6705

FV (4-WAY..UL-EE)

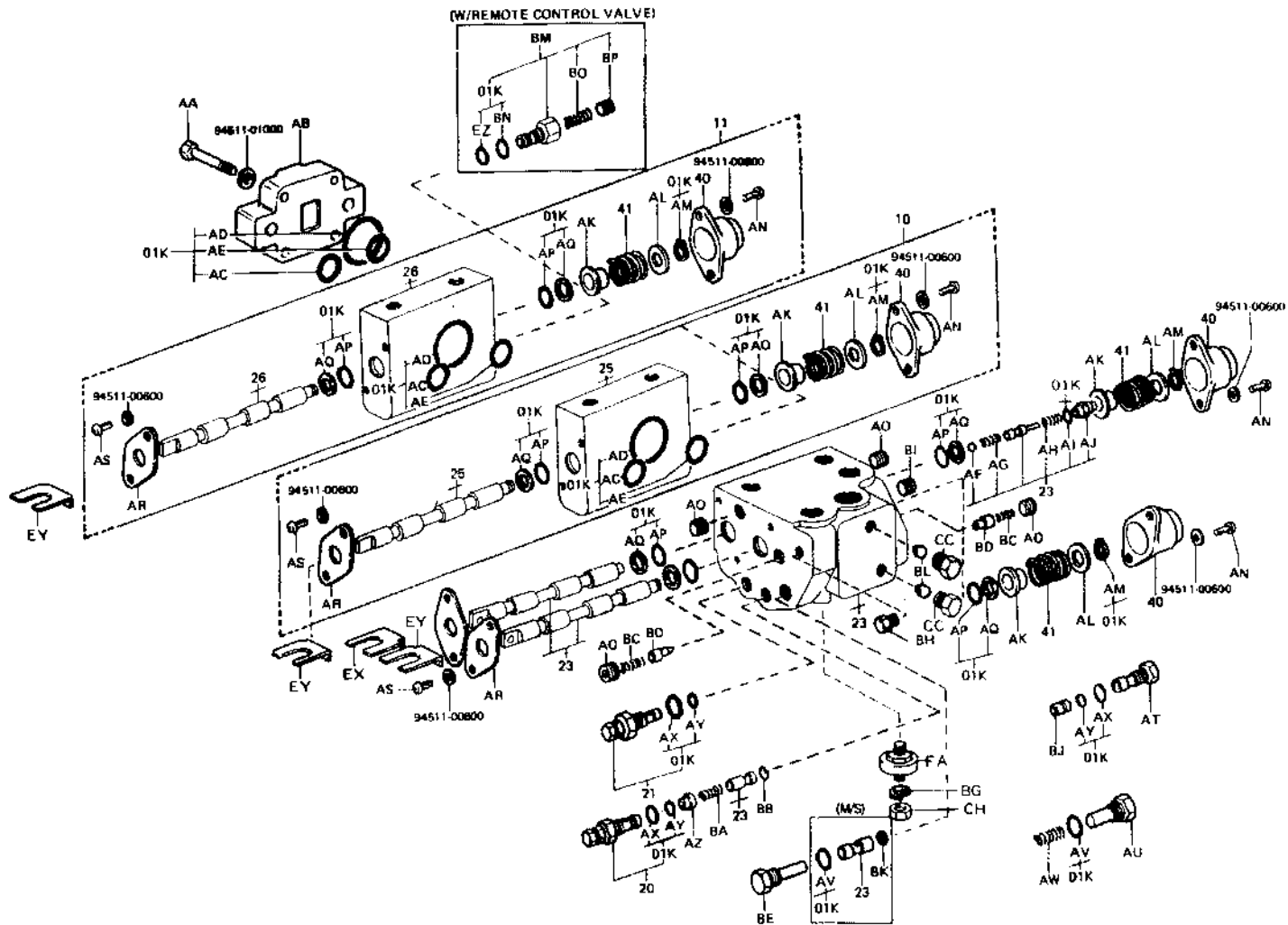
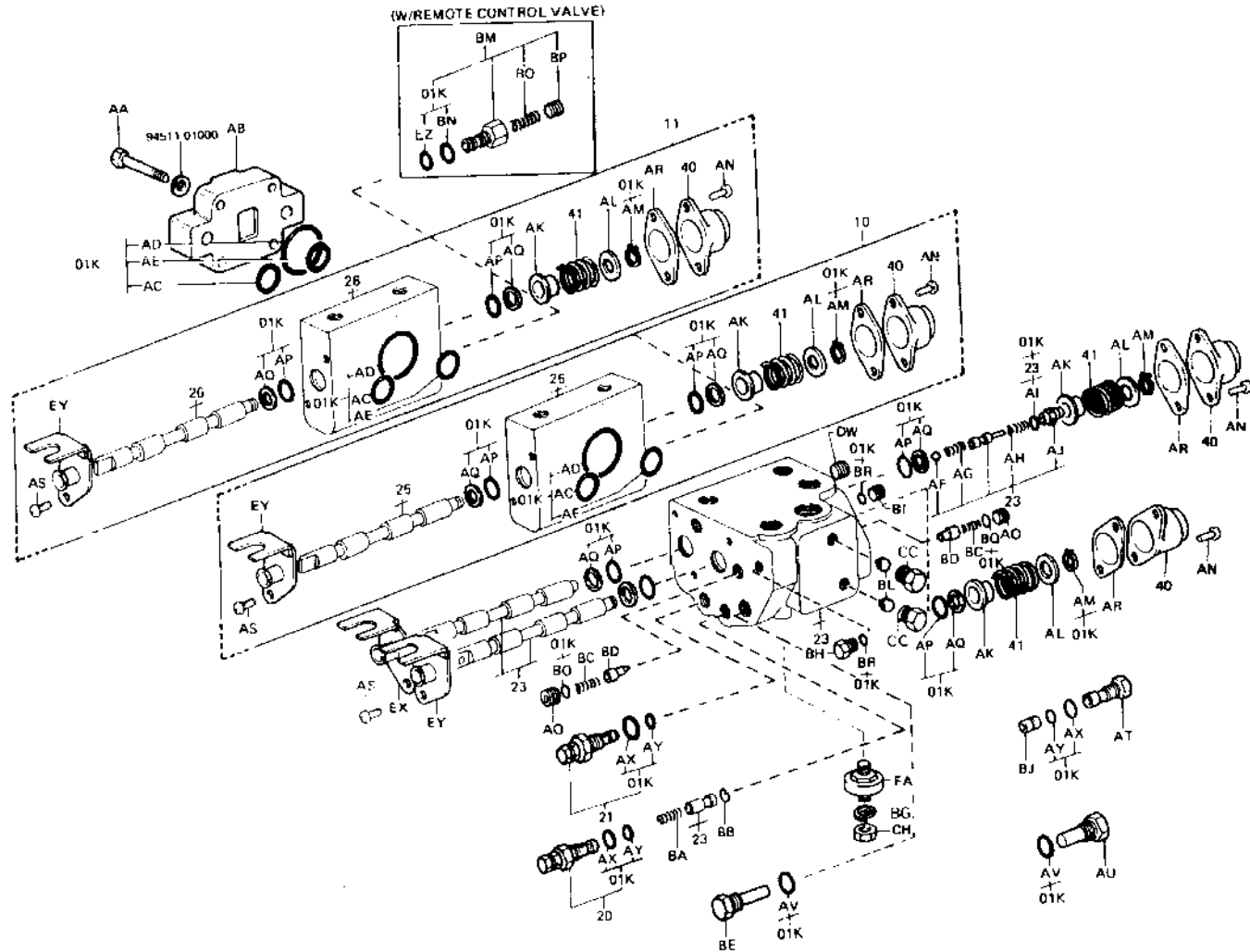

FIG. 6705 OIL CONTROL VALVE

6705

FV (4-WAY)



6705

PART NAME CODE	PART NAME	QTY
6705-01	VALVE ASSY, OIL CONTROL	1
6705-01K	VALVE G/H KIT, OIL CONTROL	1
6705-10	VALVE ASSY, PLUNGER SECTION, NO.1	1
6705-11	VALVE ASSY, PLUNGER SECTION, NO.2	1
6705-20	VALVE SET, PILOT RELIEF, NO.1	1
6705-21	VALVE SET, PILOT RELIEF, NO.2	1
6705-23	HOUSING & SPOOL SET, NO.1	1
6705-25	HOUSING & SPOOL SET, ATTACHMENT, NO.1	1
6705-26	HOUSING & SPOOL SET, ATTACHMENT, NO.2	1
6705-4D	COVER, SPRING	2
6705-4I	SPRING, COMPRESSION (FOR SPOOL RETURN)	2
6705-50A	RING, O, NO.1 (FOR VALVE FITTING)	2
6705-50B	RING, O, NO.2 (FOR VALVE FITTING)	1
6705-50C	RING, O, NO.3 (FOR VALVE FITTING)	2
6705-AA	BOLT	4
6705-AB	HOUSING, OUTLET	1
6705-AC	RING, O	1
6705-AD	RING, O	1
6705-AE	RING, O	1
6705-AF	BALL, STEEL	1
6705-AG	SPRING	1
6705-AH	SPRING, COMPRESSION	1
6705-AI	RING, O	1
6705-AJ	STOPPER	1
6705-AK	HOLDER, SPRING	2
6705-AL	WASHER, PLATE	2
6705-AM	RING, SHAFT SNAP	2
6705-AN	SCREW	4
6705-AO	PLUG	2
6705-AP	RING, O	4
6705-AQ	RING, BACK UP	4
6705-AR	HOLDER, SEAL	2
6705-AS	SCREW	4
6705-AT	STOPPER	1
6705-AU	STOPPER	1
6705-AV	RING, O	2
6705-AX	RING, O	3
6705-AY	RING, O	3
6705-BA	SPRING, COMPRESSION	1
6705-BB	WIRE, ORIFICE TURNING	1
6705-BC	SPRING, COMPRESSION	2
6705-BD	PLUNGER, CHECK	2
6705-BE	STOPPER	1
6705-BG	WASHER	4
6705-BH	PLUG	1
6705-BI	PLUG	1
6705-BJ	SEAT, VALVE	1
6705-BL	SEAT, INSERT	2
6705-BM	VALVE SUB-ASSY, RELIEF	1
6705-BN	RING, O	1
6705-BO	SPRING	1
6705-BP	STOPPER	1
6705-BQ	RING, O	2

(FV) (8) G210

PART NAME CODE	PART NAME	QTY
6705-BR	HING, O	2
6705-BT	FITTING	1
6705-BU	FITTING	1
6705-BV	FITTING	2
6705-BW	FITTING	1
6705-BX	FITTING	2
6705-BY	FITTING	1
6705-BZ	PLUG	2
6705-CA	FITTING	1
6705-CC	PLUG	2
6705-CH	NUT	4
6705-CW	PLUG	1
6705-EX	BRACKET SUB-ASSY, TILT	1
6705-EY	BRACKET SUB-ASSY, LIFT	1
6705-EZ	RING, O	1
6705-FA	INSULATOR	4
6705-FN	FITTING	2

(FV) (9) G210

FIG. 6709 OIL CONTROL VALVE LINK

6709

FV

FV (3-WAY)

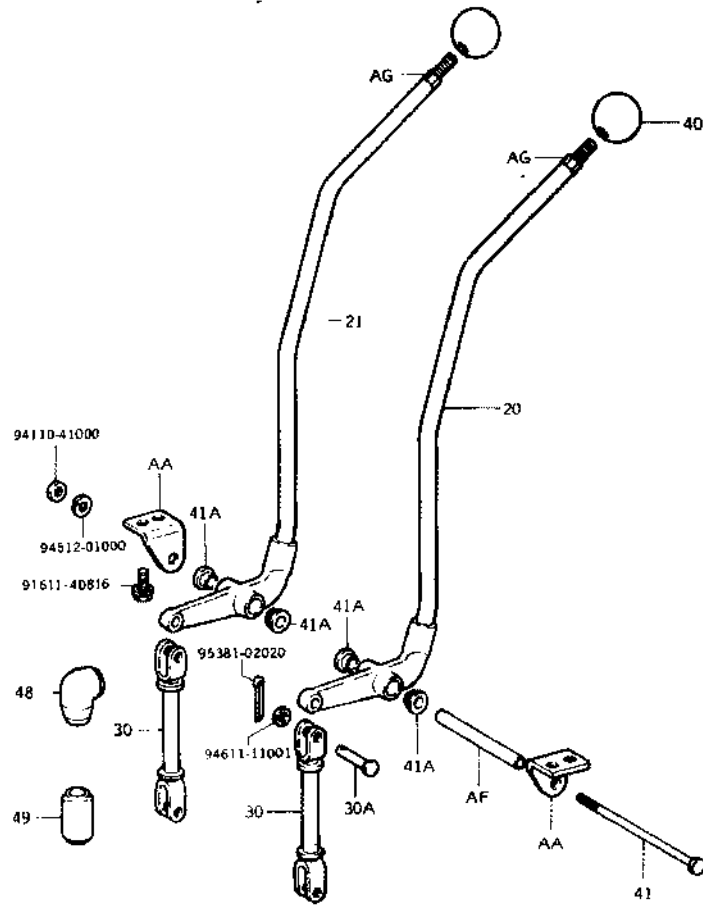

6709 016

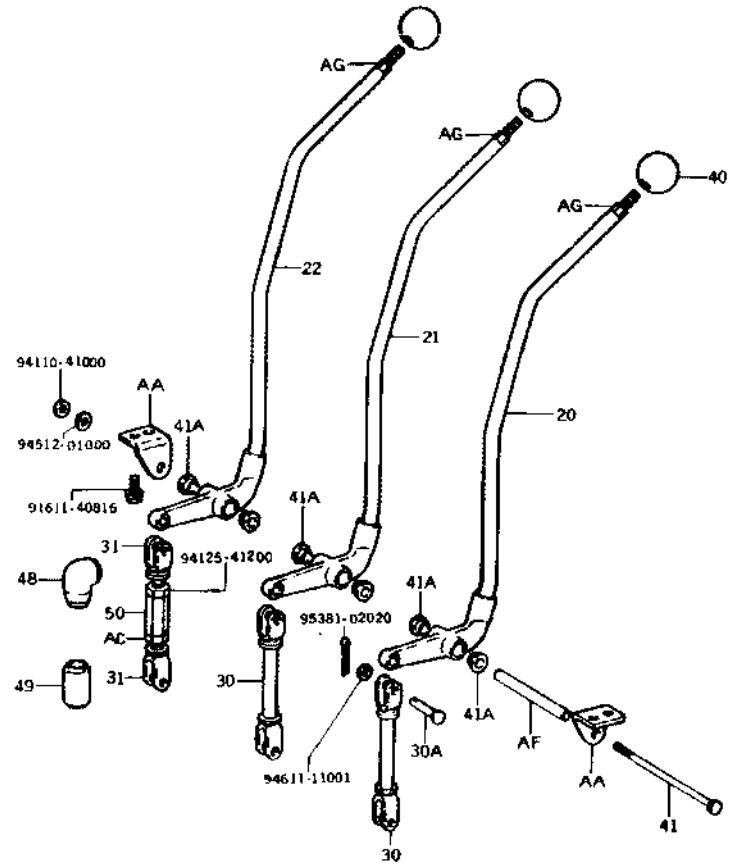

6709-017

FIG. 6709 OIL CONTROL VALVE LINK

6709

FV (4-WAY)

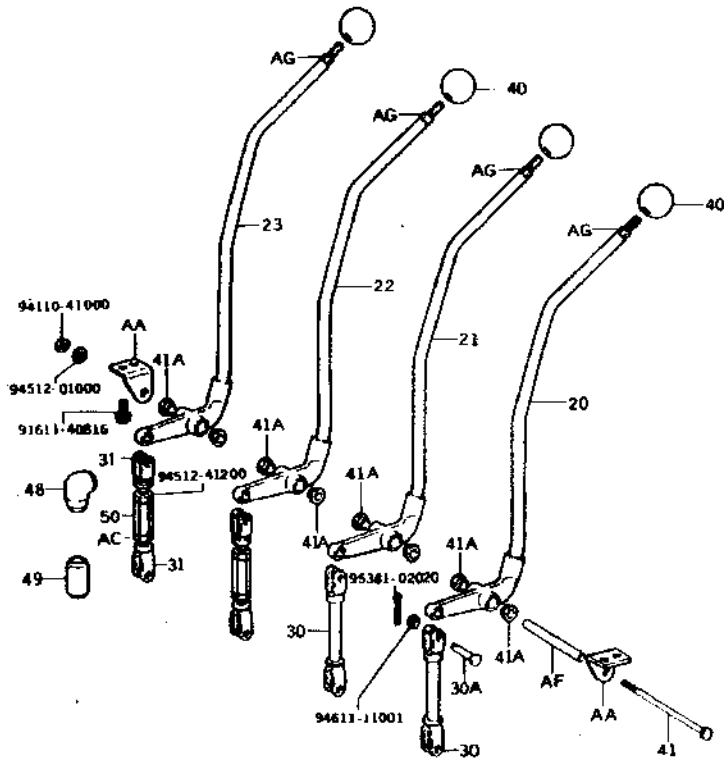

6709 018

PART NAME CODE	PART NAME	QTY
6709-20	LEVER SUB-ASSY, CONTROL VALVE, NO.1	1
6709-21	LEVER SUB-ASSY, CONTROL VALVE, NO.2	1
6709-22	LEVER SUB-ASSY, CONTROL VALVE, NO.3	1
6709-23	LEVER SUB-ASSY, CONTROL VALVE, NO.4	1
6709-30	ROD SUB-ASSY, CONTROL VALVE LEVER, NO.1	2
6709-30A	PIN (FOR CONTROL VALVE LEVER ROD)	4
6709-31	ROD SUB-ASSY, CONTROL VALVE LEVER, NO.2	1
6709-40	KNOB, OIL CONTROL VALVE LEVER	2
6709-41	PIN, OIL CONTROL VALVE LEVER	1
6709-41A	BUSH (FOR LEVER PIN)	4
6709-48	BOOT, CONTROL VALVE LINK, NO.1	2
6709-49	BOOT, CONTROL VALVE LINK, NO.2	2
6709-50	TURNBUCKLE	1
6709-AA	BRACKET SUB-ASSY	1
6709-AC	NUT	1
6709-AF	SPACER	1
6709-AG	BOLT, STUD	2

(FV) (10)

G210

FIG. 8801 BODY PIPING

6801

FV

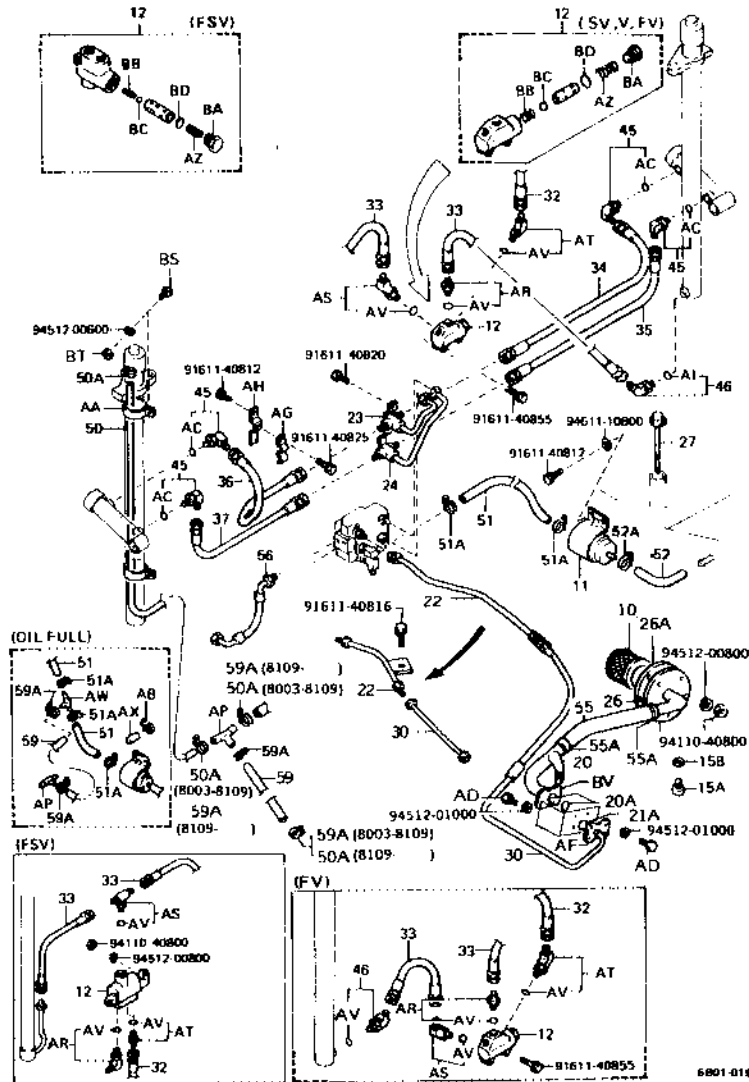

PART NAME CODE	PART NAME	QTY
6801-10	FILTER ASSY, SUCTION	1
6801-11	FILTER ASSY, RETURN	1
6801-12	VALVE ASSY, FLOW REGULATOR	1
6801-15A	PLUG (FOR OIL TANK DRAIN)	1
6801-15B	GASKET (FOR OIL TANK DRAIN PLUG)	1
6801-20	PIPE SUB-ASSY (PUMP INLET)	1
6801-20A	RING, O (FOR OIL PUMP INLET)	1
6801-21A	RING, O (FOR OIL PUMP OUTLET)	1
6801-22	PIPE SUB-ASSY (PUMP TO VALVE)	1
6801-23	PIPE SUB-ASSY (TILT CYLINDER FRONT)	1
6801-24	PIPE SUB-ASSY (TILT CYLINDER REAR)	1
6801-26	OUTLET SUB-ASSY, OIL TANK	1
6801-26A	PACKING, OIL TANK COVER	1
6801-27	CAP SUB-ASSY, OIL TANK	1
6801-30	HOSE, HIGH PRESSURE, NO.1 (PUMP TO VALVE)	1
6801-32	HOSE, HIGH PRESSURE, NO.1 (VALVE TO LIFT)	1
6801-33	HOSE, HIGH PRESSURE, NO.2 (VALVE TO LIFT)	1
6801-34	HOSE, HIGH PRESSURE, NO.1 (TILT FRONT)	1
6801-35	HOSE, HIGH PRESSURE, NO.1 (TILT REAR)	1
6801-36	HOSE, HIGH PRESSURE, NO.2 (TILT FRONT)	1
6801-37	HOSE, HIGH PRESSURE, NO.2 (TILT REAR)	1
6801-45	FITTING (FOR TILT CYLINDER)	2
6801-46	FITTING (FOR LIFT CYLINDER)	1
6801-51A	CLAMP (FOR VALVE TO TANK NO.1 HOSE)	2
6801-52	HOSE, LOW PRESSURE, NO.2 (VALVE TO TANK)	1
6801-52A	CLAMP (FOR VALVE TO TANK NO.2 HOSE)	2
6801-55	HOSE, LOW PRESSURE (TANK TO PUMP)	1
6801-55A	CLAMP (FOR TANK TO PUMP HOSE)	2
6801-56	HOSE, LOW PRESSURE (STEERING TO VALVE)	1
6801-AD	CLAMP	1
6801-AC	RING, O	4
6801-AD	BOLT	8
6801-AF	FLANGE, SPLIT	1
6801-AG	CLAMP	1
6801-AH	BRACKET SUB-ASSY, TILT HOSE	1
6801-AI	RING, O	1
6801-AR	FITTING	1
6801-AS	FITTING	1
6801-AT	FITTING	1
6801-AV	RING, O	4
6801-AX	CAP, OIL TANK OVERFLOW PIPE	1
6801-AZ	SPRING, COMPRESSION	1
6801-BA	PLUG	1
6801-BB	SPRING, COMPRESSION	1
6801-BC	BALL, STEEL	1
6801-BD	RING, O	1
6801-BS	BOLT	1
6801-BT	WASHER	1
6801-BV	FLANGE	2

(FV) (11)

G210

FIG. 6802 MAST PIPING

6802

FV

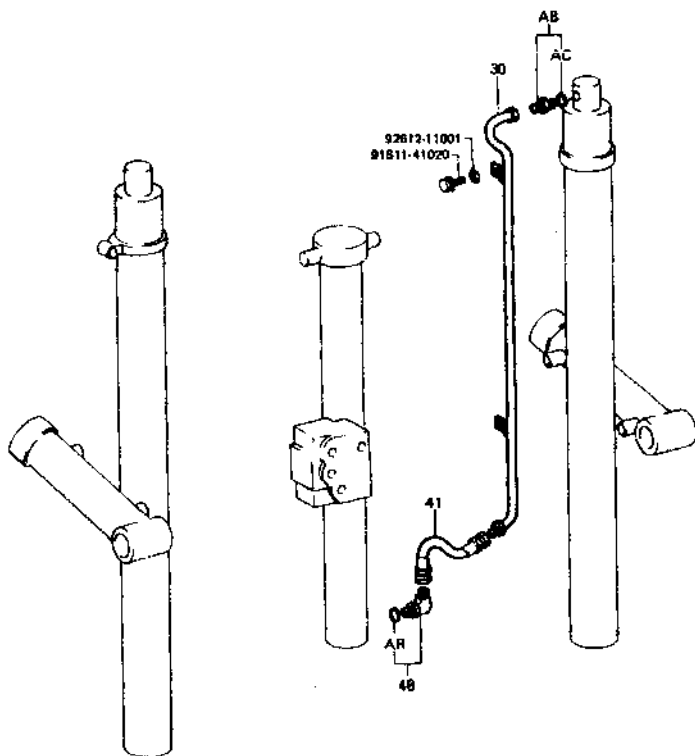

6802-029 A

PART NAME CODE	PART NAME	QTY
6802-30	PIPE SUB-ASSY, NO.1 (FRONT LIFT) -----	1
6802-41	HOSE, HIGH PRESSURE, NO.1 (FRONT LIFT) -----	1
6802-48	FITTING (FOR FRONT LIFT CYLINDER) -----	1
6802-AB	FITTING -----	1
6802-AC	RING, Ø -----	2

FIG. 6101 MAST

6101

M

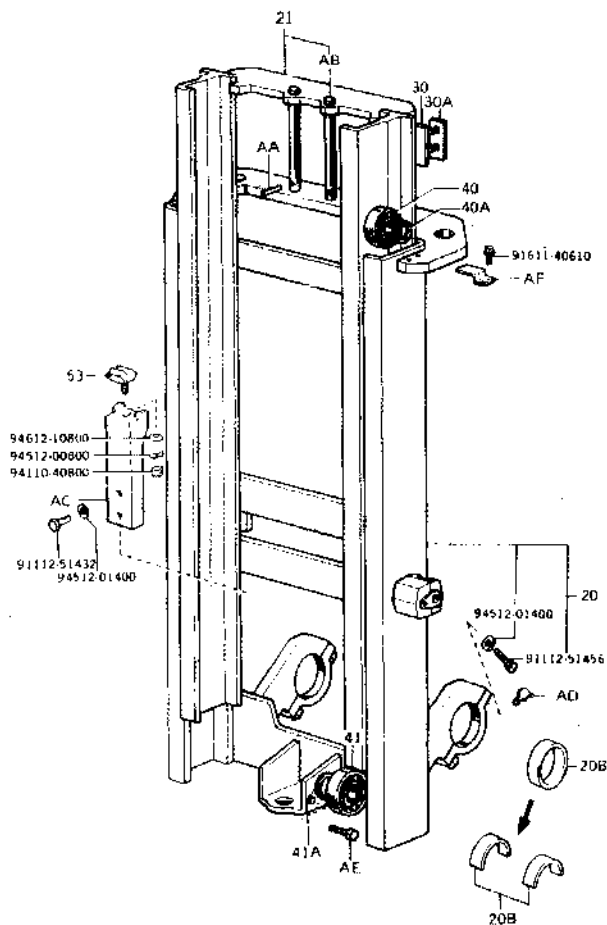

PART NAME CODE	PART NAME	QTY
6101-20	MAST SUB-ASSY, OUTER -----	1
6101-20B	BUSH, MAST SUPPORT -----	1
6101-21	MAST SUB-ASSY, INNER -----	1
6101-30	STRIP SUB-ASSY, OUTER MAST -----	2
6101-30A	SHIM, OUTER MAST STRIP -----	99
6101-40	ROLLER, LIFT (FOR OUTER MAST) -----	2
6101-40A	SHIM, LIFT ROLLER (FOR OUTER MAST) -----	99
6101-41	ROLLER, LIFT (FOR INNER MAST) -----	2
6101-41A	SHIM, LIFT ROLLER (FOR INNER MAST) -----	99
6101-53	CUSHION, MAST (FOR INNER MAST) -----	2
6101-AA	PIN, SPRING -----	2
6101-AB	GUIDE, CHAIN WHEEL SUPPORT -----	2
6101-AC	STOPPER, INNER MAST -----	2
6101-AD	FITTING, GREASE -----	2
6101-AE	BOLT, STOPPER -----	2
6101-AF	COVER, ROLLER -----	2

6101-090

FIG. 6301 LIFT BRACKET & FORK

6301

M

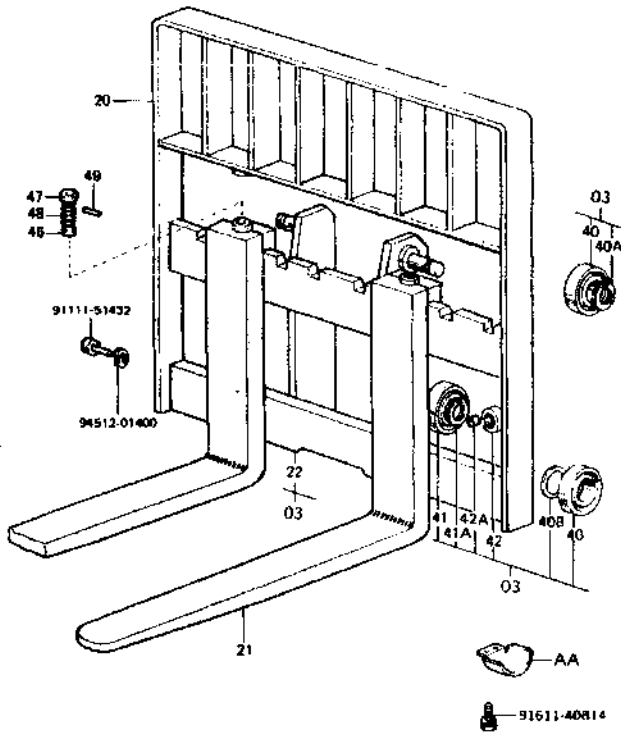

6301-042

PART NAME CODE	PART NAME	QTY
6301-03	BRACKET ASSY, LIFT -----	1
6301-20	BACKREST SUB-ASSY -----	1
6301-21	FORK SUB-ASSY -----	2
6301-22	BRACKET SUB-ASSY, LIFT -----	1
6301-40	ROLLER, LIFT (UPPER, LOWER) -----	4
6301-40A	RING, SHAFT SNAP (UPPER, LOWER) -----	2
6301-40B	SHIM, LIFT ROLLER -----	99
6301-41	ROLLER, LIFT (CENTER) -----	2
6301-41A	RING, SHAFT SNAP (CENTER) -----	2
6301-42	ROLLER, SIDE -----	2
6301-42A	SHIM (FOR SIDE ROLLER) -----	99
6301-46	PIN, FORK STOPPER -----	2
6301-47	KNOB, FORK STOPPER PIN -----	2
6301-48	SPRING, FORK STOPPER PIN -----	2
6301-49	PIN, SPRING (FOR FORK STOPPER PIN) -----	2
6301-AA	COVER, LIFT BRACKET ROLLER -----	4

(M) (2)

G210

FIG. 6302 CHAIN & CHAIN WHEEL

6302

M

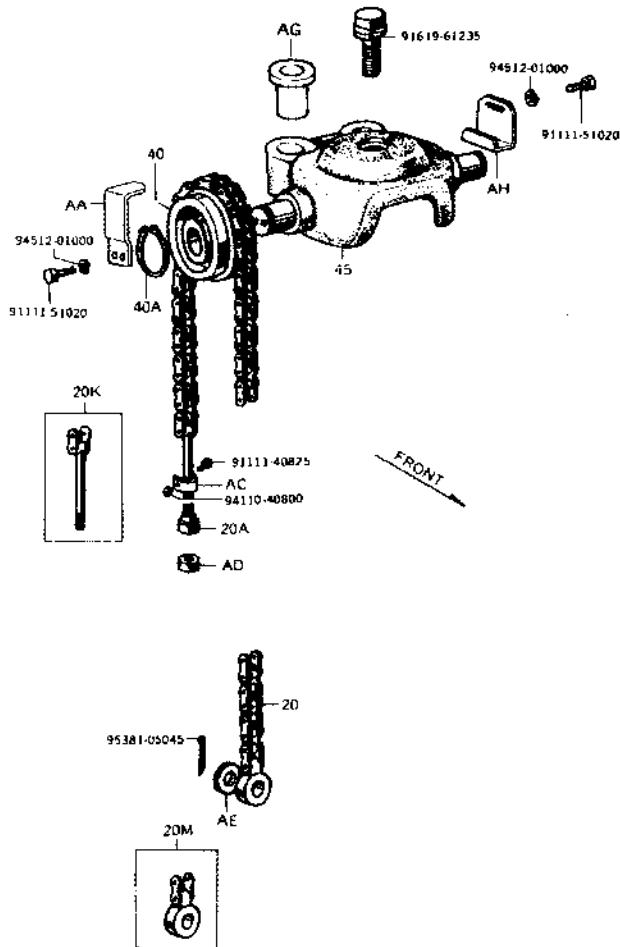

PART NAME CODE	PART NAME	QTY
6302-20	CHAIN SUB-ASSY -----	2
6302-20A	NUT, CHAIN ADJUST -----	2
6302-20K	BOLT KIT, CHAIN ANCHOR, NO.1 -----	2
6302-20M	BOLT KIT, CHAIN EYE -----	2
6302-40	WHEEL, CHAIN -----	2
6302-40A	RING, SHAFT SNAP (FOR CHAIN WHEEL) -----	2
6302-45	SUPPORT, CHAIN WHEEL -----	1
6302-AA	PLATE, CHAIN STOPPER -----	2
6302-AC	CLAMP, CHAIN ANCHOR BOLT -----	2
6302-AD	NUT, HEXAGON -----	2
6302-AE	WASHER, CHAIN SPECIAL -----	2
6302-AG	BUSHING -----	2
6302-AH	COVER, CHAIN WHEEL -----	2

6302-040

FIG. 6504 LIFT CYLINDER

6504

M

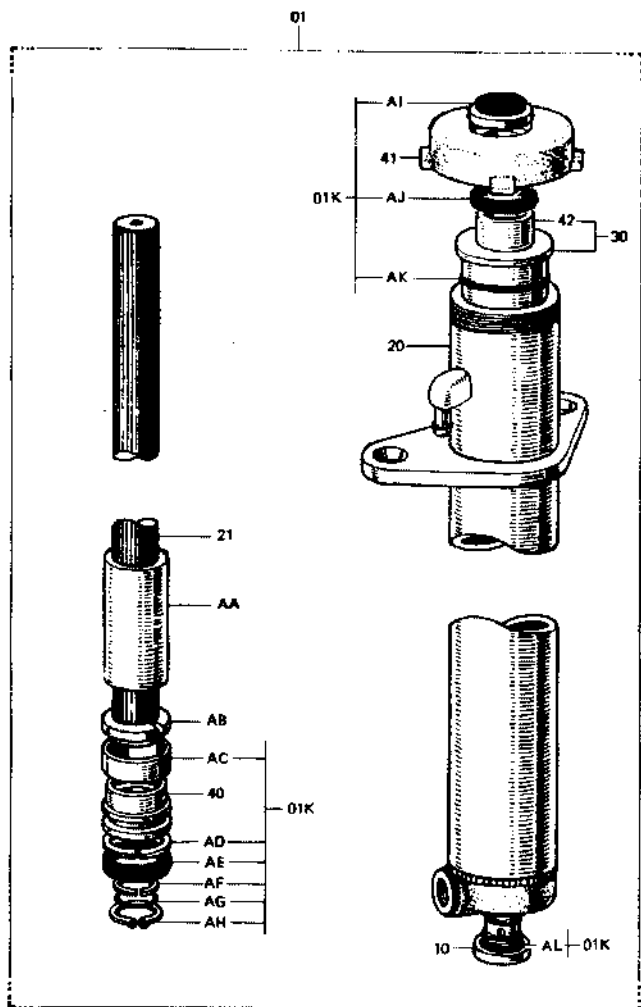

6504-001

PART NAME CODE	PART NAME	QTY
6504-01	CYLINDER ASSY, LIFT -----	1
6504-01K	CYLINDER O/H KIT, LIFT -----	1
6504-10	VALVE ASSY, FLOW REGULATOR -----	1
6504-20	CYLINDER SUB-ASSY, LIFT -----	1
6504-21	ROD SUB-ASSY, LIFT CYLINDER PISTON -----	1
6504-30	GUIDE SUB-ASSY, LIFT CYLINDER ROD -----	1
6504-40	PISTON, LIFT CYLINDER -----	1
6504-41	COVER, LIFT CYLINDER -----	1
6504-42	SLEEVE, LIFT CYLINDER ROD GUIDE -----	1
6504-AA	SPACER, LIFT CYLINDER -----	1
6504-AB	RING, STOPPER -----	1
6504-AC	RING, WEAR -----	1
6504-AD	RING, BACK UP -----	1
6504-AE	PACKING, U -----	1
6504-AF	RING, BACK UP -----	1
6504-AG	RING, O -----	1
6504-AH	RING, SHAFT SNAP -----	1
6504-AI	SEAL, DUST -----	1
6504-AJ	PACKING, U -----	1
6504-AK	RING, O -----	1
6504-AL	RING, O -----	1

(M) (4) G210

FIG. 6511 TILT CYLINDER

6511

M

M

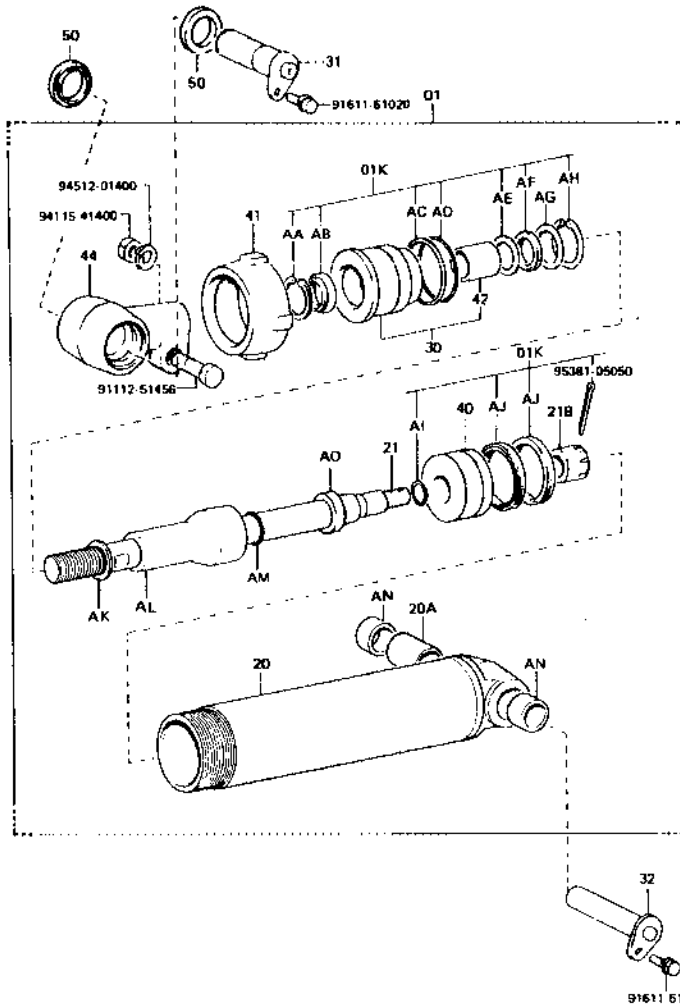

91611 61020

6511 010

テイルト角度表
TABLE OF TILT RANGE

生産期間 PROD DATE	型式 MODELS	タイヤ TIRE	揚 高 LIFTING HEIGHT	備 考 DESCRIPTION	テイルト角 TILT RANGE
8009	F, FV, M, SV, V	SINGLE	H2000-H4000		60 - 120
8009	F, FV, M, SV, V	DOUBLE	H2000-H4500		60 - 120
8009	F, FV, M, SV, V	SINGLE	H4500-H5000		60 - 80
8009	F, FV, M, SV, V	DOUBLE	H5000		60 - 60
8009	F, FV, M, SV, V		H2000	FRONT GLASS	60 - 100
8009	FSV, FS		H3700-H6500		60 - 60
8009	F, FV, M, SV, V	SINGLE	H2000-H4000	AUSTRALIA	30 - 120
8009	F, FV, M, SV, V	DOUBLE	H2000-H4500	AUSTRALIA	30 - 120
8009	F, FV, M, SV, V	SINGLE	H4500-H5000	AUSTRALIA	30 - 60
8009	F, FV, M, SV, V	DOUBLE	H6000	AUSTRALIA	30 - 60
8009	F, FV, M, SV, V		H2000	FRONT GLASS AUSTRALIA	30 - 100
8009	FV, M, SV, V		H3700-H6500	AUSTRALIA	30 - 60

6511-019

FIG. 6511 TILT CYLINDER

6511

M

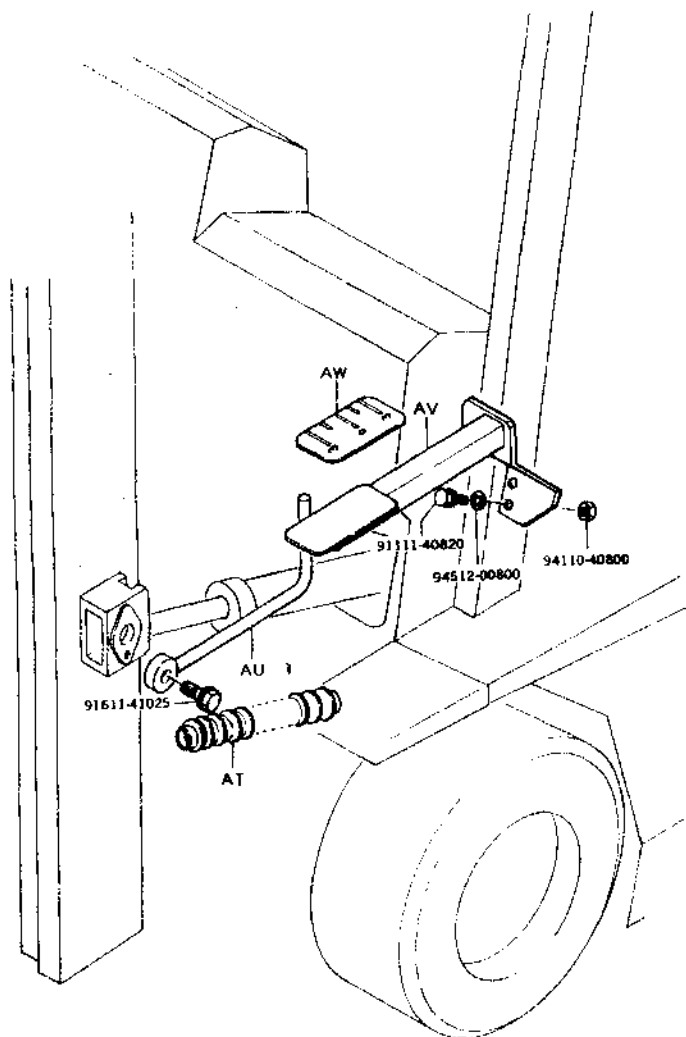

6511 013

PART NAME CODE	PART NAME	QTY
6511-01	CYLINDER ASSY, TILT -----	2
6511-01K	CYLINDER O/H KIT, TILT -----	2
6511-20	CYLINDER SUB-ASSY, TILT -----	2
6511-20A	BUSH, PIN (FOR CYLINDER) -----	2
6511-21	ROD SUB-ASSY, TILT CYLINDER PISTON -----	2
6511-21B	NUT, CASTLE -----	2
6511-30	GUIDE SUB-ASSY, TILT CYLINDER ROD -----	2
6511-31	PIN SUB-ASSY, TILT CYLINDER -----	2
6511-32	PIN SUB-ASSY, TILT CYLINDER, RR -----	2
6511-40	PISTON, TILT CYLINDER -----	2
6511-41	COVER, TILT CYLINDER -----	2
6511-42	SLEEVE, TILT CYLINDER ROD GUIDE -----	2
6511-44	JOINT, PISTON ROD -----	2
6511-50	SEAL, GREASE -----	2
6511-AA	RING, HOLE SNAP -----	2
6511-AB	SEAL, DUST -----	2
6511-AC	RING, BACK UP -----	2
6511-AD	RING, O -----	2
6511-AE	RING, BACK UP -----	2
6511-AF	PACKING, U -----	2
6511-AG	PLATE, STOPPER -----	2
6511-AH	RING, HOLE SNAP -----	2
6511-AI	RING, O -----	2
6511-AJ	PACKING, U -----	4
6511-AK	SHIM, TILT CONTROL -----	99
6511-AL	SPACER, TILT CONTROL -----	2
6511-AM	RING, O -----	4
6511-AN	COLLAR -----	4
6511-AO	SPACER, TILT CONTROL -----	2
6511-AT	BOOT SUB-ASSY -----	2
6511-AU	BAR SUB-ASSY, TILT GAUGE -----	1
6511-AV	BRACKET SUB-ASSY, TILT GAUGE -----	1
6511-AW	PLATE, TILT CYLINDER INDICATOR -----	1

(M) (5)

G210

FIG. 6701 OIL PUMP

6701

M

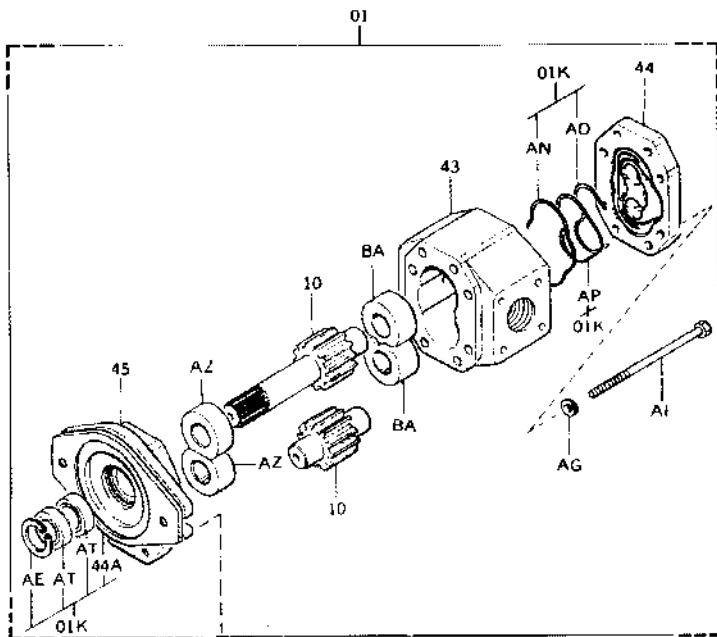

- -91111-51025
- -94612-11000
- -94512-01000

6701-012

PART NAME Code	PART NAME	QTY
6701-01	PUMP ASSY, OIL -----	1
6701-01K	PUMP G/R KIT, OIL -----	1
6701-10	GEAR SET -----	1
6701-11	BUSH SET, NO.1 -----	2
6701-43	BODY -----	1
6701-44	FLANGE, MOUNTING -----	1
6701-45	COVER -----	1
6701-AA	SEAL, BUSHING -----	2
6701-AB	RING, BACKING, RH -----	2
6701-AC	RING, BACKING, LH -----	2
6701-AD	SEAL, OIL -----	1
6701-AE	RING, SNAP -----	1
6701-AF	BOLT -----	4
6701-AG	WASHER, SPRING -----	4
6701-AH	SEAL, BODY -----	2
6701-AI	BOLT -----	2

(M) (6)

G210

FIG. 6705 OIL CONTROL VALVE

6705

M

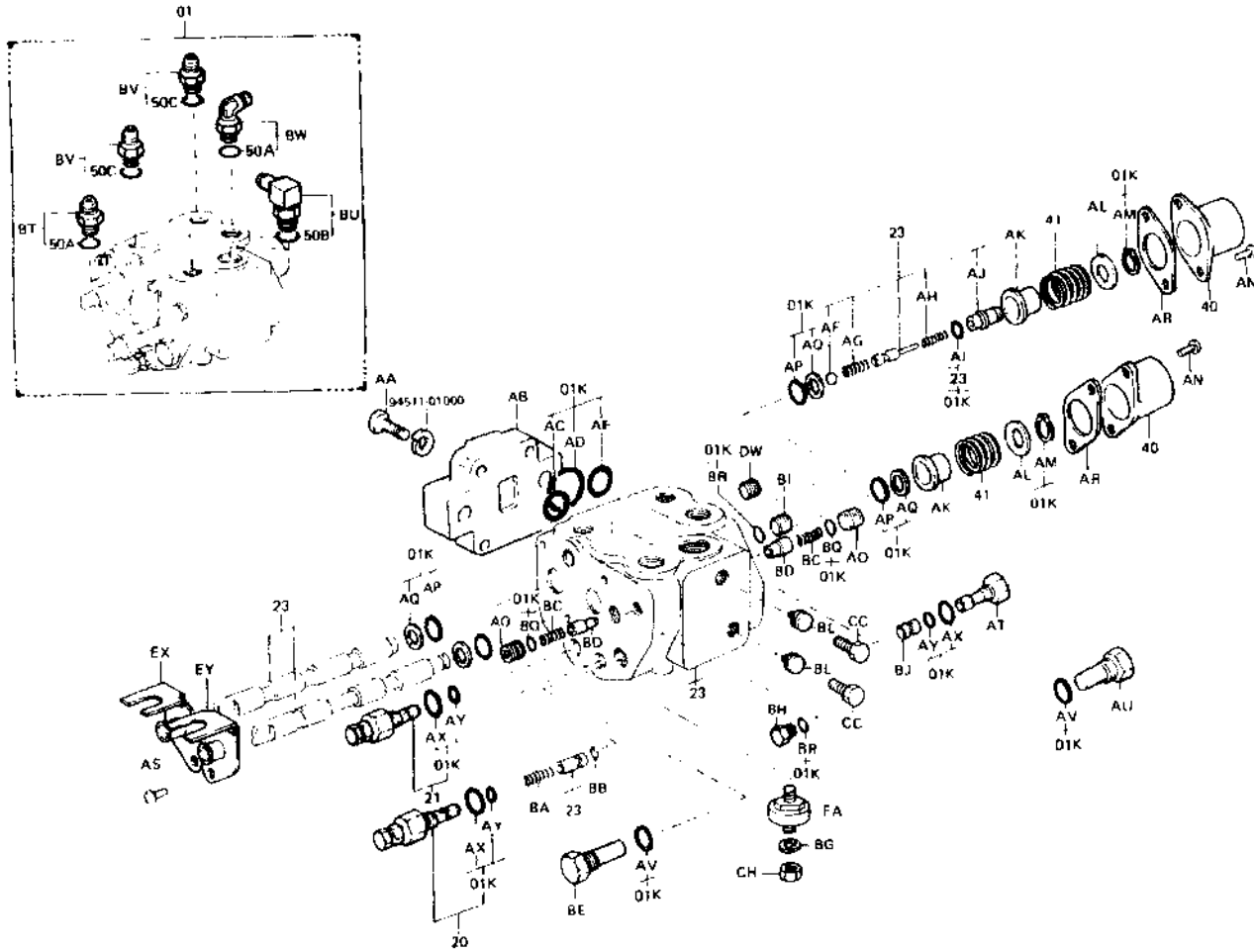

FIG. 6705 OIL CONTROL VALVE

6705

M (3-WAY UL-EE)

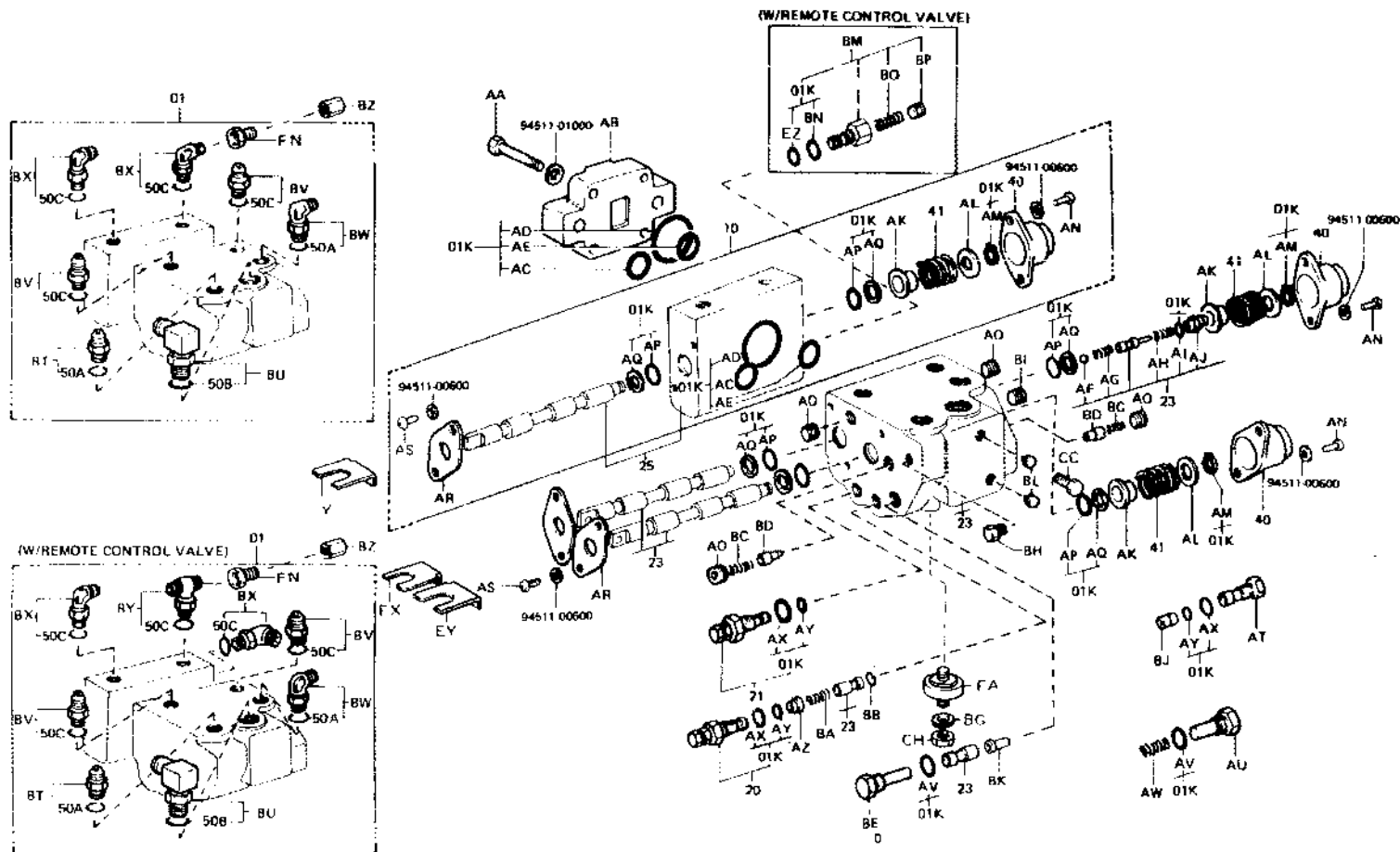

FIG. 6705 OIL CONTROL VALVE

6705

M (3-WAY)

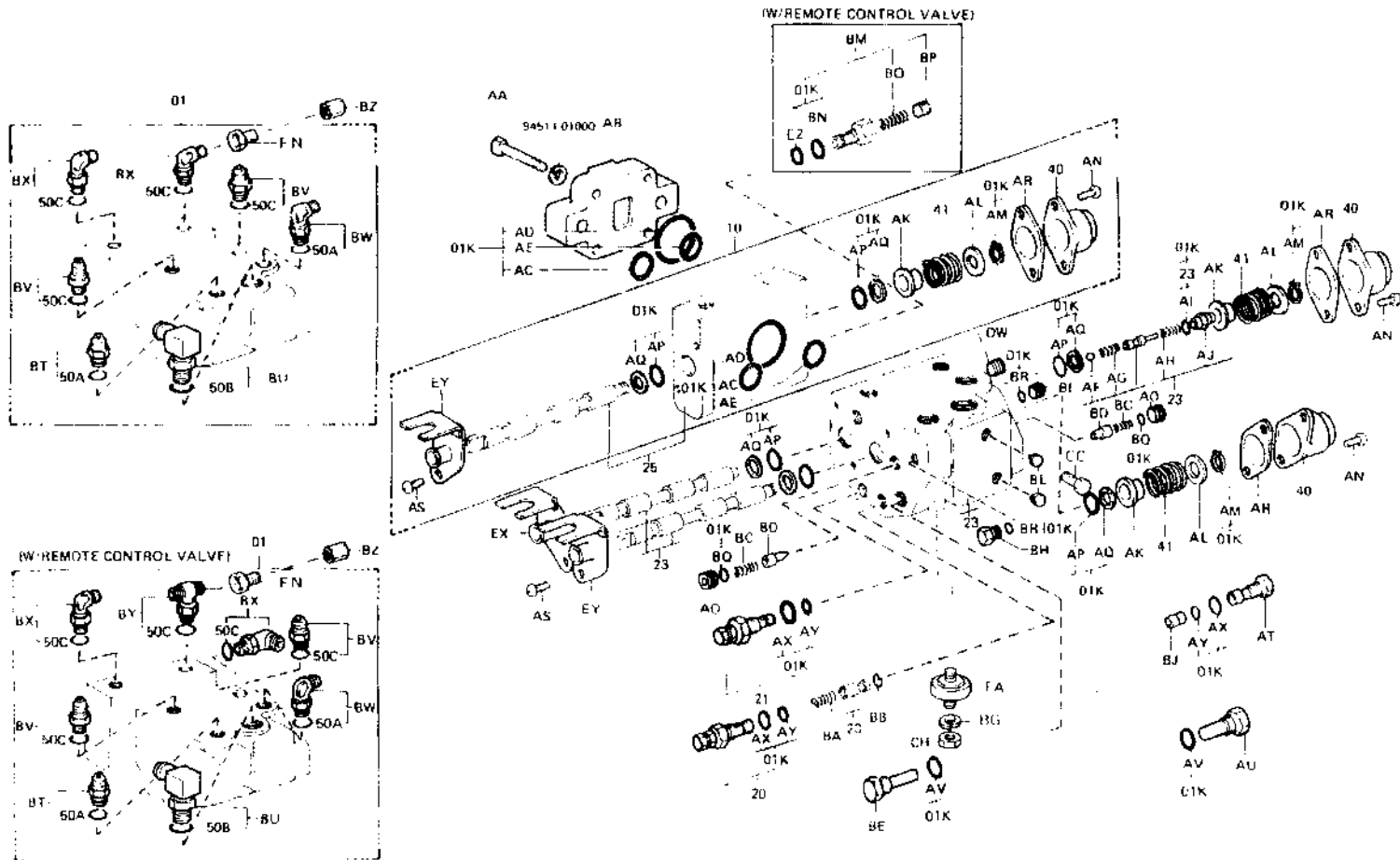

FIG. 6705 OIL CONTROL VALVE

6705

M (4-WAY)

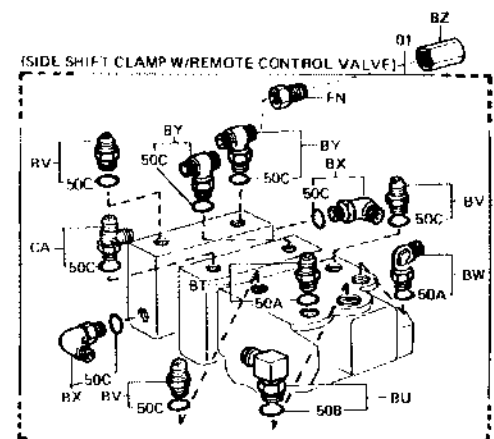
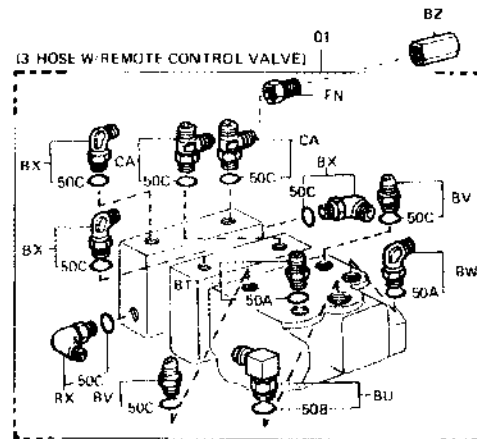
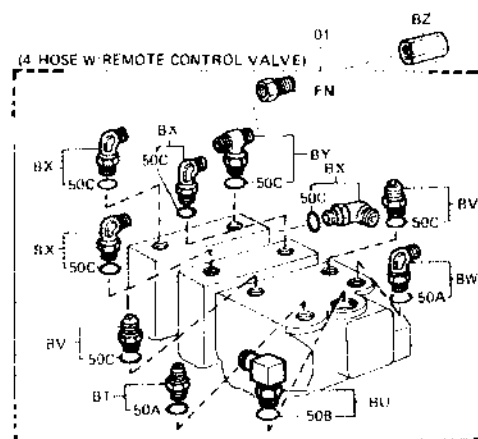
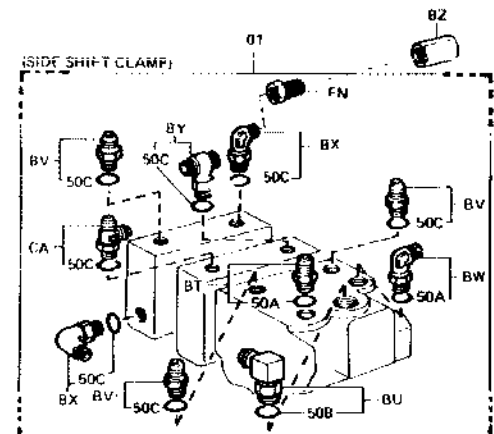
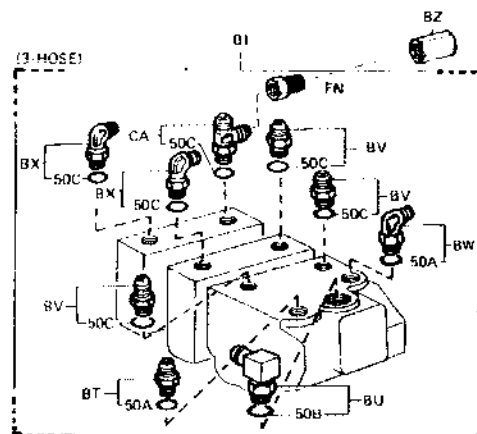
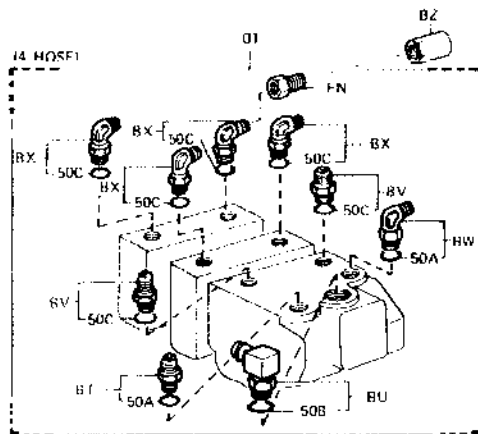
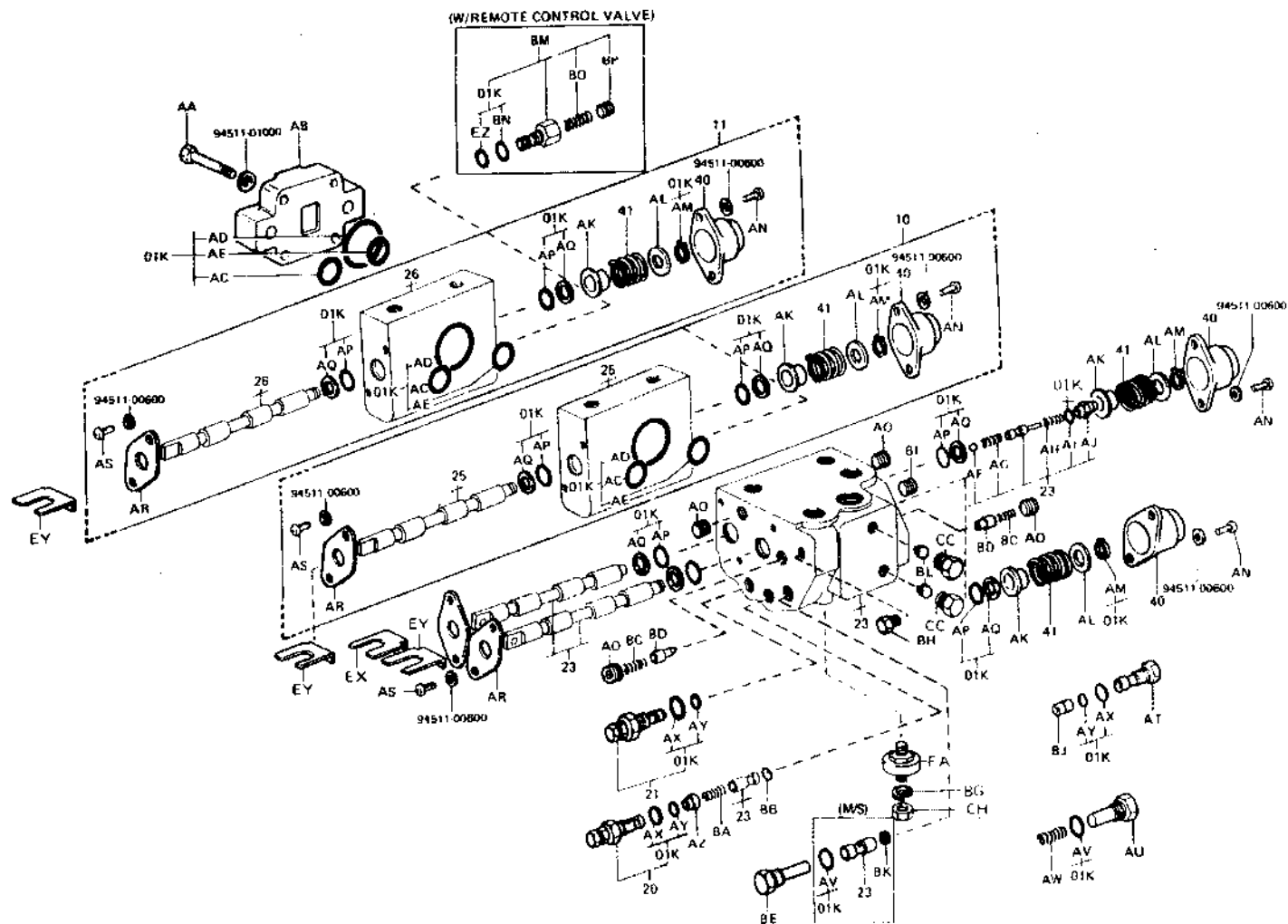

FIG. 6705 OIL CONTROL VALVE

6705

M (4-WAY UL-EE)



6705

PART NAME CODE	PART NAME	QTY
6705-01	VALVE ASSY, OIL CONTROL -----	1
6705-01K	VALVE O/H KIT, OIL CONTROL -----	1
6705-10	VALVE ASSY, PLUNGER SECTION, NO.1 -----	1
6705-11	VALVE ASSY, PLUNGER SECTION, NO.2 -----	1
6705-20	VALVE SET, PILOT RELIEF, NO.1 -----	1
6705-21	VALVE SET, PILOT RELIEF, NO.2 -----	1
6705-23	HOUSING & SPOOL SET, NO.1 -----	1
6705-25	HOUSING & SPOOL SET, ATTACHMENT, NO.1 -----	1
6705-26	HOUSING & SPOOL SET, ATTACHMENT, NO.2 -----	1
6705-40	COVER, SPRING -----	2
6705-41	SPRING, COMPRESSION (FOR SPOOL RETURN) -----	2
6705-50A	RING, O, NO.1 (FOR VALVE FITTING) -----	2
6705-50B	RING, O, NO.2 (FOR VALVE FITTING) -----	1
6705-50C	RING, O, NO.3 (FOR VALVE FITTING) -----	2
6705-AA	BOLT -----	4
6705-AB	HOUSING, OUTLET -----	1
6705-AC	RING, O -----	1
6705-AD	RING, O -----	1
6705-AE	RING, O -----	1
6705-AF	BALL, STEEL -----	1
6705-AG	SPRING -----	1
6705-AH	SPRING, COMPRESSION -----	1
6705-AI	RING, O -----	1
6705-AJ	STOPPER -----	1
6705-AK	HOLDER, SPRING -----	2
6705-AL	WASHER, PLATE -----	2
6705-AM	RING, SHAFT SNAP -----	2
6705-AN	SCREW -----	4
6705-AO	PLUG -----	2
6705-AP	RING, O -----	4
6705-AQ	RING, BACK UP -----	4
6705-AR	HOLDER, SEAL -----	2
6705-AS	SCREW -----	4
6705-AT	STOPPER -----	1
6705-AU	STOPPER -----	1
6705-AV	RING, O -----	2
6705-AX	RING, O -----	3
6705-AY	RING, O -----	3
6705-BA	SPRING, COMPRESSION -----	1
6705-BB	WIRE, ORIFICE TURNING -----	1
6705-BC	SPRING, COMPRESSION -----	2
6705-BD	PLUNGER, CHECK -----	2
6705-BE	STOPPER -----	1
6705-BG	WASHER -----	4
6705-BH	PLUG -----	1
6705-BI	PLUG -----	1
6705-BJ	SEAT, VALVE -----	1
6705-BL	SEAT, INSERT -----	2
6705-BM	VALVE SUB-ASSY, RELIEF -----	1
6705-BN	RING, O -----	1
6705-BO	SPRING -----	1
6705-BP	STOPPER -----	1
6705-BQ	RING, O -----	2

(M) (7) G210

PART NAME CODE	PART NAME	QTY
6705-BR	RING, O -----	2
6705-BT	FITTING -----	1
6705-BU	FITTING -----	1
6705-BV	FITTING -----	2
6705-BW	FITTING -----	1
6705-BX	FITTING -----	2
6705-BY	FITTING -----	1
6705-BZ	PLUG -----	2
6705-CA	FITTING -----	1
6705-CC	PLUG -----	2
6705-CH	NUT -----	4
6705-DW	PLUG -----	1
6705-EX	BRACKET SUB ASSY, TILT -----	1
6705-EY	BRACKET SUB-ASSY, LIFT -----	1
6705-EZ	RING, O -----	1
6705-FA	INSULATOR -----	4
6705-FN	FITTING -----	2

(M) (8) G210

FIG. 6709 OIL CONTROL VALVE LINK

6709

M

M (3-WAY)

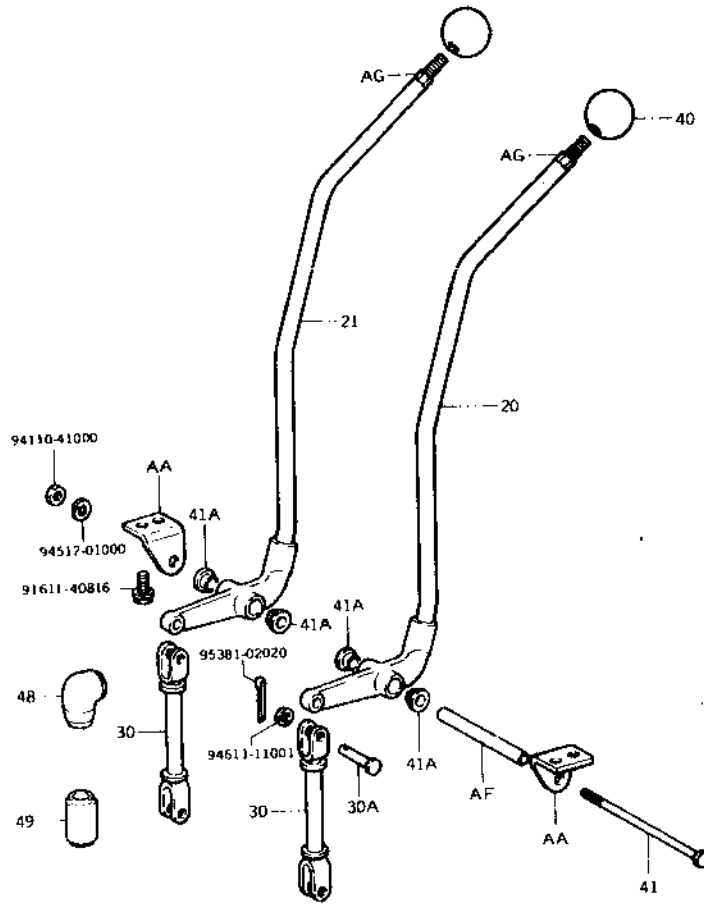

6709 016

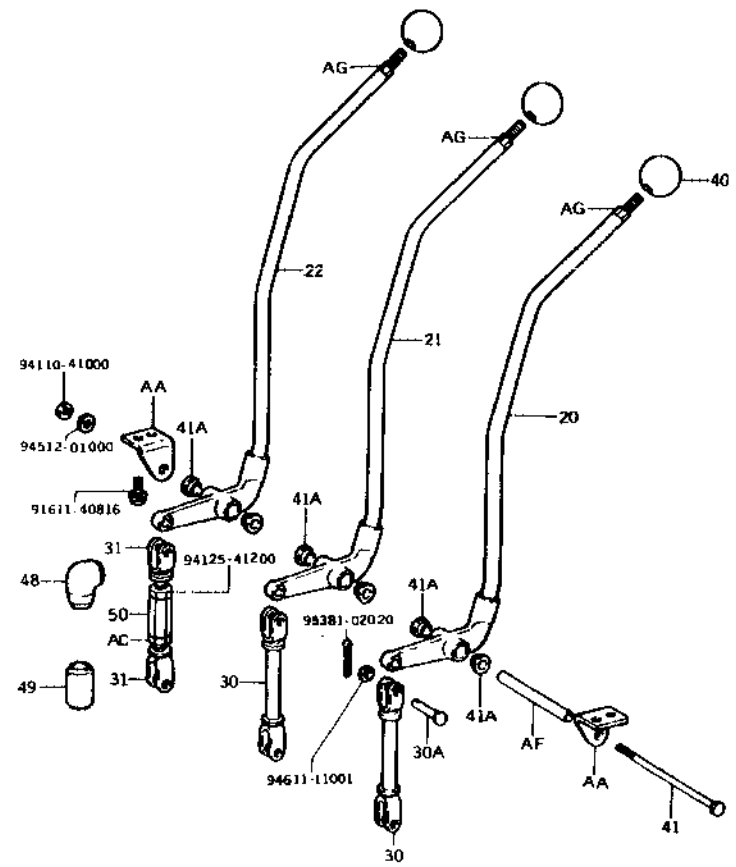

6709 017

FIG. 6709 OIL CONTROL VALVE LINK

6709

M (4-WAY)

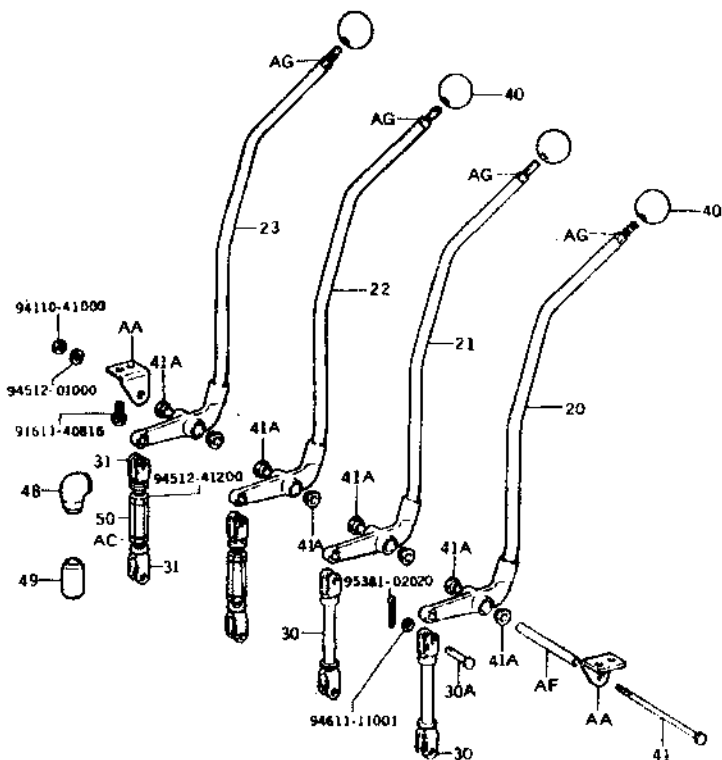

6709-019

PART NAME CODE	PART NAME	QTY
6709-20	LEVER SUB-ASSY, CONTROL VALVE, NO.1	1
6709-21	LEVER SUB-ASSY, CONTROL VALVE, NO.2	1
6709-22	LEVER SUB-ASSY, CONTROL VALVE, NO.3	1
6709-23	LEVER SUB-ASSY, CONTROL VALVE, NO.4	1
6709-30	ROD SUB-ASSY, CONTROL VALVE LEVER, NO.1	2
6709-30A	PIN (FOR CONTROL VALVE LEVER ROD)	4
6709-31	ROD SUB-ASSY, CONTROL VALVE LEVER, NO.2	1
6709-40	KNOB, OIL CONTROL VALVE LEVER	2
6709-41	PIN, OIL CONTROL VALVE LEVER	1
6709-41A	BUSH (FOR LEVER PIN)	4
6709-48	BOOT, CONTROL VALVE LINK, NO.1	2
6709-49	BOOT, CONTROL VALVE LINK, NO.2	2
6709-50	TURNBUCKLE	1
6709-AA	BRACKET SUB-ASSY	1
6709-AC	NUT	1
6709-AF	SPACER	1
6709-AG	BOLT, STUD	2

(M) (9) G210

FIG. 6801 BODY PIPING

6801

M

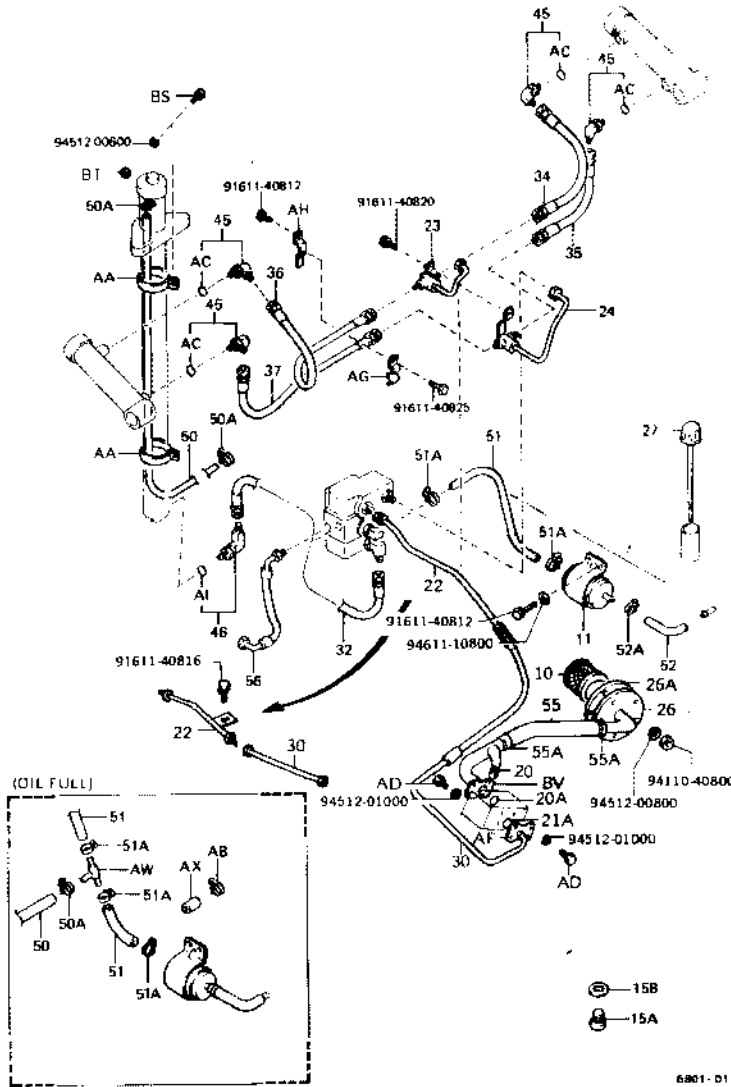

PART NAME CODE	PART NAME	QTY
6801-10	FILTER ASSY, SUCTION	1
6801-11	FILTER ASSY, RETURN	1
6801-15A	PLUG (FOR OIL TANK DRAIN)	1
6801-15B	GASKET (FOR OIL TANK DRAIN PLUG)	1
6801-20	PIPE SUB-ASSY (PUMP INLET)	1
6801-20A	RING, O (FOR OIL PUMP INLET)	1
6801-21A	RING, O (FOR OIL PUMP OUTLET)	1
6801-22	PIPE SUB-ASSY (PUMP TO VALVE)	1
6801-23	PIPE SUB-ASSY (TILT CYLINDER FRONT)	1
6801-24	PIPE SUB-ASSY (TILT CYLINDER REAR)	1
6801-26	OUTLET SUB-ASSY, OIL TANK	1
6801-26A	PACKING, OIL TANK COVER	1
6801-27	CAP SUB-ASSY, OIL TANK	1
6801-30	HOSE, HIGH PRESSURE, NO.1 (PUMP TO VALVE)	1
6801-32	HOSE, HIGH PRESSURE, NO.1 (VALVE TO LIFT)	1
6801-34	HOSE, HIGH PRESSURE, NO.1 (TILT FRONT)	1
6801-35	HOSE, HIGH PRESSURE, NO.1 (TILT REAR)	1
6801-36	HOSE, HIGH PRESSURE, NO.2 (TILT FRONT)	1
6801-37	HOSE, HIGH PRESSURE, NO.2 (TILT REAR)	1
6801-45	FITTING (FOR TILT CYLINDER)	2
6801-46	FITTING (FOR LIFT CYLINDER)	1
6801-50	HOSE, LOW PRESSURE, NO.1 (LIFT TO TANK)	1
6801-50A	CLAMP (FOR LIFT TO TANK NO.1 HOSE)	2
6801-51A	CLAMP (FOR VALVE TO TANK NO.1 HOSE)	2
6801-52	HOSE, LOW PRESSURE, NO.2 (VALVE TO TANK)	1
6801-52A	CLAMP (FOR VALVE TO TANK NO.2 HOSE)	2
6801-55	HOSE, LOW PRESSURE (TANK TO PUMP)	1
6801-55A	CLAMP (FOR TANK TO PUMP HOSE)	2
6801-56	HOSE, LOW PRESSURE (STEERING TO VALVE)	1
6801-AA	BAND, LIFT CYLINDER OVERFLOW HOSE	2
6801-AB	CLAMP	1
6801-AC	RING, O	4
6801-AD	BOLT	8
6801-AF	FLANGE, SPLIT	1
6801-AG	CLAMP	1
6801-AH	BRACKET SUB-ASSY, TILT HOSE	1
6801-AI	RING, O	1
6801-AW	ELBOW SUB-ASSY, 3-WAY	1
6801-AX	CAP, OIL TANK OVERFLOW PIPE	1
6801-BS	BOLT	1
6801-BT	WASHER	1
6801-BV	FLANGE	2

FIG. 6101 MAST

6101

SV

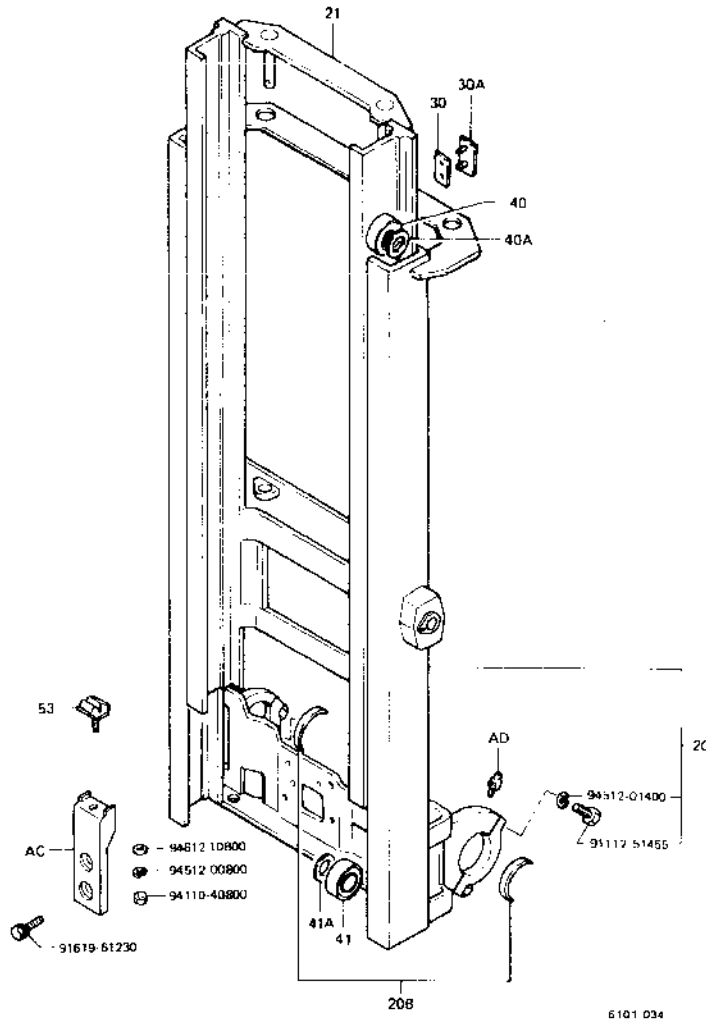

PART NAME CODE	PART NAME	QTY
6101-20	MAST SUB-ASSY, OUTER -----	1
6101-20B	BUSH, MAST SUPPORT -----	1
6101-21	MAST SUB-ASSY, INNER -----	1
6101-30	STRIP SUB-ASSY, OUTER MAST -----	2
6101-30A	SHIM, OUTER MAST STRIP -----	99
6101-40	ROLLER, LIFT (FOR OUTER MAST) -----	2
6101-40A	SHIM, LIFT ROLLER (FOR OUTER MAST) -----	99
6101-41	ROLLER, LIFT (FOR INNER MAST) -----	2
6101-41A	SHIM, LIFT ROLLER (FOR INNER MAST) -----	99
6101-53	CUSHION, MAST (FOR INNER MAST) -----	2
6101-AC	STOPPER, INNER MAST -----	2
6101-AD	FITTING, GREASE -----	2

FIG. 6301 LIFT BRACKET & FORK

6301

SV

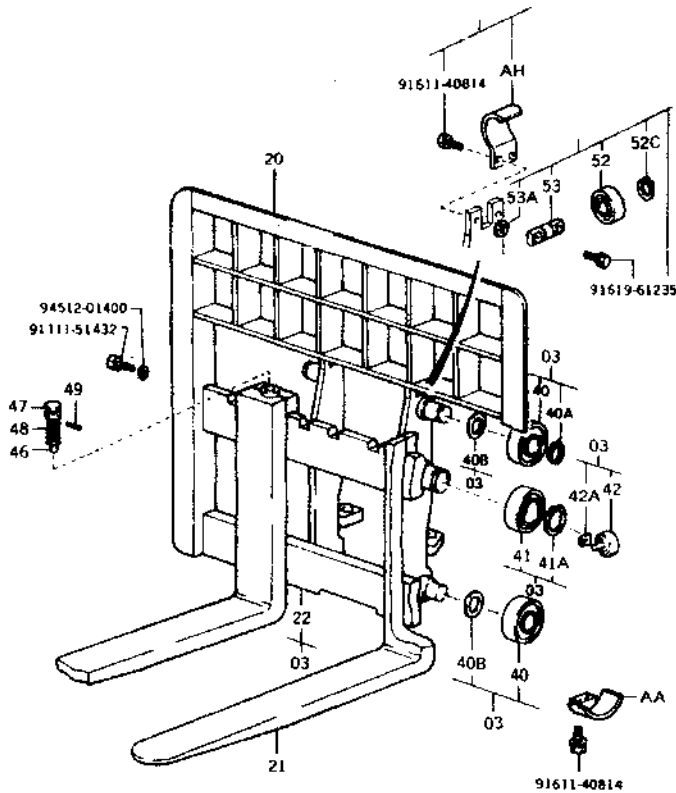

6301-026 A

PART NAME CODE	PART NAME	QTY
6301-03	BRACKET ASSY, LIFT -----	1
6301-20	BACKREST SUB-ASSY -----	1
6301-21	FORK SUB-ASSY -----	2
6301-22	BRACKET SUB-ASSY, LIFT -----	1
6301-40	ROLLER, LIFT (UPPER, LOWER) -----	4
6301-40A	RING, SHAFT SNAP (UPPER, LOWER) -----	2
6301-40B	SHIM, LIFT ROLLER -----	99
6301-41	ROLLER, LIFT (CENTER) -----	2
6301-41A	RING, SHAFT SNAP (CENTER) -----	2
6301-42	ROLLER, SIDE -----	2
6301-42A	SHIM (FOR SIDE ROLLER) -----	99
6301-46	PIN, FORK STOPPER -----	2
6301-47	KNOB, FORK STOPPER PIN -----	2
6301-48	SPRING, FORK STOPPER PIN -----	2
6301-49	PIN, SPRING (FOR FORK STOPPER PIN) -----	2
6301-52	ROLLER, SIDE, NO.2 -----	2
6301-52C	RING, SHAFT SNAP (FOR SIDE ROLLER) -----	4
6301-53	PIN, SIDE ROLLER -----	2
6301-53A	SHIM (FOR SIDE ROLLER PIN) -----	99

(SV) (2)

G210

FIG. 6302 CHAIN & CHAIN WHEEL

6302

SV

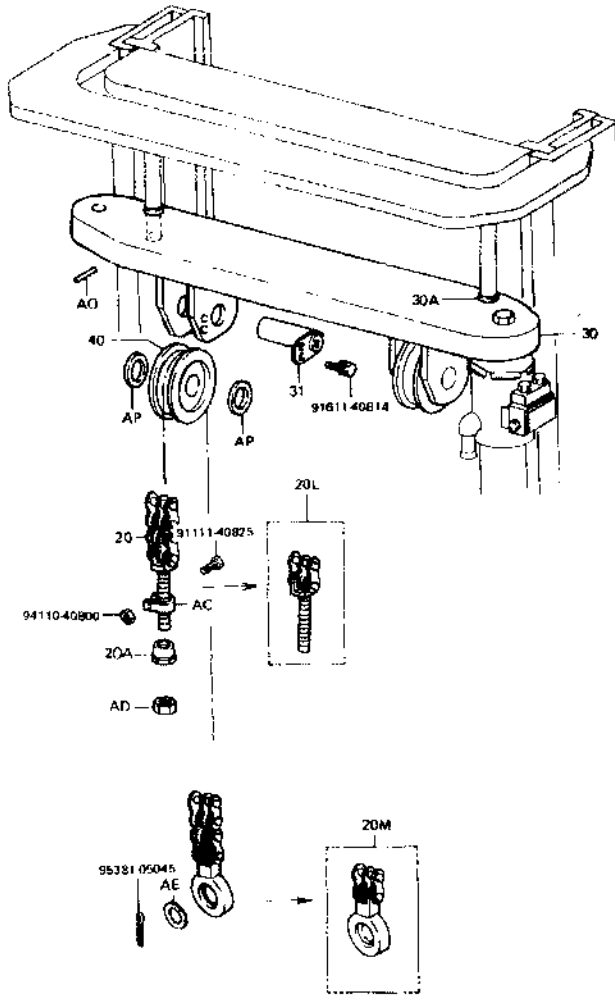

PART NAME CODE	PART NAME	QTY
6302-20	CHAIN SUB-ASSY -----	2
6302-20A	NUT, CHAIN ADJUST -----	2
6302-20L	BOLT KIT, CHAIN ANCHOR, NO.2 -----	2
6302-20M	BOLT KIT, CHAIN EYE -----	2
6302-30	BEAM SUB-ASSY, CHAIN -----	1
6302-30A	BUSHING -----	2
6302-31	PIN SUB-ASSY, CHAIN WHEEL -----	2
6302-40	WHEEL, CHAIN -----	2
6302-AC	CLAMP, CHAIN ANCHOR BOLT -----	2
6302-AD	NUT, HEXAGON -----	2
6302-AE	WASHER, CHAIN SPECIAL -----	2
6302-AO	PIN, SPRING -----	2
6302-AP	COLLAR, CHAIN WHEEL -----	4

6302-037A

FIG. 6501 LIFT CYLINDER

6501

SV

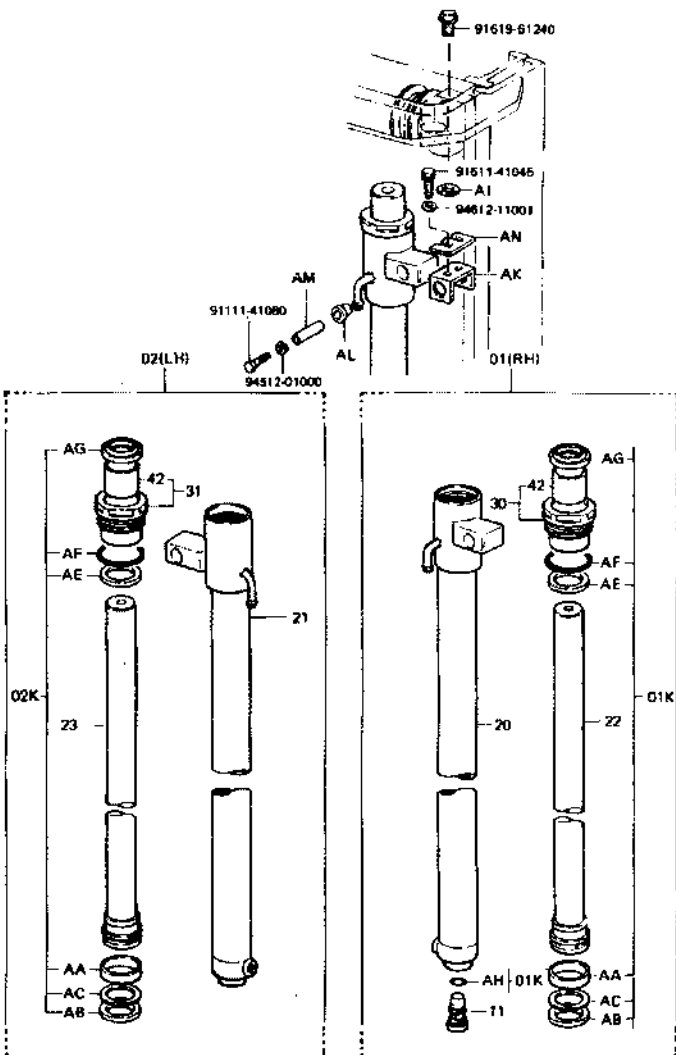

6501-011

PART NAME CODE	PART NAME	QTY
6501-01	CYLINDER ASSY, LIFT, RH	1
6501-01K	CYLINDER O/H KIT, LIFT, RH	1
6501-02	CYLINDER ASSY, LIFT, LH	1
6501-02K	CYLINDER O/H KIT, LIFT, LH	1
6501-11	VALVE ASSY, SAFETY DOWN	1
6501-20	CYLINDER SUB-ASSY, LIFT, RH	1
6501-21	CYLINDER SUB-ASSY, LIFT, LH	1
6501-22	ROD SUB-ASSY, LIFT CYLINDER, RH	1
6501-23	ROD SUB-ASSY, LIFT CYLINDER, LH	1
6501-30	GUIDE SUB-ASSY, LIFT CYLINDER ROD, RH	1
6501-31	GUIDE SUB-ASSY, LIFT CYLINDER ROD, LH	1
6501-42	SLEEVE, LIFT CYLINDER ROD GUIDE	2
6501-AA	RING, WEAR	2
6501-AB	PACKING, U	2
6501-AC	RING, BACK UP	2
6501-AE	PACKING, U	2
6501-AF	RING, O	2
6501-AG	SEAL, DUST	2
6501-AH	RING, O	2
6501-AI	SHIM	99
6501-AK	BRACKET SUB-ASSY, LIFT CYLINDER	2
6501-AL	BUSHING	4
6501-AM	SPACER	2
6501-AN	SHIM	99

(SV) (4)

G210

FIG. 6511 TILT CYLINDER

6511

SV

SV

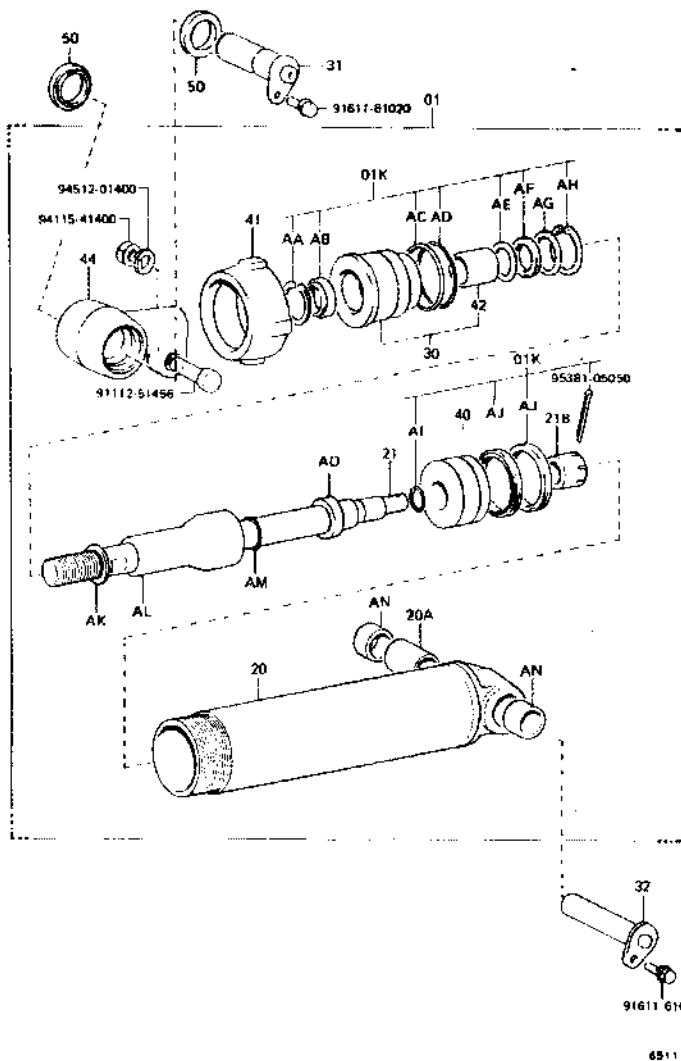

テイルト角度表
TABLE OF TILT RANGE

生産期間 PROD DATE	型式 MODELS	タイヤ TIRE	幅 高 LIFTING HEIGHT	備 考 DESCRIPTION	テイルト角 TILT RANGE
8009-	F, FV, M, SV, V	SINGLE	H2000-H4000		6D - 12D
8009-	F, FV, M, SV, V	DOUBLE	H2000-H4500		8D - 12D
8009-	F, FV, M, SV, V	SINGLE	H4500-H5000		8D - 6D
8009-	F, FV, M, SV, V	DOUBLE	H5000		6D - 8D
8009-	F, FV, M, SV, V		H2000	FRONT GLASS	8D - 10D
8009-	FSV, FS		H3700-H6500		6D - 8D
8009-	F, FV, M, SV, V	SINGLE	H2000-H4000	AUSTRALIA	3D - 12D
8009-	F, FV, M, SV, V	DOUBLE	H2000-H4500	AUSTRALIA	3D - 12D
8009-	F, FV, M, SV, V	SINGLE	H4500-H5000	AUSTRALIA	3D - 6D
8009-	F, FV, M, SV, V	DOUBLE	H5000	AUSTRALIA	3D - 6D
8009-	F, FV, M, SV, V		H2000	FRONT GLASS AUSTRALIA	3D - 10D
8009-	FV, M, SV, V		H3700-H6500	AUSTRALIA	3D - 6D

FIG. 8511 TILT CYLINDER

6511

SV

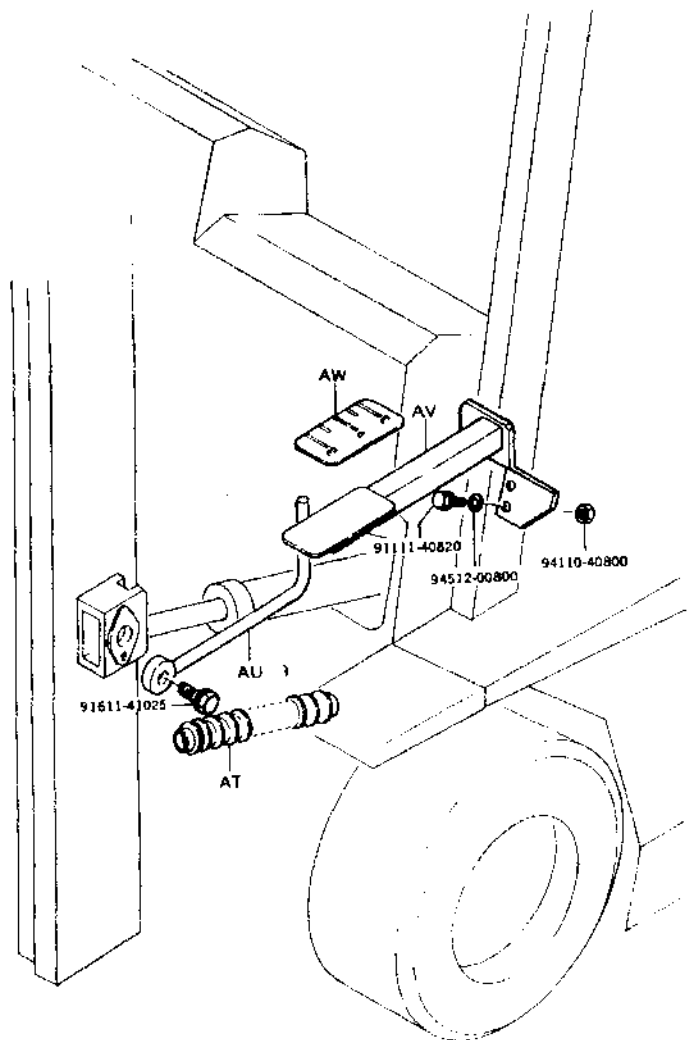

6511-010

PART NAME CODE	PART NAME	QTY
6511-01	CYLINDER ASSY, TILT -----	2
6511-01K	CYLINDER O/H KIT, TILT -----	2
6511-20	CYLINDER SUB-ASSY, TILT -----	2
6511-20A	BUSH, PIN (FOR CYLINDER) -----	2
6511-21	ROD SUB-ASSY, TILT CYLINDER PISTON -----	2
6511-21H	NUT, CASTLE -----	2
6511-30	GUIDE SUB-ASSY, TILT CYLINDER ROD -----	2
6511-31	PIN SUB-ASSY, TILT CYLINDER -----	2
6511-32	PIN SUB-ASSY, TILT CYLINDER, RR -----	2
6511-40	PISTON, TILT CYLINDER -----	2
6511-41	COVER, TILT CYLINDER -----	2
6511-42	SLEEVE, TILT CYLINDER ROD GUIDE -----	2
6511-44	JOINT, PISTON ROD -----	2
6511-50	SEAL, GREASE -----	2
6511-AA	RING, HOLE SNAP -----	2
6511-AB	SEAL, DUST -----	2
6511-AC	RING, BACK UP -----	2
6511-AD	RING, O -----	2
6511-AE	RING, BACK UP -----	2
6511-AF	PACKING, U -----	2
6511-AG	PLATE, STOPPER -----	2
6511-AH	RING, HOLE SNAP -----	2
6511-AI	RING, O -----	2
6511-AJ	PACKING, U -----	4
6511-AK	SHIM, TILT CONTROL -----	99
6511-AL	SPACER, TILT CONTROL -----	2
6511-AM	RING, O -----	4
6511-AN	COLLAR -----	4
6511-AO	SPACER, TILT CONTROL -----	2
6511-AT	BOOT SUB-ASSY -----	2
6511-AU	BAR SUB-ASSY, TILT GAUGE -----	1
6511-AV	BRACKET SUB-ASSY, TILT GAUGE -----	1
6511-AW	PLATE, TILT CYLINDER INDICATOR -----	1

(SV) (5)

G210

FIG. 6701 OIL PUMP

6701

SV

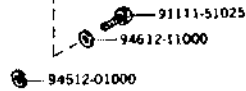
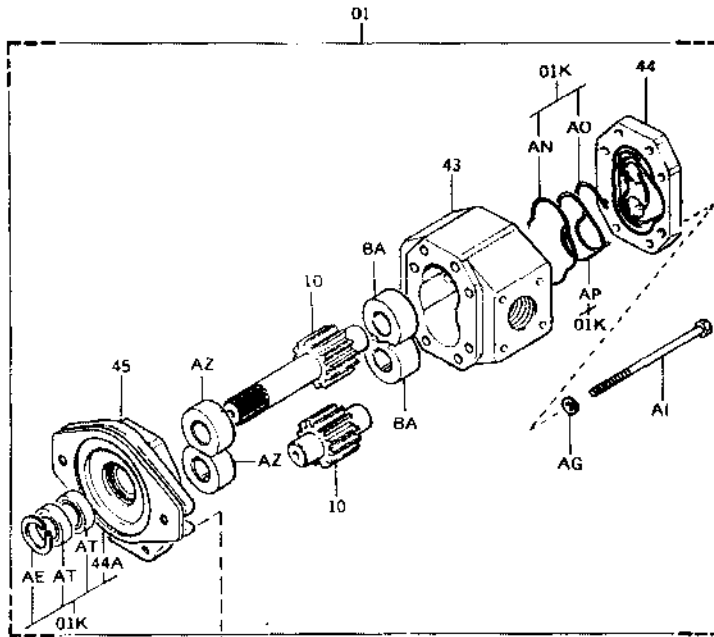

6701-019

PART NAME CODE	PART NAME	QTY
6701-01	PUMP ASSY, OIL -----	1
6701-01K	PUMP O/H KIT, OIL -----	1
6701-10	GEAR SET -----	1
6701-11	BUSH SET, NO.1 -----	2
6701-43	BODY -----	1
6701-44	FLANGE, MOUNTING -----	1
6701-45	COVER -----	1
6701-AA	SEAL, BUSHING -----	2
6701-AB	RING, BACKING, RH -----	2
6701-AC	RING, BACKING, LH -----	2
6701-AD	SEAL, OIL -----	1
6701-AE	RING, SNAP -----	1
6701-AF	BOLT -----	4
6701-AG	WASHER, SPRING -----	4
6701-AH	SEAL, BODY -----	2
6701-AI	BOLT -----	2

(SV) (6)

G210

FIG. 6705 OIL CONTROL VALVE

6705

SV (4-WAY)

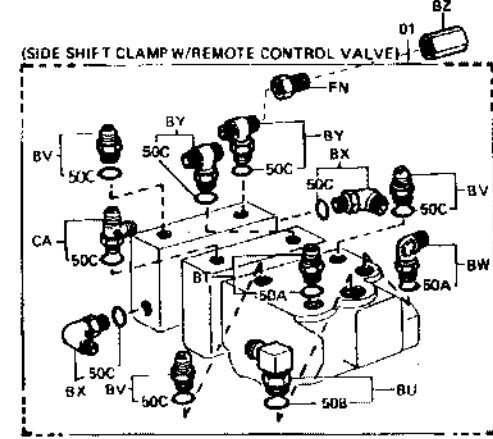
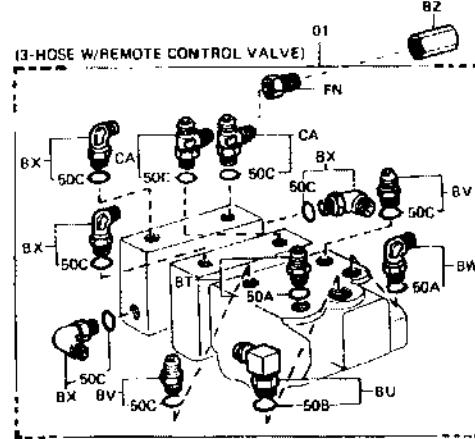
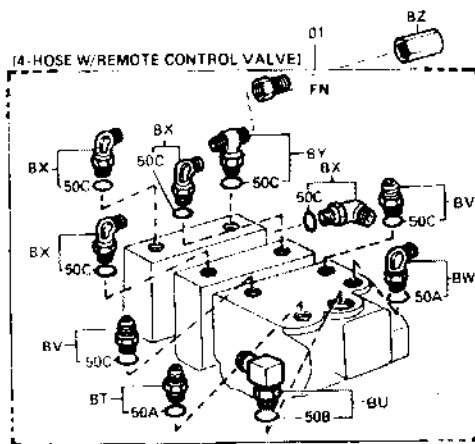
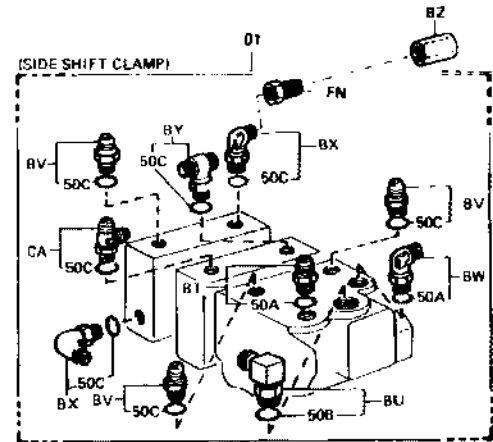
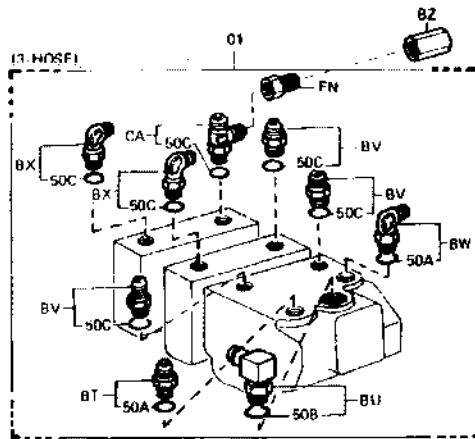
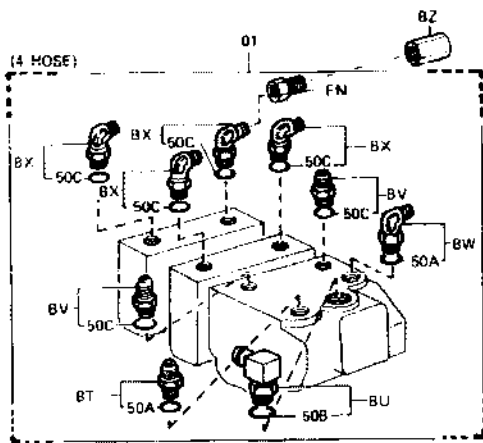

6705-058



FIG. 6705 OIL CONTROL VALVE

6705

SV (4-WAY, 1JL-EE)

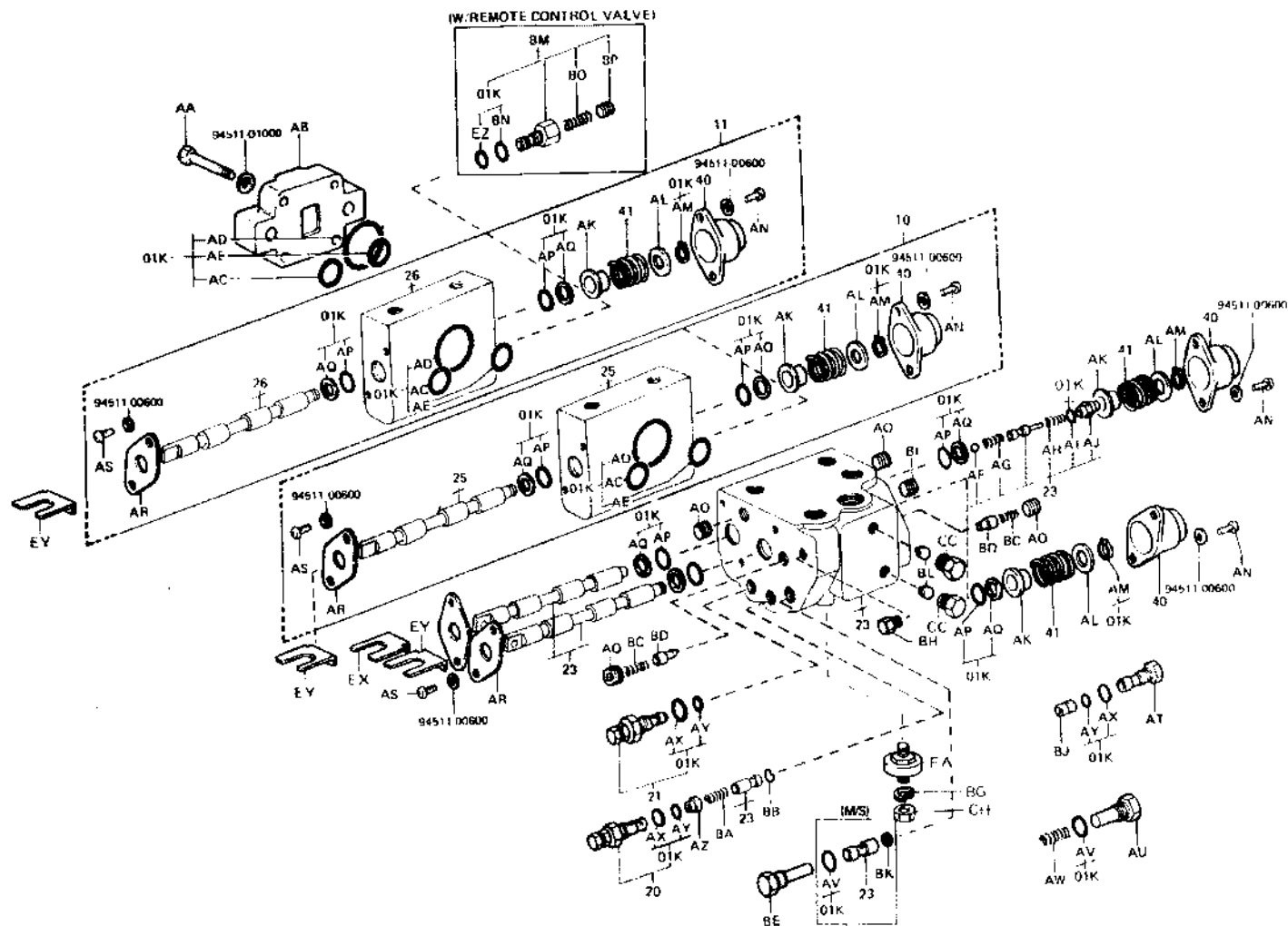

6705 044

FIG. 6705 OIL CONTROL VALVE

6705

SV (4-WAY)

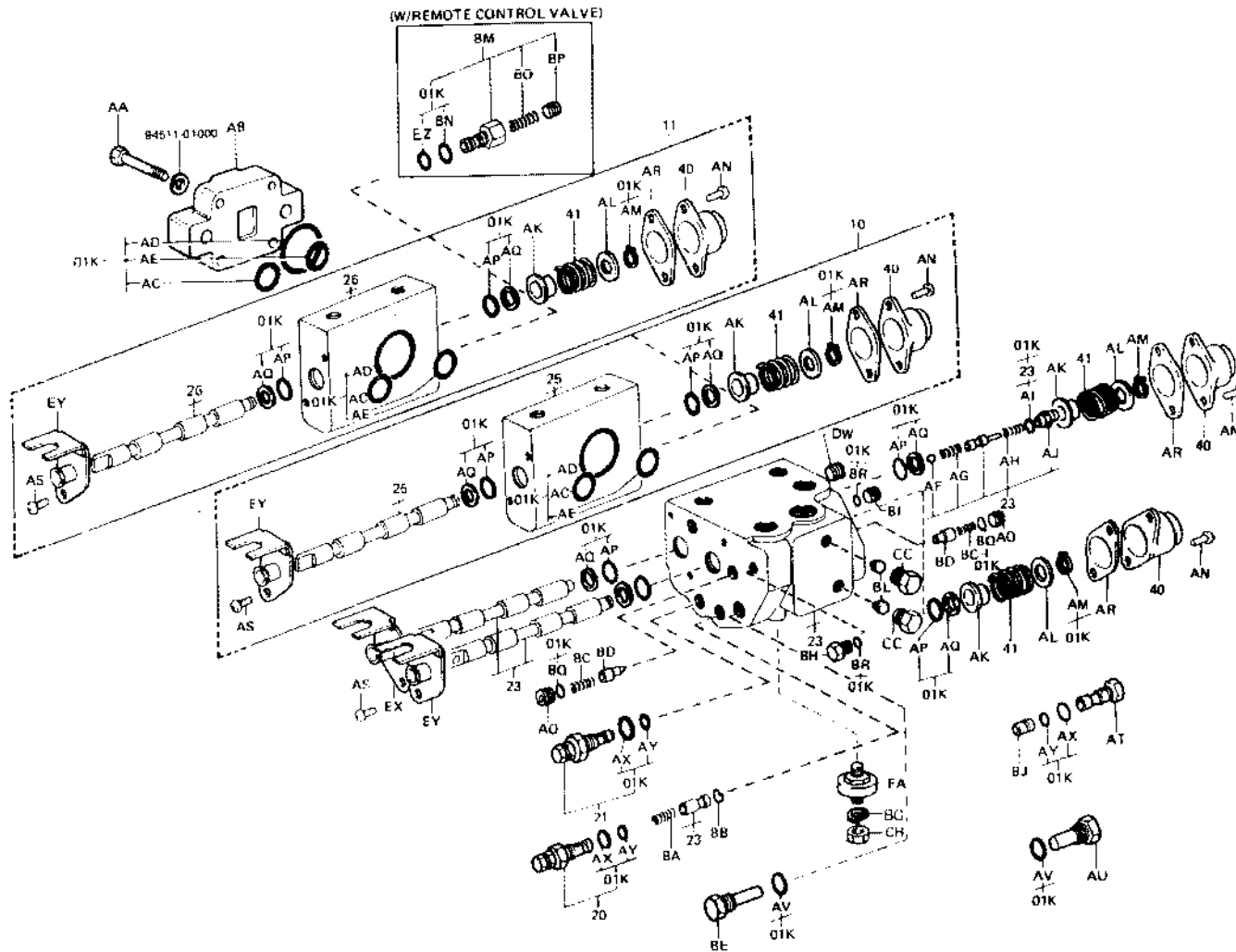

6705

PART NAME CODE	PART NAME	QTY
6705-01	VALVE ASSY, OIL CONTROL -----	1
6705-01K	VALVE O/H KIT, OIL CONTROL -----	1
6705-10	VALVE ASSY, PLUNGER SECTION, NO.1 -----	1
6705-11	VALVE ASSY, PLUNGER SECTION, NO.2 -----	1
6705-20	VALVE SET, PILOT RELIEF, NO.1 -----	1
6705-21	VALVE SET, PILOT RELIEF, NO.2 -----	1
6705-23	HOUSING & SPOOL SET, NO.1 -----	1
6705-25	HOUSING & SPOOL SET, ATTACHMENT, NO.1 -----	1
6705-26	HOUSING & SPOOL SET, ATTACHMENT, NO.2 -----	1
6705-40	COVER, SPRING -----	2
6705-41	SPRING, COMPRESSION (FOR SPOOL RETURN) -----	2
6705-50A	RING, O, NO.1 (FOR VALVE FITTING) -----	2
6705-50B	RING, O, NO.2 (FOR VALVE FITTING) -----	1
6705-50C	RING, O, NO.3 (FOR VALVE FITTING) -----	2
6705-AA	BOLT -----	4
6705-AB	HOUSING, OUTLET -----	1
6705-AC	RING, O -----	1
6705-AD	RING, O -----	1
6705-AE	RING, O -----	1
6705-AF	BALL, STEEL -----	1
6705-AG	SPRING -----	1
6705-AH	SPRING, COMPRESSION -----	1
6705-AI	RING, O -----	1
6705-AJ	STOPPER -----	1
6705-AK	HOLDER, SPRING -----	2
6705-AL	WASHER, PLATE -----	2
6705-AM	RING, SHAFT SNAP -----	2
6705-AN	SCREW -----	4
6705-AO	PLUG -----	2
6705-AP	RING, O -----	4
6705-AQ	RING, BACK UP -----	4
6705-AR	HOLDER, SEAL -----	2
6705-AS	SCREW -----	4
6705-AT	STOPPER -----	1
6705-AU	STOPPER -----	1
6705-AV	RING, O -----	2
6705-AX	RING, O -----	3
6705-AY	RING, O -----	3
6705-BA	SPRING, COMPRESSION -----	1
6705-BB	WIRE, ORIFICE TURNING -----	1
6705-BC	SPRING, COMPRESSION -----	2
6705-BD	PLUNGER, CHECK -----	2
6705-BE	STOPPER -----	1
6705-BG	WASHER -----	4
6705-BH	PLUG -----	1
6705-BI	PLUG -----	1
6705-BJ	SEAT, VALVE -----	1
6705-BL	SEAT, INSERT -----	2
6705-BM	VALVE SUB-ASSY, RELIEF -----	1
6705-BN	RING, O -----	1
6705-BO	SPRING -----	1
6705-BP	STOPPER -----	1
6705-BQ	RING, O -----	2

(SV) (7) G210

PART NAME CODE	PART NAME	QTY
6705-BR	RING, O -----	2
6705-BT	FITTING -----	1
6705-BU	FITTING -----	1
6705-BV	FITTING -----	2
6705-BW	FITTING -----	1
6705-BX	FITTING -----	2
6705-BY	FITTING -----	1
6705-BZ	PLUG -----	2
6705-CA	FITTING -----	1
6705-CC	PLUG -----	2
6705-CH	NUT -----	4
6705-CM	PLUG -----	1
6705-EX	BRACKET SUB-ASSY, TILT -----	1
6705-EY	BRACKET SUB-ASSY, LIFT -----	1
6705-EZ	RING, O -----	1
6705-FA	INSULATOR -----	4
6705-FN	FITTING -----	2

(SV) (8) G210

FIG. 6709 OIL CONTROL VALVE LINK

6709

SV

SV (3-WAY)

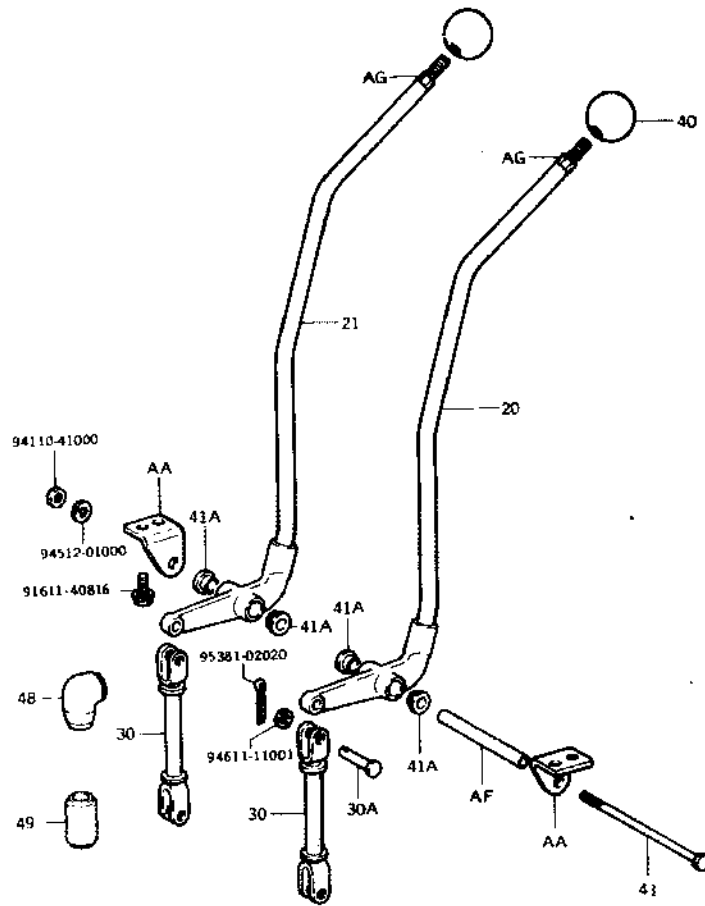

6709 014

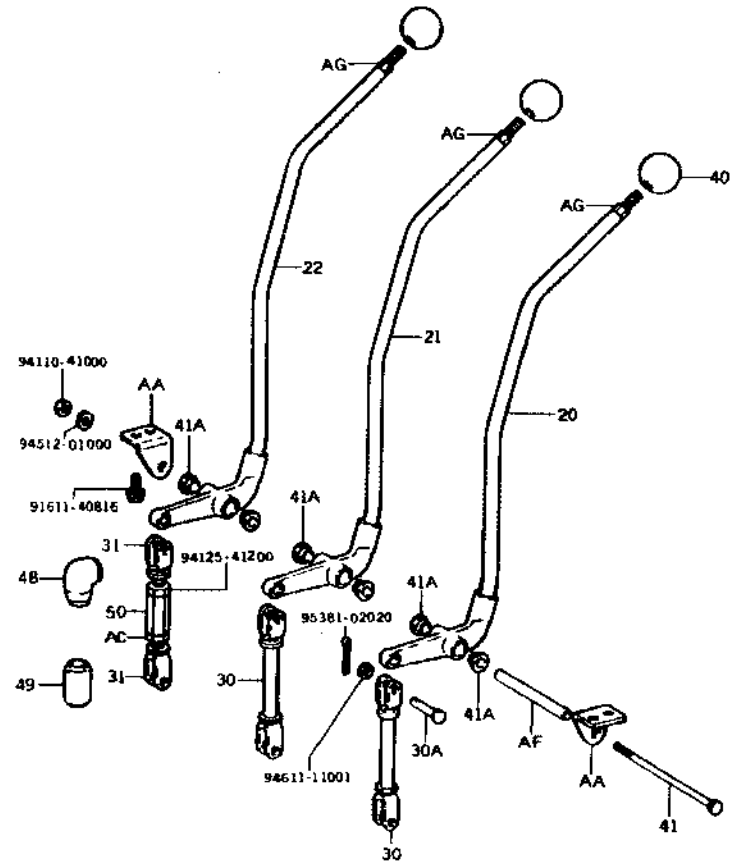

6709-011

FIG. 6709 OIL CONTROL VALVE LINK

6709

SV (4-WAY)

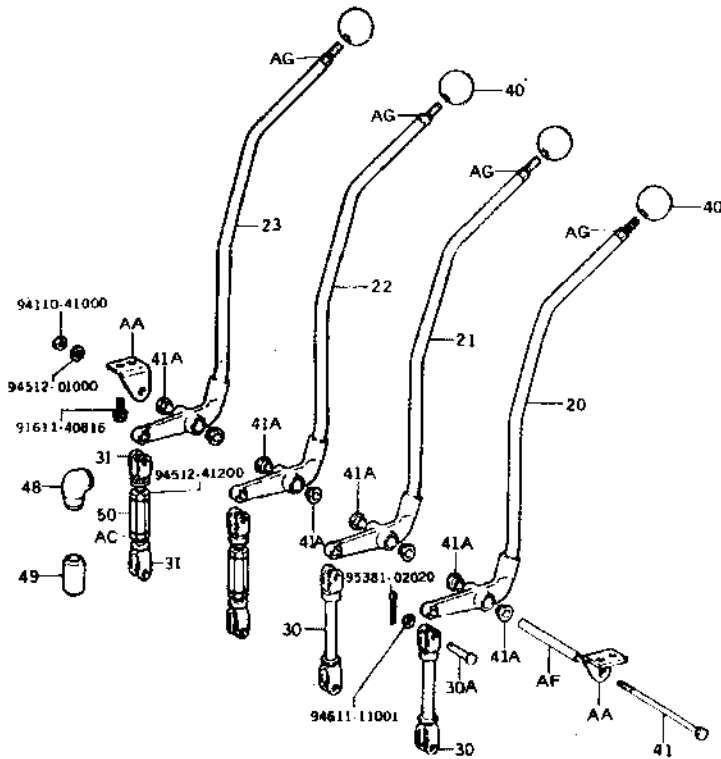

6709 019

PART NAME CODE	PART NAME	QTY
6709-20	LEVER SUB-ASSY, CONTROL VALVE, NO.1	1
6709-21	LEVER SUB-ASSY, CONTROL VALVE, NO.2	1
6709-22	LEVER SUB-ASSY, CONTROL VALVE, NO.3	1
6709-23	LEVER SUB-ASSY, CONTROL VALVE, NO.4	1
6709-30	ROD SUB-ASSY, CONTROL VALVE LEVER, NO.1	2
6709-30A	PIN (FOR CONTROL VALVE LEVER ROD)	4
6709-31	ROD SUB-ASSY, CONTROL VALVE LEVER, NO.2	1
6709-40	KNOB, OIL CONTROL VALVE LEVER	2
6709-41	PIN, OIL CONTROL VALVE LEVER	1
6709-41A	BUSH (FOR LEVER PIN)	4
6709-48	BOOT, CONTROL VALVE LINK, NO.1	2
6709-49	BOOT, CONTROL VALVE LINK, NO.2	2
6709-50	TURNBUCKLE	1
6709-AA	BRACKET SUB-ASSY	1
6709-AC	NUT	1
6709-AF	SPACER	1
6709-AG	BOLT, STUD	2

(SV) (9) G210

6801

PART NAME CODE	PART NAME	QTY
6801-BV	FLANGE -----	2

(SV) (11)

G210

FIG. 6101 MAST

6101

V

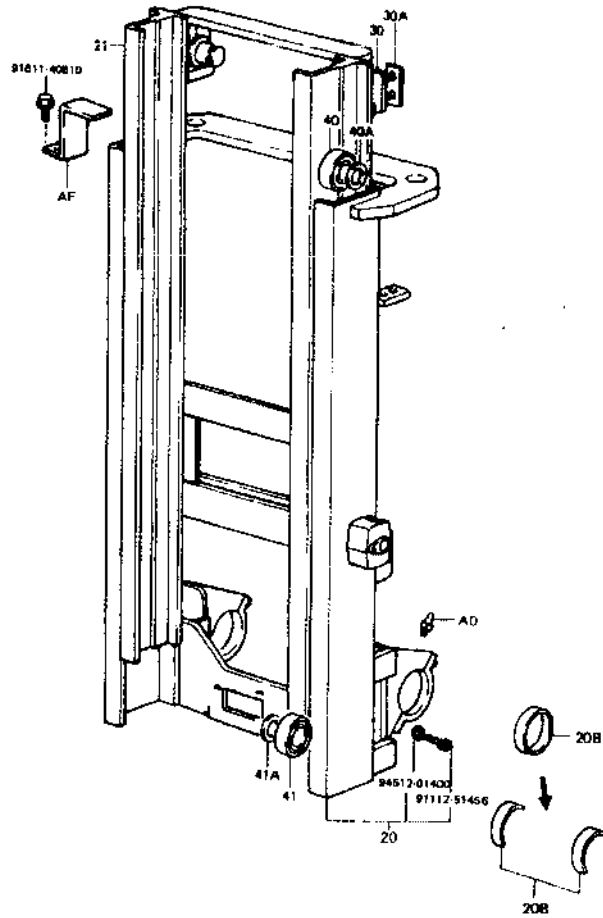

6101-049

PART NAME CODE	PART NAME	QTY
6101-20	MAST SUB-ASSY, OUTER -----	1
6101-20B	BUSH, MAST SUPPORT -----	1
6101-21	MAST SUB-ASSY, INNER -----	1
6101-30	STRIP SUB-ASSY, OUTER MAST -----	2
6101-30A	SHIM, OUTER MAST STRIP -----	99
6101-40	ROLLER, LIFT (FOR OUTER MAST) -----	2
6101-40A	SHIM, LIFT ROLLER (FOR OUTER MAST) -----	99
6101-41	ROLLER, LIFT (FOR INNER MAST) -----	2
6101-41A	SHIM, LIFT ROLLER (FOR INNER MAST) -----	99
6101-AD	FITTING, GREASE -----	2
6101-AF	COVER, ROLLER -----	1

(V) (1)

G210

FIG. 6301 LIFT BRACKET & FORK

6301

V

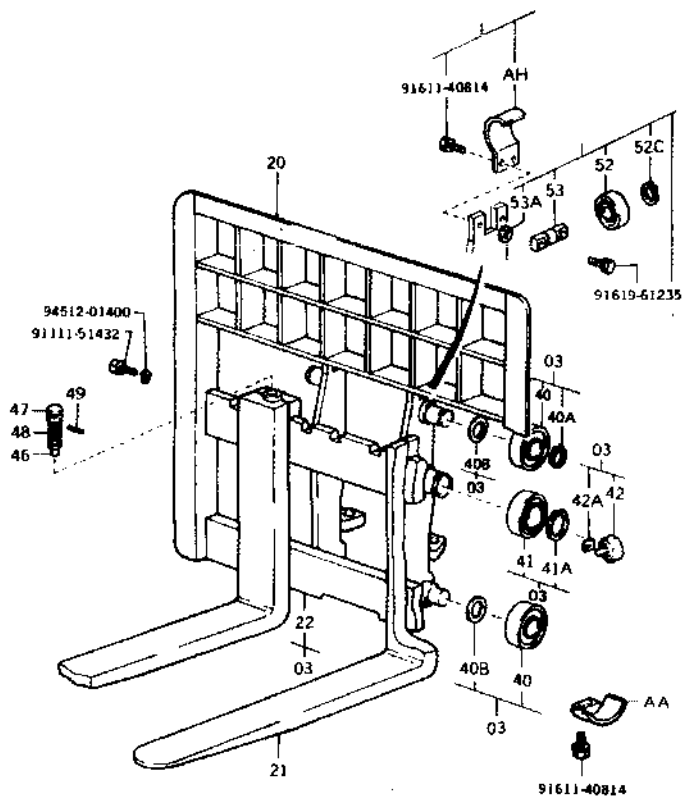

6301-028A

PART NAME CODE	PART NAME	QTY
6301-03	BRACKET ASSY, LIFT -----	1
6301-20	BACKREST SUB-ASSY -----	1
6301-21	FORK SUB-ASSY -----	2
6301-22	BRACKET SUB-ASSY, LIFT -----	1
6301-40	ROLLER, LIFT (UPPER, LOWER) -----	4
6301-40A	RING, SHAFT SNAP (UPPER, LOWER) -----	2
6301-40B	SHIM, LIFT ROLLER -----	99
6301-41	ROLLER, LIFT (CENTER) -----	2
6301-41A	RING, SHAFT SNAP (CENTER) -----	2
6301-42	ROLLER, SIDE -----	2
6301-42A	SHIM (FOR SIDE ROLLER) -----	99
6301-46	PIN, FORK STOPPER -----	2
6301-47	KNOB, FORK STOPPER PIN -----	2
6301-48	SPRING, FORK STOPPER PIN -----	2
6301-49	PIN, SPRING (FOR FORK STOPPER PIN) -----	2
6301-52	ROLLER, SIDE, NO.2 -----	2
6301-52C	RING, SHAFT SNAP (FOR SIDE ROLLER) -----	4
6301-53	PIN, SIDE ROLLER -----	2
6301-53A	SHIM (FOR SIDE ROLLER PIN) -----	99
6301-AA	COVER, LIFT BRACKET ROLLER -----	2
6301-AH	COVER, LIFT BRACKET, SIDE ROLLER -----	2

FIG. 6302 CHAIN & CHAIN WHEEL

6302

V

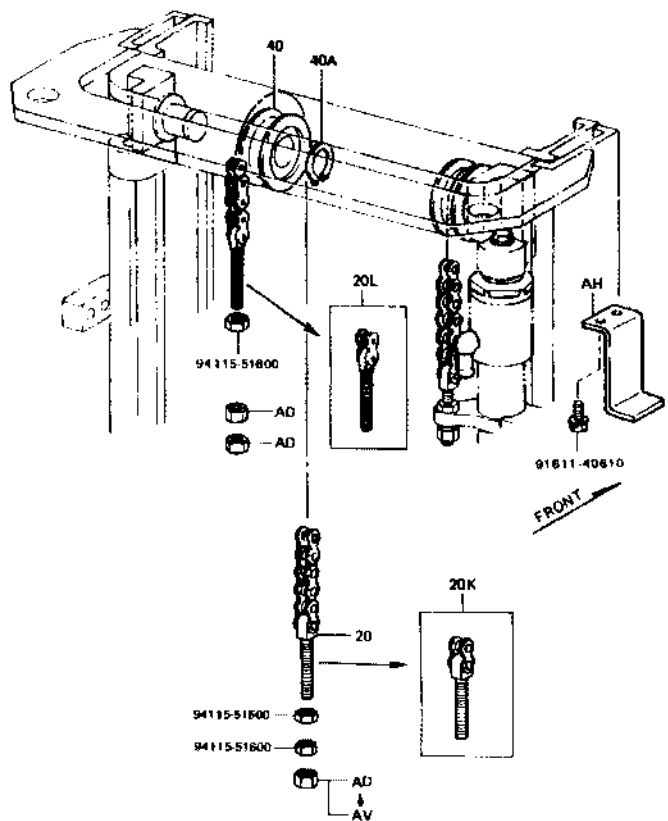

6302-0006

PART NAME	QTY
6302-20 CHAIN SUB-ASSY	2
6302-20K BOLT KIT, CHAIN ANCHOR, NO.1	2
6302-20L BOLT KIT, CHAIN ANCHOR, NO.2	2
6302-40 WHEEL, CHAIN	2
6302-40A RING, SHAFT SNAP (FOR CHAIN WHEEL)	2
6302-AD NUT, HEXAGON	4
6302-AH COVER, CHAIN WHEEL	2
6302-AV NUT, LOCK	2

FIG 6501 LIFT CYLINDER

6501

V

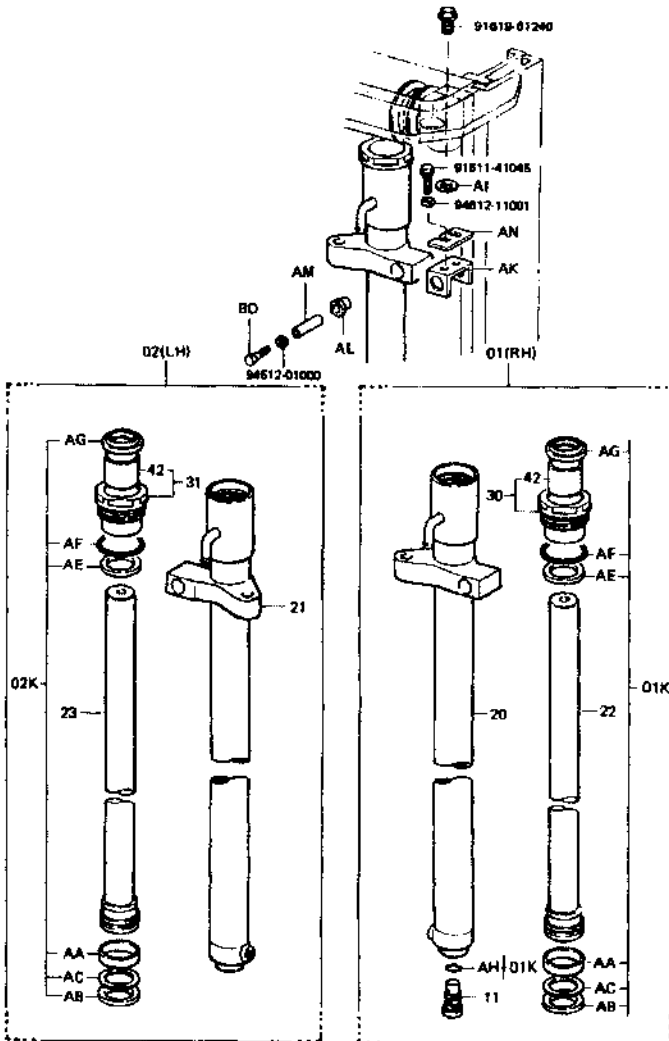

PART NAME CODE	PART NAME	QTY
6501-01	CYLINDER ASSY, LIFT, RH	1
6501-01K	CYLINDER O/H KIT, LIFT, RH	1
6501-02	CYLINDER ASSY, LIFT, LH	1
6501-02K	CYLINDER O/H KIT, LIFT, LH	1
6501-11	VALVE ASSY, SAFETY DOWN	1
6501-20	CYLINDER SUB-ASSY, LIFT, RH	1
6501-21	CYLINDER SUB-ASSY, LIFT, LH	1
6501-22	ROD SUB-ASSY, LIFT CYLINDER, RH	1
6501-23	ROD SUB-ASSY, LIFT CYLINDER, LH	1
6501-30	GUIDE SUB-ASSY, LIFT CYLINDER ROD, RH	1
6501-31	GUIDE SUB-ASSY, LIFT CYLINDER ROD, LH	1
6501-42	SLEEVE, LIFT CYLINDER ROD GUIDE	2
6501-AA	RING, WEAR	2
6501-AB	PACKING, U	2
6501-AC	RING, BACK UP	2
6501-AE	PACKING, U	2
6501-AF	RING, O	2
6501-AG	SEAL, DUST	2
6501-AH	RING, O	2
6501-AI	SHIM	99
6501-AK	BRACKET SUB-ASSY, LIFT CYLINDER	2
6501-AL	BUSHING	4
6501-AM	SPACER	2
6501-AN	SHIM	99
6501-AQ	RING, O	2
6501-AT	PLUG	2
6501-BD	BOLT	2

(V) (4)

G210

FIG. 6511 CYLINDER

6511

V

V

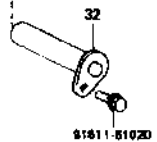
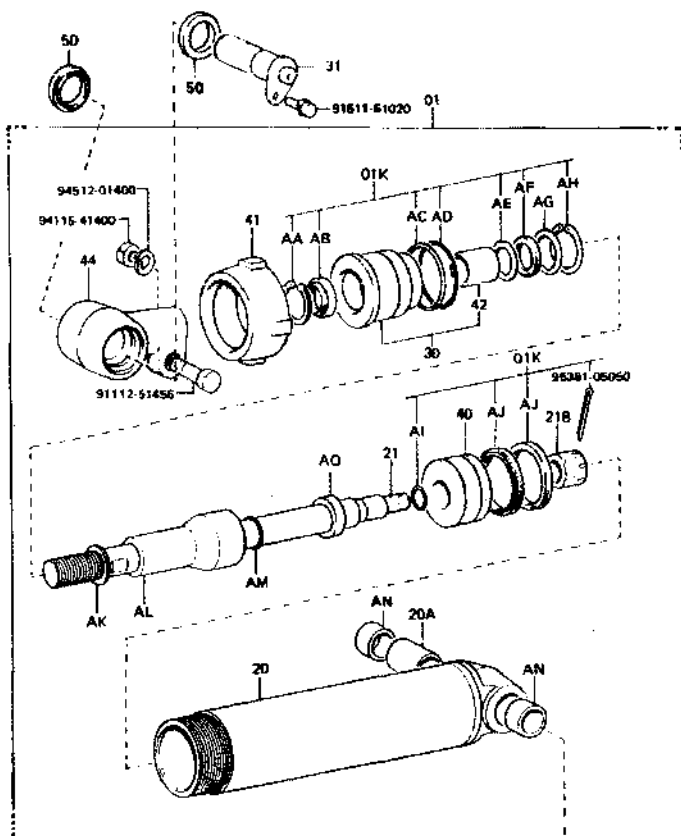

8511 010

テイルト角度表
TABLE OF TILT RANGE

生産期間 PROD DATE	型式 MODELS	タイヤ TIRE	繰高 LIFTING HEIGHT	備考 DESCRIPTION	テイルト角 TILT RANGE
8009-	F, FV, M, SV, V	SINGLE	H2000-H4000		6D-12D
8009-	F, FV, M, SV, V	DOUBLE	H2000-H4500		6D-12D
8009-	F, FV, M, SV, V	SINGLE	H4500-H5000		6D-6D
8009-	F, FV, M, SV, V	DOUBLE	H5000		6D-6D
8009-	F, FV, M, SV, V		H2000	FRONT GLASS	6D-10D
8009-	FSV, FS		H3700-H6500		6D-6D
8009-	F, FV, M, SV, V	SINGLE	H2000-H4000	AUSTRALIA	3D-12D
8009-	F, FV, M, SV, V	DOUBLE	H2000-H4500	AUSTRALIA	3D-12D
8009-	F, FV, M, SV, V	SINGLE	H4500-H5000	AUSTRALIA	3D-6D
8009-	F, FV, M, SV, V	DOUBLE	H5000	AUSTRALIA	3B-6D
8009-	F, FV, M, SV, V		H2000	FRONT GLASS AUSTRALIA	3D-10D
8009-	FV, M, SV, V		H3700-H6500	AUSTRALIA	3D-6D

FIG 6511 CYLINDER

6511

V

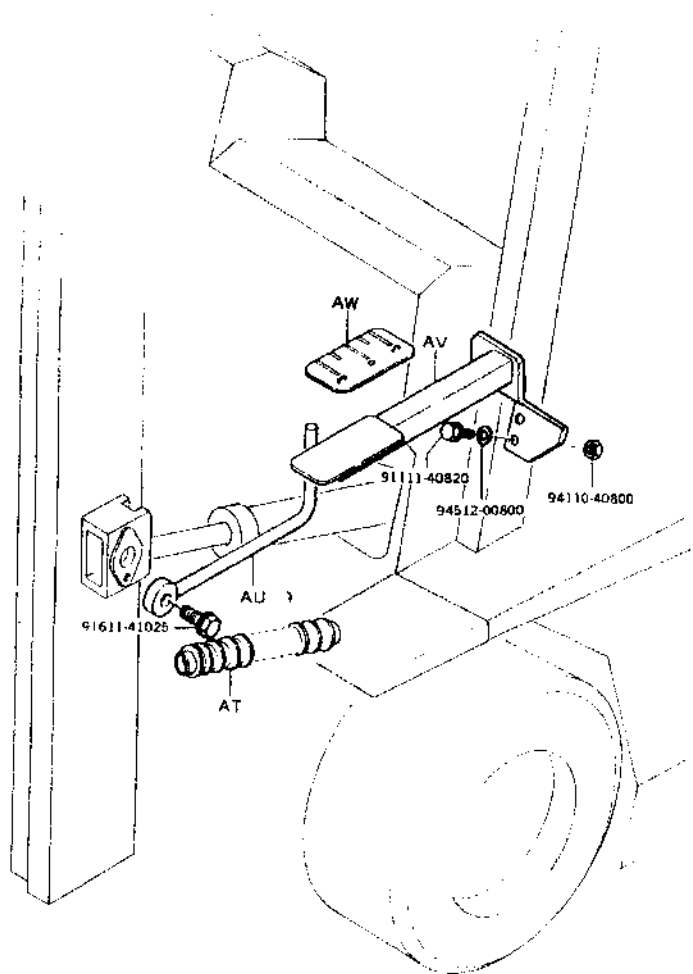

6511 013

PART NAME CODE	PART NAME	QTY
6511-01	CYLINDER ASSY, TILT -----	2
6511-01K	CYLINDER O/H KIT, TILT -----	2
6511-20	CYLINDER SUB-ASSY, TILT -----	2
6511-20A	BUSH, PIN (FOR CYLINDER) -----	2
6511-21	ROD SUB-ASSY, TILT CYLINDER PISTON -----	2
6511-218	NUT, CASTLE -----	2
6511-30	GUIDE SUB-ASSY, TILT CYLINDER ROD -----	2
6511-31	PIN SUB-ASSY, TILT CYLINDER -----	2
6511-32	PIN SUB-ASSY, TILT CYLINDER, RR -----	2
6511-40	PISTON, TILT CYLINDER -----	2
6511-41	COVER, TILT CYLINDER -----	2
6511-42	SLEEVE, TILT CYLINDER ROD GUIDE -----	2
6511-44	JOINT, PISTON ROD -----	2
6511-50	SEAL, GREASE -----	2
6511-AA	RING, HOLE SNAP -----	2
6511-AB	SEAL, DUST -----	2
6511-AC	RING, BACK UP -----	2
6511-AD	RING, O -----	2
6511-AE	RING, BACK UP -----	2
6511-AF	PACKING, U -----	2
6511-AG	PLATE, STOPPER -----	2
6511-AH	RING, HOLE SNAP -----	2
6511-AI	RING, O -----	2
6511-AJ	PACKING, U -----	4
6511-AK	SHIM, TILT CONTROL -----	99
6511-AL	SPACER, TILT CONTROL -----	2
6511-AM	RING, O -----	4
6511-AN	COLLAR -----	4
6511-AO	SPACER, TILT CONTROL -----	2
6511-AT	BOOT SUB-ASSY -----	2
6511-AU	BAR SUB-ASSY, TILT GAUGE -----	1
6511-AV	BRACKET SUB-ASSY, TILT GAUGE -----	1
6511-AW	PLATE, TILT CYLINDER INDICATOR -----	1

(V) (5)

G210

FIG. 6701 OIL PUMP

6701

V

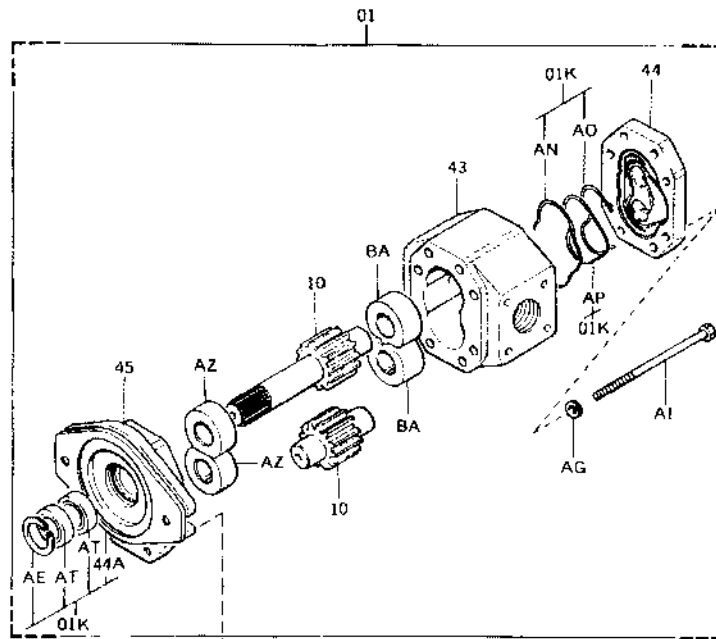

PART NAME CODE	PART NAME	QTY
6701-01	PUMP ASSY, OIL	1
6701-01K	PUMP O/H KIT, OIL	1
6701-10	GEAR SET	1
6701-11	BUSH SET, NO.1	2
6701-43	BODY	1
6701-44	FLANGE, MOUNTING	1
6701-45	COVER	1
6701-AA	SEAL, BUSHING	2
6701-AB	RING, BACKING, RH	2
6701-AC	RING, BACKING, LH	2
6701-AD	SEAL, OIL	1
6701-AE	RING, SNAP	1
6701-AF	BOLT	4
6701-AG	WASHER, SPRING	4
6701-AH	SEAL, BODY	2
6701-AI	BOLT	2

6701-018

FIG. 6705 OIL CONTROL VALVE

6705

V

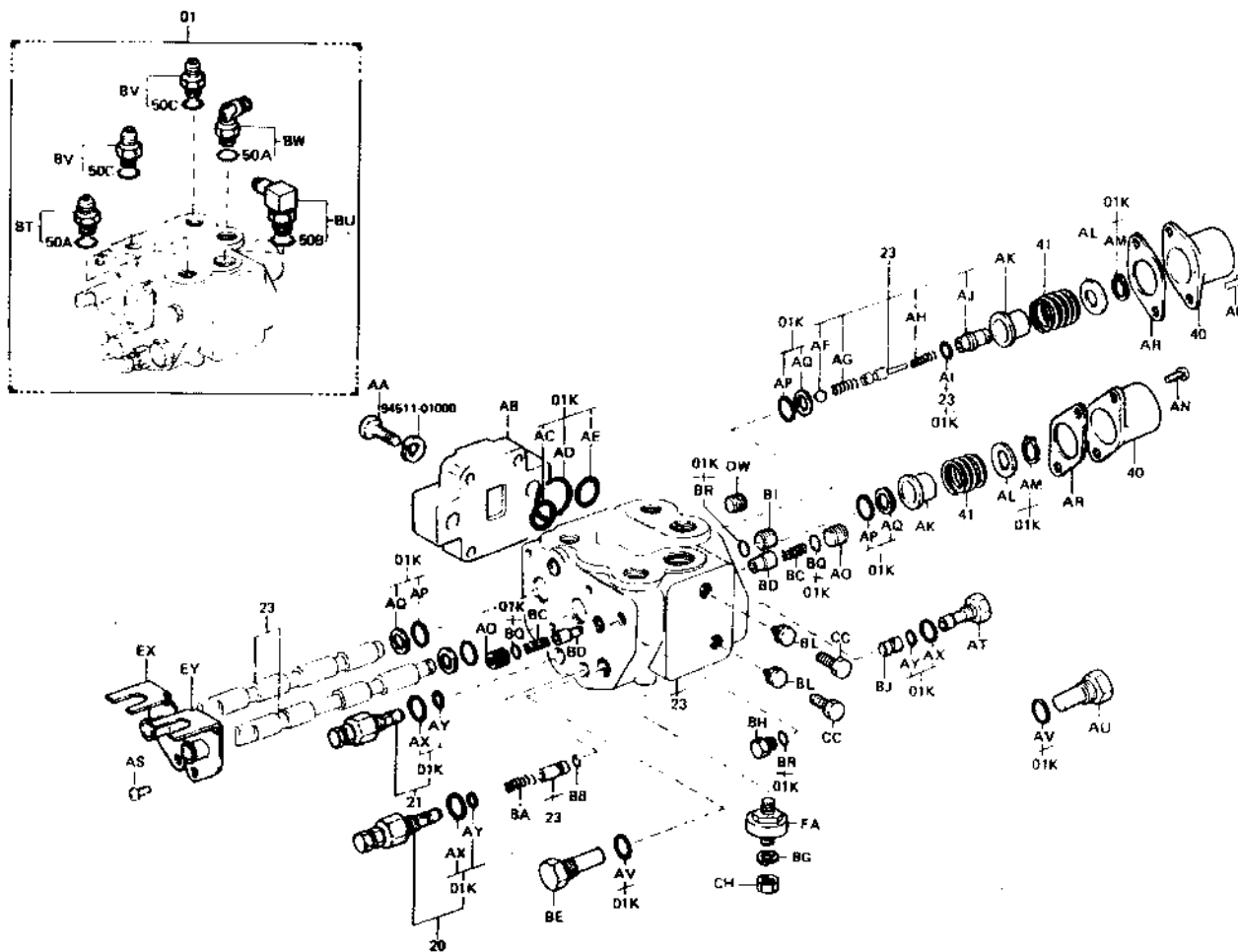

6705-056



FIG. 6705 OIL CONTROL VALVE

6705

V (4-WAY)

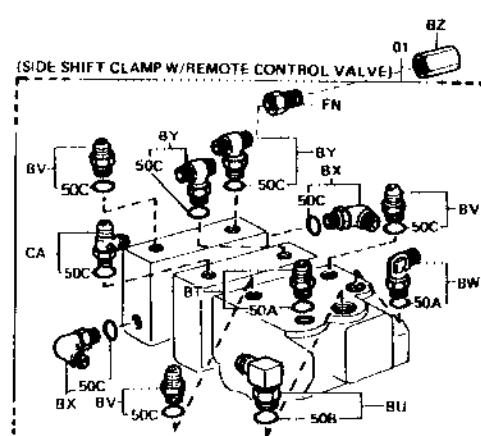
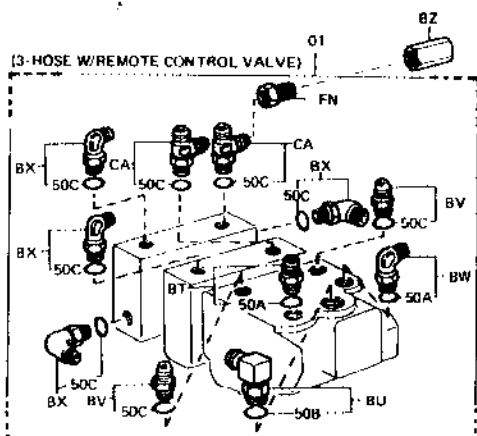
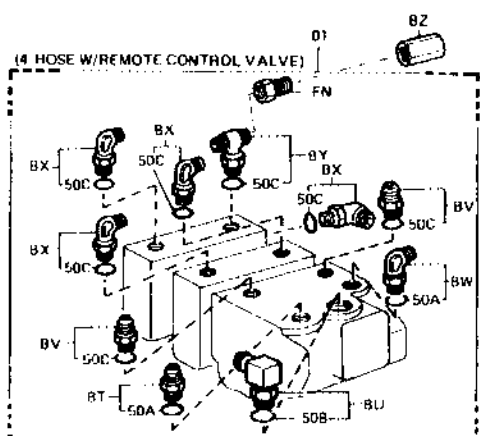
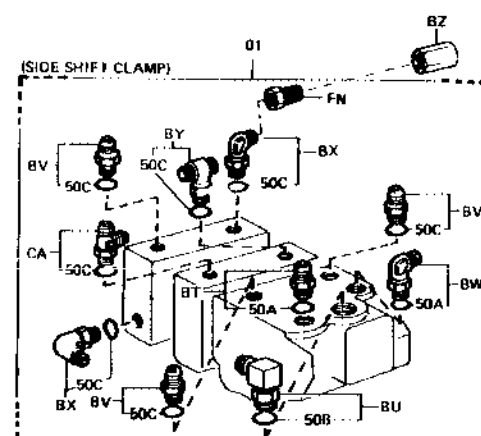
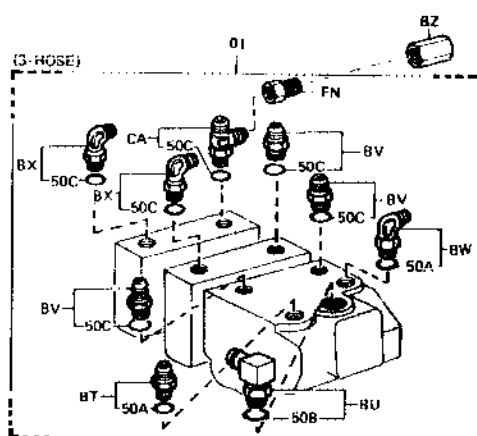
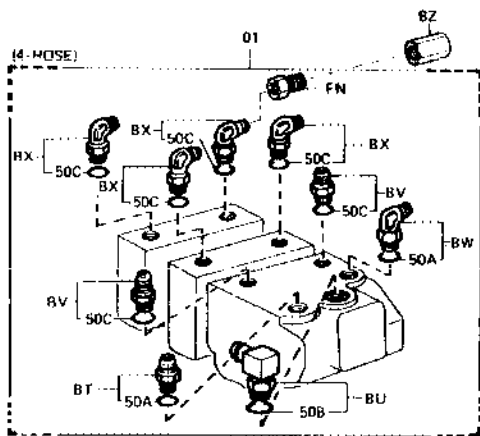
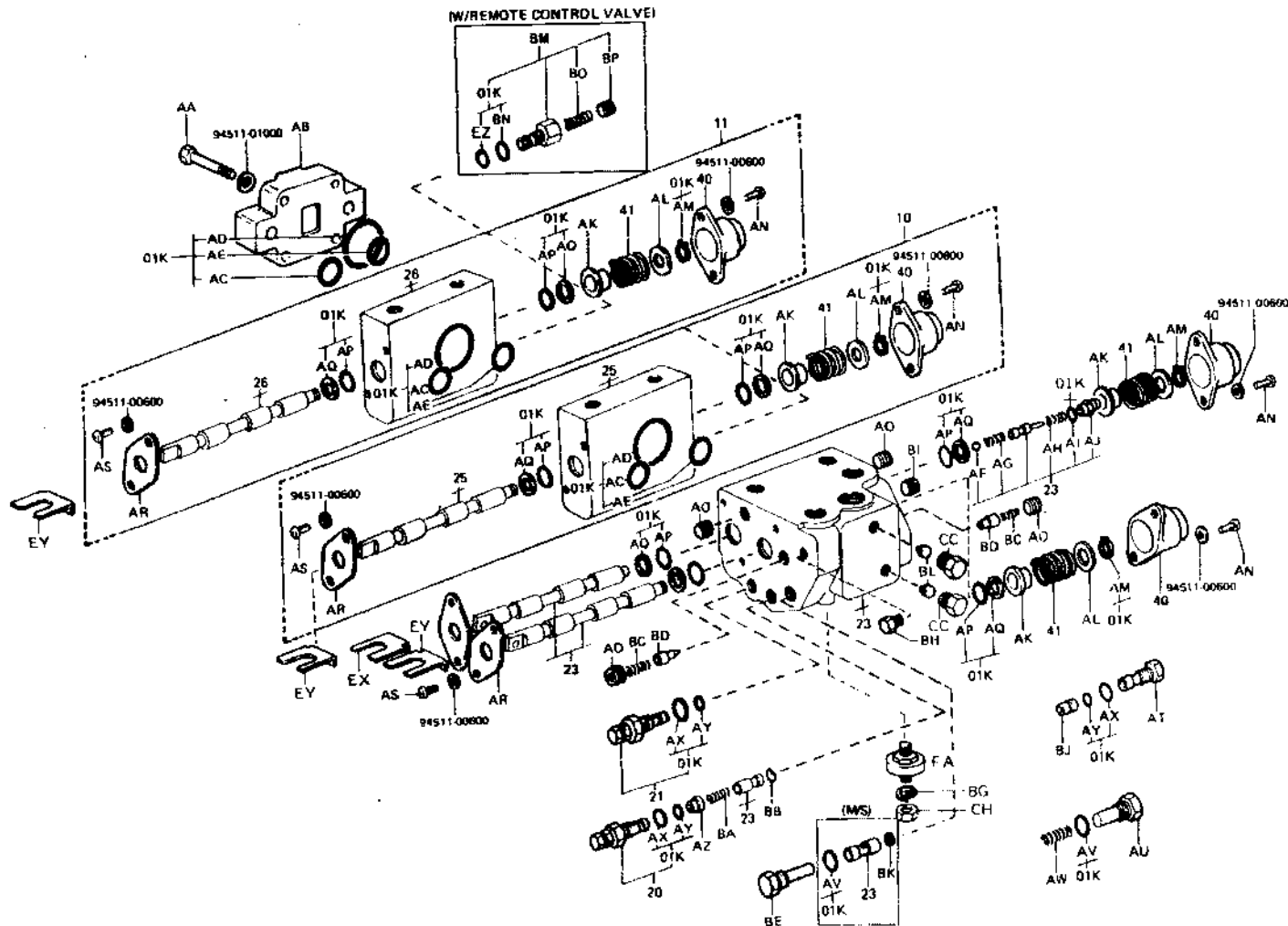

FIG. 6705 OIL CONTROL VALVE

6705

V (4-WAY..UL-EE)



6705

PART NAME CODE	PART NAME	QTY
6705-01	VALVE ASSY, OIL CONTROL	1
6705-01K	VALVE O/H KIT, OIL CONTROL	1
6705-10	VALVE ASSY, PLUNGER SECTION, NO.1	1
6705-11	VALVE ASSY, PLUNGER SECTION, NO.2	1
6705-20	VALVE SET, PILOT RELIEF, NO.1	1
6705-21	VALVE SET, PILOT RELIEF, NO.2	1
6705-23	HOUSING & SPOOL SET, NO.1	1
6705-25	HOUSING & SPOOL SET, ATTACHMENT, NO.1	1
6705-26	HOUSING & SPOOL SET, ATTACHMENT, NO.2	1
6705-40	COVER, SPRING	2
6705-41	SPRING, COMPRESSION (FOR SPOOL RETURN)	2
6705-50A	RING, O, NO.1 (FOR VALVE FITTING)	2
6705-50B	RING, O, NO.2 (FOR VALVE FITTING)	1
6705-50C	RING, O, NO.3 (FOR VALVE FITTING)	2
6705-AA	BOLT	4
6705-AB	HOUSING, OUTLET	1
6705-AC	RING, O	1
6705-AD	RING, O	1
6705-AE	RING, O	1
6705-AF	BALL, STEEL	1
6705-AG	SPRING	1
6705-AH	SPRING, COMPRESSION	1
6705-AI	RING, O	1
6705-AJ	STOPPER	1
6705-AK	HOLDER, SPRING	2
6705-AL	WASHER, PLATE	2
6705-AM	RING, SHAFT SNAP	2
6705-AN	SCREW	4
6705-AO	PLUG	2
6705-AP	RING, O	4
6705-AQ	RING, BACK UP	4
6705-AR	HOLDER, SEAL	2
6705-AS	SCREW	4
6705-AT	STOPPER	1
6705-AU	STOPPER	1
6705-AV	RING, O	2
6705-AX	RING, O	3
6705-AY	RING, O	3
6705-BA	SPRING, COMPRESSION	1
6705-BB	WIRE, ORIFICE TURNING	1
6705-BC	SPRING, COMPRESSION	2
6705-BO	PLUNGER, CHECK	2
6705-BE	STOPPER	1
6705-BG	WASHER	4
6705-BH	PLUG	1
6705-BI	PLUG	1
6705-BJ	SEAT, VALVE	1
6705-BL	SEAT, INSERT	2
6705-BM	VALVE SUB-ASSY, RELIEF	1
6705-BN	RING, O	1
6705-BO	SPRING	1
6705-BP	STOPPER	1
6705-BQ	RING, O	2

(V) (7) G210

PART NAME CODE	PART NAME	QTY
6705-BR	RING, O	2
6705-BT	FITTING	1
6705-BU	FITTING	1
6705-BV	FITTING	2
6705-BW	FITTING	1
6705-BX	FITTING	2
6705-BY	FITTING	1
6705-BZ	PLUG	2
6705-CA	FITTING	1
6705-CC	PLUG	2
6705-CH	NUT	4
6705-DW	PLUG	1
6705-EX	BRACKET SUB-ASSY, TILT	1
6705-EY	BRACKET SUB-ASSY, LIFT	1
6705-EZ	RING, O	1
6705-FA	INSULATOR	4
6705-FN	FITTING	2

(V) (8) G210

FIG. 6709 OIL CONTROL VALVE LINK

6709

V

V (3-WAY)

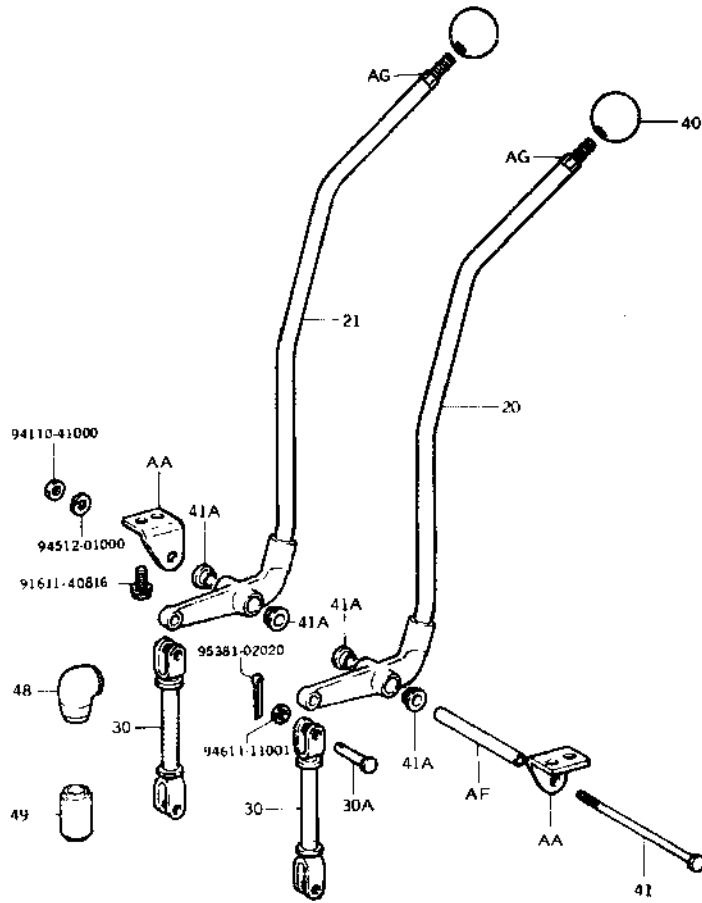

6709-016

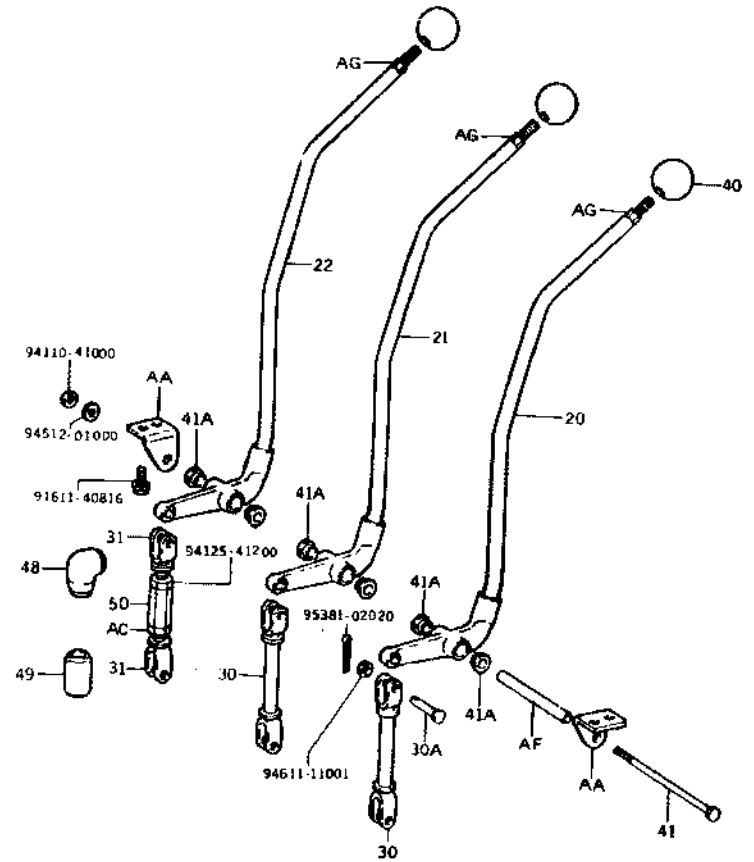

6709-017

FIG. 6709 OIL CONTROL VALVE LINK

6709

V (4-WAY)

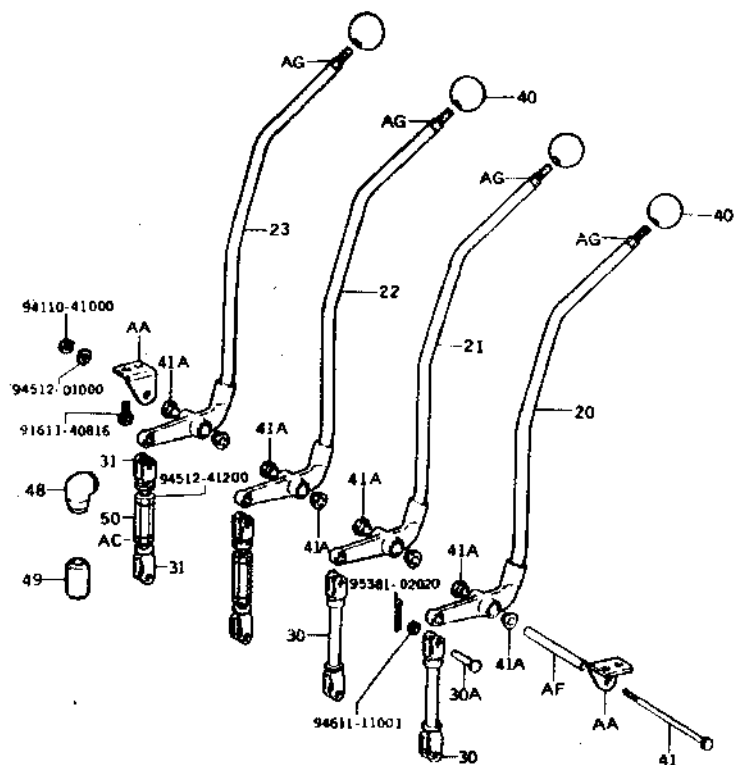

6709-018

PART NAME CODE	PART NAME	QTY
6709-20	LEVER SUB-ASSY, CONTROL VALVE, NO.1	1
6709-21	LEVER SUB-ASSY, CONTROL VALVE, NO.2	1
6709-22	LEVER SUB-ASSY, CONTROL VALVE, NO.3	1
6709-23	LEVER SUB-ASSY, CONTROL VALVE, NO.4	1
6709-30	ROD SUB-ASSY, CONTROL VALVE LEVER, NO.1	2
6709-30A	PIN (FOR CONTROL VALVE LEVER ROD)	4
6709-31	ROD SUB-ASSY, CONTROL VALVE LEVER, NO.2	1
6709-40	KNDB, OIL CONTROL VALVE LEVER	2
6709-41	PIN, OIL CONTROL VALVE LEVER	1
6709-41A	BUSH (FOR LEVER PIN)	4
6709-48	BOOT, CONTROL VALVE LINK, NO.1	2
6709-49	BOOT, CONTROL VALVE LINK, NO.2	2
6709-50	TURNBUCKLE	1
6709-AA	BRACKET SUB-ASSY	1
6709-AC	NUT	1
6709-AF	SPACER	1
6709-AG	BOLT, STUD	2

(V) (9)

G210

FIG. 8801 BODY PIPING

6801

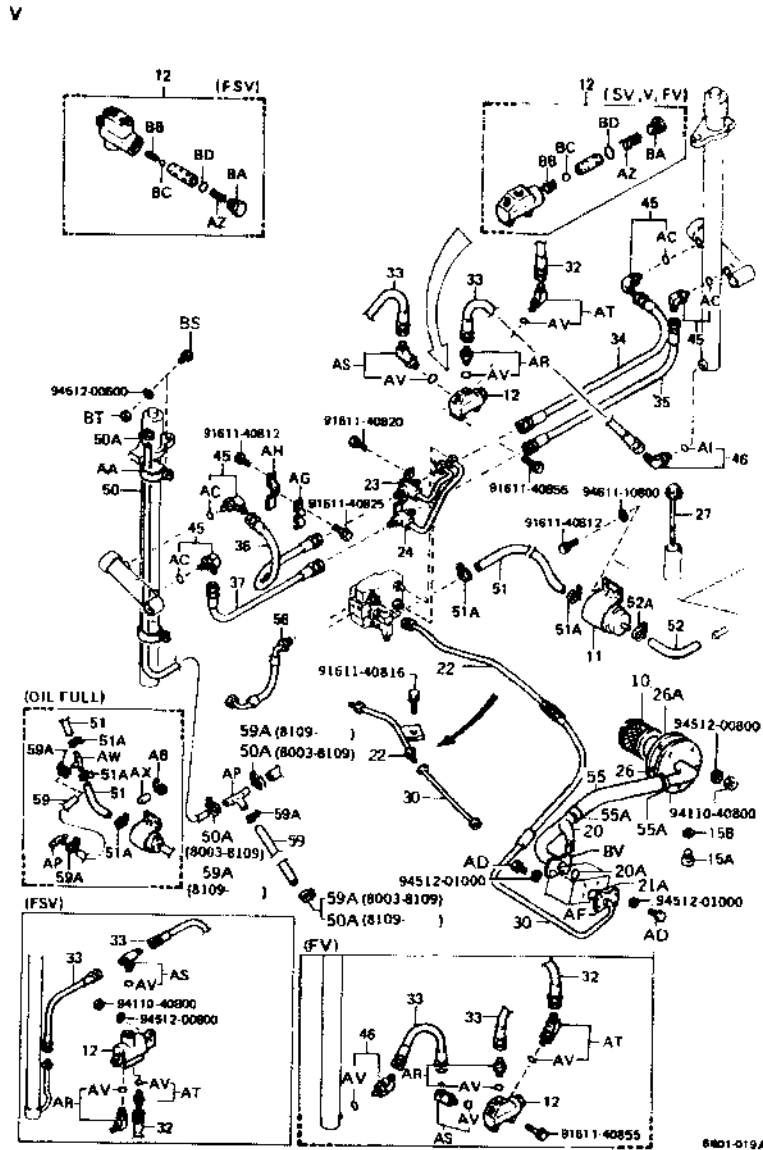

PART NAME CODE	PART NAME	QTY
6801-10	FILTER ASSY, SUCTION	1
6801-11	FILTER ASSY, RETURN	1
6801-12	VALVE ASSY, FLOW REGULATOR	1
6801-15A	PLUG (FOR OIL TANK DRAIN)	1
6801-15B	GASKET (FOR OIL TANK DRAIN PLUG)	1
6801-20	PIPE SUB-ASSY (PUMP INLET)	1
6801-20A	RING, O (FOR OIL PUMP INLET)	1
6801-21A	RING, O (FOR OIL PUMP OUTLET)	1
6801-22	PIPE SUB-ASSY (PUMP TO VALVE)	1
6801-23	PIPE SUB-ASSY (TILT CYLINDER FRONT)	1
6801-24	PIPE SUB-ASSY (TILT CYLINDER REAR)	1
6801-26	OUTLET SUB-ASSY, OIL TANK	1
6801-26A	PACKING, OIL TANK COVER	1
6801-27	CAP SUB-ASSY, OIL TANK	1
6801-30	HOSE, HIGH PRESSURE, NO.1 (PUMP TO VALVE)	1
6801-32	HOSE, HIGH PRESSURE, NO.1 (VALVE TO LIFT)	1
6801-33	HOSE, HIGH PRESSURE, NO.2 (VALVE TO LIFT)	2
6801-34	HOSE, HIGH PRESSURE, NO.1 (TILT FRONT)	1
6801-35	HOSE, HIGH PRESSURE, NO.1 (TILT REAR)	1
6801-36	HOSE, HIGH PRESSURE, NO.2 (TILT FRONT)	1
6801-37	HOSE, HIGH PRESSURE, NO.2 (TILT REAR)	1
6801-45	FITTING (FOR TILT CYLINDER)	2
6801-46	FITTING (FOR LIFT CYLINDER)	2
6801-50	HOSE, LOW PRESSURE, NO.1 (LIFT TO TANK)	2
6801-50A	CLAMP (FOR LIFT TO TANK NO.1 HOSE)	3
6801-51	HOSE, LOW PRESSURE, NO.1 (VALVE TO TANK)	1
6801-51A	CLAMP (FOR VALVE TO TANK NO.1 HOSE)	2
6801-52	HOSE, LOW PRESSURE, NO.2 (VALVE TO TANK)	1
6801-52A	CLAMP (FOR VALVE TO TANK NO.2 HOSE)	2
6801-55	HOSE, LOW PRESSURE (TANK TO PUMP)	1
6801-55A	CLAMP (FOR TANK TO PUMP HOSE)	2
6801-56	HOSE, LOW PRESSURE (STEERING TO VALVE)	1
6801-59	HOSE, LOW PRESSURE, NO.2 (LIFT TO TANK)	1
6801-59A	CLAMP (FOR LIFT TO TANK NO.2 HOSE)	3
6801-AA	BAND, LIFT CYLINDER OVERFLOW HOSE	4
6801-AB	CLAMP	1
6801-AC	RING, O	4
6801-AD	BOLT	8
6801-AF	FLANGE, SPLIT	1
6801-AG	CLAMP	1
6801-AH	BRACKET SUB-ASSY, TILT HOSE	1
6801-AI	RING, O	2
6801-AP	PIPE	1
6801-AS	FITTING	1
6801-AT	FITTING	1
6801-AV	RING, O	2
6801-AW	ELBOW SUB-ASSY, 3-WAY	1
6801-AX	CAP, OIL TANK OVERFLOW PIPE	1
6801-AZ	SPRING, COMPRESSION	1
6801-BA	PLUG	1
6801-BB	SPRING, COMPRESSION	1
6801-BC	BALL, STEEL	1
6801-BD	RING, O	1

6801

PART NAME CODE	PART NAME	QTY
6801-B5	BOLT -----	1
6801-BT	WASHER -----	1
6801-BV	FLANGE -----	2

(V) (11)

G210